

SPIDER a bit of information



Please read this before connecting power to the unit. There are important things about the power cable and cooling that must be done to allow for long life and reliable operation. As questions occur, contact us 715 398 3627
Thank you

David Hill

IMPORTANT

The Power Cable must not be connected or disconnected with the power on. You should wait 60 seconds before disconnecting the cable after powering off. Please tighten down the thumb screws to prevent the cable from coming disconnected.

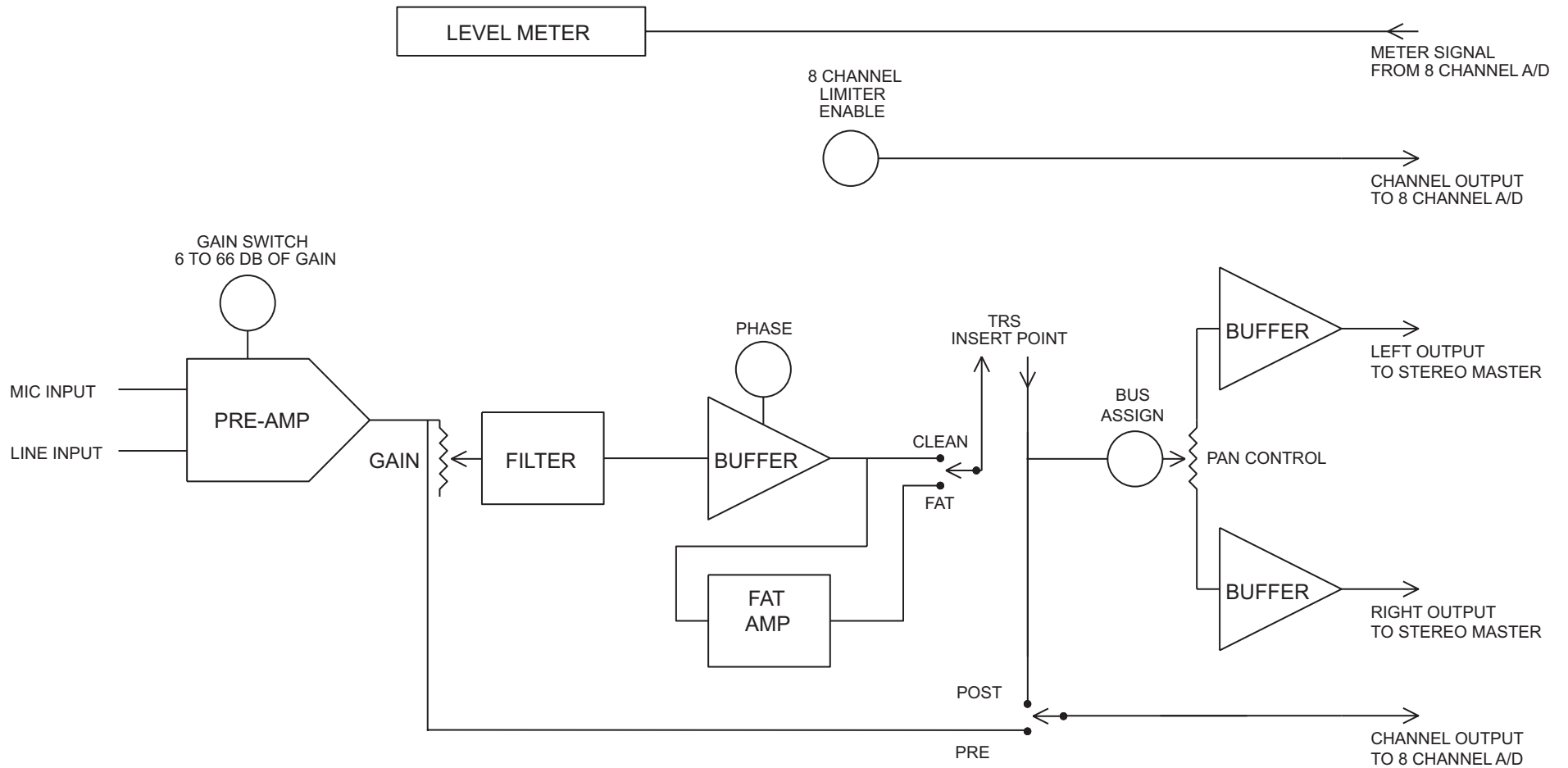

SPIDER INPUT MODULE

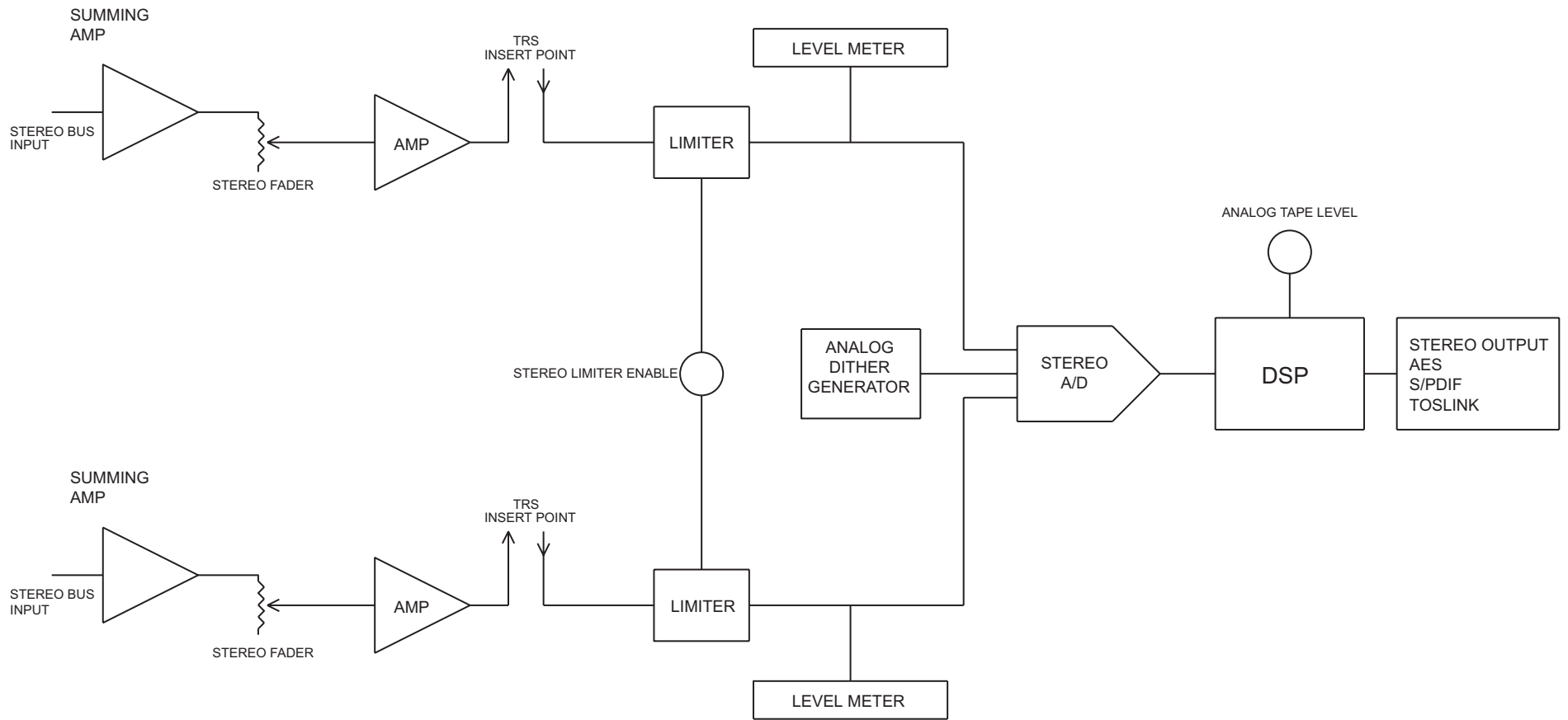

STEREO MASTER, A/D AND DSP

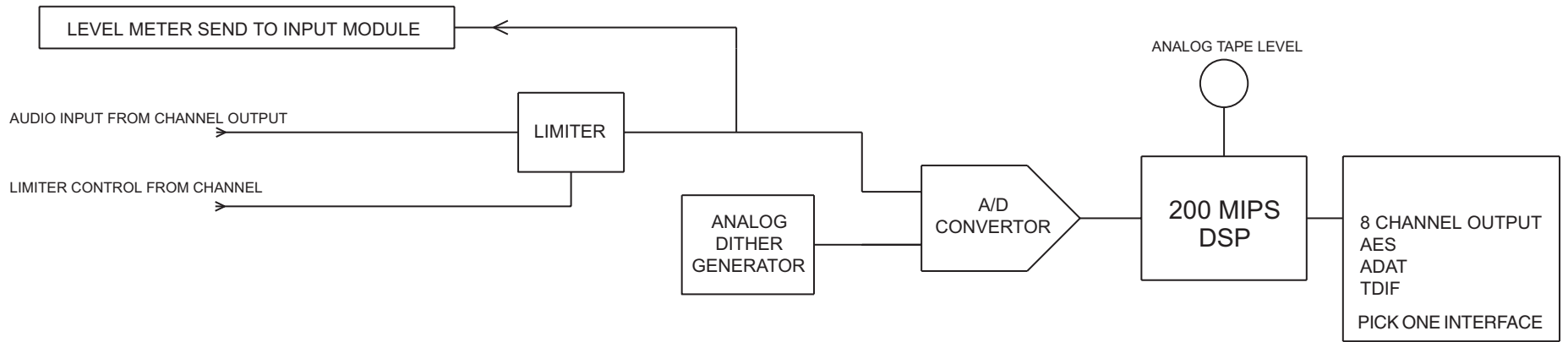

ONE OF EIGHT CHANNELS SHOWN

8 CHANNEL, A/D, DSP AND OUTPUT



The Power supply is an external 2 rack space box that is about 12 inches deep. Spider its self is 4 rack spaces and 6 inches deep. There is a 3-foot power cable to connect the 2 units.

Ventilation is a must if you block air flow you will have trouble. The total power is in the range of 100 watts of heat. It is best to have one rack space above and below each part of the system. If you mount them together leave a space between. Class A circuits run hot, but it turns out that the discrete class A analog circuits can handle heat much better that the digital components.

THE INPUT CHANNEL

The **GAIN SWITCH** is a 11-position step control which is adjustable from 6 to 66 dB of gain in 6 dB steps.

The **CHANNEL LEVEL CONTROL** is a variable control that controls the channel output level and the stereo bus mix level.

The **PAN OR PANORAMIC CONTROL** positions the channel output on the left - right stereo bus. This affects the stereo bus only.

The **PHANTOM POWER SWITCH** turns on or off the 48V power for phantom power and is active when the switch is pressed in

The **LINE/MIC SWITCH** selects between the line and mic inputs for the channel. When the switch is out, the mic input is selected and when it is pressed in, the line input is selected.

The **PHASE SWITCH** provides phase reversal for the channel. When the switch is out the channel operation is with normal phase. When the switch is pressed in the phase is reversed. This is referenced to pin 2 signal + on the mic input and tip signal + on the line input. The mic connector is an XLR where as the line input connector is a 1/4" TRS connector.

The **LOW CUT FILTER** is engaged when the switch is pushed in with a cutoff frequency of approx. 80 Hz. The filter is intended to be used in eliminating rumble, undesired low frequency content, and mud, while keeping the effect on the desired audio to a minimum. The slope reaches 12 dB pre octave. When the switch is out, the filter in not engaged and the low frequency response is to 3Hz.

When the **STEREO BUS ASSIGNMENT SWITCH** is pushed in the channel is assigned to the stereo bus. When the switch is out the channel is not assigned to the bus. The channel outputs are always assigned to the 8 channel outputs.

The **FAT AMPLIFIER** is enabled when the switch is active (pressed in). The fat amplifier is used to provide a different sound by inducing tube like distortions. This distortion content is almost all second harmonic with some third harmonic. The level of distortion is such that it reaches 6.5% at digital zero. It is 0.3% at +4dbm at the analog output which is 20 dB below digital zero.

The **LEVEL METER** is a 16-segment peak reading meter and is referenced to the A/D convertor. Analog head room is such that there is 6 db of analog head room above the level that is digital zero. This is to allow up to 6db of limiting before the A/D convertor. An “over” on the meter is a digital over, but not necessarily an indicator of analog clipping. (There is 6db of analog headroom above digital 0 with out the limiter engaged) There is also a clip indicator on each channel. This is a small red light in the upper left hand corner of the channel. This indicator shows an input or pre-amp overload. The level meter is an analog device that is feed from the A/D convertor input.

The **LIMITER** is for peak overload protection and is in front of the A/D convertor in the signal path. The level meter is post limiter. There is an indicator on the channel next to the limiter button that lights whenever limiter action is taking place. The limiter is enabled by pushing the LMT button down. The signal structure is such that the input channel can provide 6 dB more level that the A/D convertor needs. This head-room is for the operation of the peak limiter. The limiter will bring the level down thus protecting the A/D convertor from overload.

The **ANALOG INSERT POINT** is a 1/4" phone jack and is wired as tip send and ring return. This insert point is unbalanced and has a maximum signal level of +24 dbm. It can be used as an analog output

8 CHANNEL DIGITAL SECTION

The **SAMPLE RATE SELECTION SWITCH** allows the selection of 1 of 4 sample rates from 44.1K to 96K or the selection of a word clock source. The WC source is the same for both the stereo and 8 channel sections.

The **STEREO BUS** can be assigned to digital channels 7 and 8. This is to allow a mix to be recorded by a recorder on channels 7&8 of the 8 channel output. The assignment takes place by pushing the “bus 7&8” switch in. When this is done the normal connections from input channels 7 and 8 are disconnected. The limiter on the digital stereo module is still used to prevent digital overload on the bus signal.

The **DITHER CONTROL** provides dithering to different bit levels. This source is unique to CRANE SONG and is generated by analog means. The audio signal and the dither source are mixed together going into the A/D convertor. This is the best place to create dithering. The switch has many selections. There are 16 and 20 bit choices and some options for play and experimentation.

DSP ANALOG TAPE EMULATION is adjustable by channel. The tape emulation feature provides a means to have analog tape sound in Spider’s digital outputs. By selecting the channel, the LEDs around the process knob will light showing the current level of the process

By turning the process knob the control becomes active and allows the setting a new level. After a short pause the value is stored in internal memory and will be recalled the next time Spider is powered up. 8 channel digital outputs are AES and ADAT Optical. The tape emulation is the same as that in HEDD-192

THE STEREO OUTPUT SECTION

The **STEREO BUS MASTER FADER** is pre insert point. It affects the stereo digital output and the analog level that is available at the insert point. The Stereo level meter is referenced to the stereo A/D convertor. The red LED shows “overs” on the digital stereo bus. The insert point is in between the bus master control and the A/D convertor. This insert point also functions as an unbalanced analog output.

The **STEREO PEAK LIMITER** is for overload protection of the stereo A/D convertor. The limiter is designed as a stereo device, and phase relationships between the stereo channels do not affect limiter action.

A switch selectable **ANALOG DITHER** control with selections from 15 to 24 bits is provided. The sample rates are selectable from 44.1K to 96K. With the word clock input and output connections on the stereo master module. **DSP ANALOG TAPE EMULATION** is also provided on the stereo digital bus. The digital outputs for the stereo bus are AES, S/PDIF and tos link.

THE BACK PANELS

The input module back panels consist of an XLR connector for mic input pin 2 is signal (+), pin 3 signal (-) and pin 1 ground or shield. The line input is an 1/4" TRS jack with the tip signal + and the sleeve signal -. There are a set of jumpers on the top of the unit in each channel to change the sensitivity of the line input. The standard mode will allow up to a +18 dbm on the input with the 6db gain setting providing 6db of gain. In the padded mode there is a 20 db pad inserted on this input. The hi gain mode which is the standard mode will work in most cases and is recommended. The insert point is a 1/4" TRS with tip being the send and the sleeve being the return. If you want to leave this normal and also have the analog output available connect the tip and sleeve together and use this as your signal output.

The stereo master back has a left and right insert jack that works like the channel insert point. It also has an accessory connector to allow the analog sections of up to 3 spiders to be tied together and the power connector.

The stereo digital sections back panel has an XLR connector for AES output, a RCA connector for S/PDIF output, a optical connector for stereo optical output and 2 word clock connectors. The WC connectors are BNC connectors for WC in and WC out. This provides the WC connection for both the stereo and 8 channel outputs

The 8 channel digital output connectors depends on the type of interface. For AES outputs it has 4 XLR connectors, for ADAT it has 2 optical outputs.

Things to be aware of

When the stereo bus is assigned to digital outs 7 and 8. Be aware that the Stereo bus limiter still applies, but the DSP control is still adjusted by channel. This is because the DSP is post A/D convertor and we are reassigning the analog routing, not the digital routing.

The limiters are for peak control. If the limit light is on a lot they are being used more than intended

Boot up takes approx. 10 seconds this is to allow the A/D convertors to reach their highest accuracy level before use

When using WC. WC is common to both the stereo and 8 channel section. It may be necessary to set both sections the same depending on what one is trying to do

8 CHANNEL AES TO 192K AND ADAT TO 96K INTERFACE

STEREO BUS, AES, SPDIF AND OPTICAL TO 192K, WITH WC IN AND OUT INTERFACE

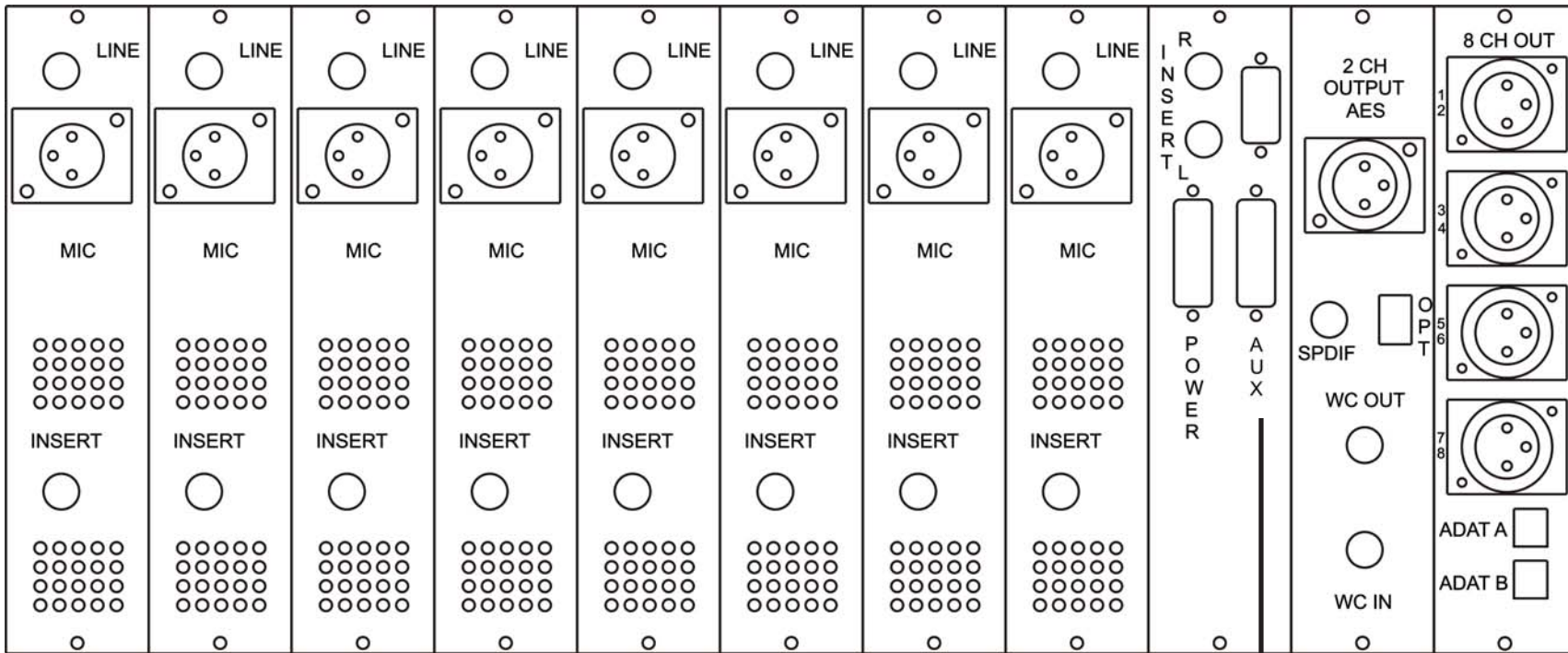

THE AUX CONNECTORS ALLOW ADDITIONAL ANALOG OUTPUTS AND ANALOG BUS INSERTS FOR TIEING 2 OR MORE UNITS TOGETHER. THESE ARE UNBALANCED CONNECTIONS

ALL INSERTS ARE TRS UNBALANCED.

THE LINE INPUTS ARE BALANCED.

THE INTERNAL ANALOG LEVEL IS TO +25 DBM

The red button, see next page when out the 8 channel A/D is feed from thr level control and the signal includes the filter and the fat amp
When in the pre amp directly feeds the A/D and the level control still works on the stereo bus.



STANDARD HIGH GAIN MODE

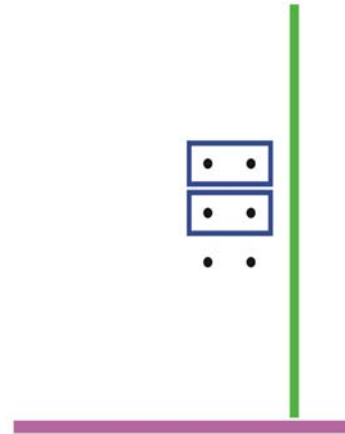

HI LEVEL INPUT MODE

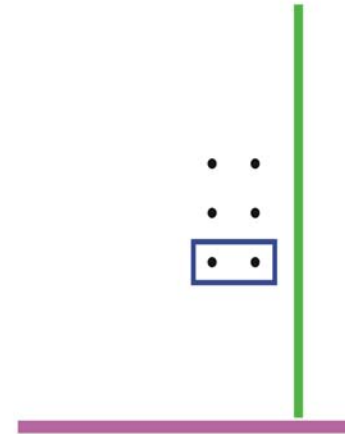

TOP AND FRONT VIEW OF INPUT MODULE

LINE INPUTS GAIN SELECT

YOU MUST REMOVE THE TOP COVER TO CHANGE THIS

CRANE SONG LTD.

2117 E. 5th Street
Superior, WI 54880 USA
tel. 715-398-3627
fax. 715-398-3279
E-mail: staff@cranesong.com

SPIDER 8 CHANNEL A MIC-PRE MIXER, A/D

REGISTRATION FORM

Please fill out this form and return it so we can send you updates and pertinent information as it becomes available.

Thank you.

NAME _____

STUDIO NAME _____

ADDRESS _____

CITY _____ STATE _____ ZIP _____

COUNTRY _____ PHONE _____

SERIAL # _____

DEALER _____

PURCHASE PRICE _____

EMAIL _____ WEBSITE _____