

Expanded Systems Guide

Version 6.4 for HD Systems on Windows or Macintosh

Digidesign

2001 Junipero Serra Boulevard
Daly City, CA 94014-3886 USA
tel: 650-731-6300
fax: 650-731-6399

Technical Support (USA)

650-731-6100
650-856-4275

Product Information (USA)

650-731-6102
800-333-2137

International Offices

Visit the Digidesign Web site
for contact information

Web Site

www.digidesign.com



digidesign

Copyright

This guide is copyrighted ©2004 by Digidesign, a division of Avid Technology, Inc. (hereafter "Digidesign"), with all rights reserved. Under copyright laws, this guide may not be duplicated in whole or in part without the written consent of Digidesign.

DIGIDESIGN, AVID and PRO TOOLS are trademarks or registered trademarks of Digidesign and/or Avid Technology, Inc. All other trademarks are the property of their respective owners.

Product features, specifications, system requirements, and availability are subject to change without notice.

PN 932013289-00 REV A 04/04

contents

Chapter 1. Introduction	1
Pro Tools Expanded Systems Without an Expansion Chassis	1
Pro Tools with an Expansion Chassis	2
Compatibility Information	2
Chapter 2. Expanded Pro Tools HD Systems	3
Adding Cards to Your System	4
Connecting Pro Tools HD Cards	6
Connecting Audio Interfaces	9
Chapter 3. Expansion Chassis	13
Magma 7-Slot Expansion Chassis	14
Digidesign and Magma 13-Slot Expansion Chassis	16
Digidesign and SBS 7-Slot Expansion Chassis	18

chapter 1

Introduction

You can expand your Pro Tools TDM system by adding Pro Tools TDM cards to your computer, either directly in the computer or using an expansion chassis. Expanding your Pro Tools system will provide an increased track count, add to the amount of possible plug-in and mixer processing, and let you connect additional audio interfaces.

 *For Pro Tools|24 MIX systems, refer to the previous version of this guide, published with Pro Tools 6.1 software. This guide is available online, with other Pro Tools 6.1 documentation, at the Digidesign Web site (www.digidesign.com).*

Pro Tools Expanded Systems Without an Expansion Chassis

Pro Tools|HD-series systems include an HD Core card, and can include one or more HD Accel or HD Process cards.

It is possible to install as many as five Pro Tools cards in some computers. If you require more PCI card slots than your computer has available, you can use an expansion chassis.

 *For PCI, hard drive, and other requirements for maximum track count, see the compatibility information on the Digidesign Web site (www.digidesign.com/compato).*

Pro Tools with an Expansion Chassis

You can use a Digidesign-qualified expansion chassis to increase the number of PCI card slots for your Pro Tools system. Expansion chassis will use only one PCI card slot in your computer and provide up to 13 additional PCI card slots in the chassis itself.

Expansion chassis consist of a chassis (providing additional PCI slots for your Digidesign cards), a host card (installed in your computer), a controller card (installed in the chassis), and an expansion chassis cable that connects the host card to the controller card. Some newer expansion chassis have a built-in controller card that does not need to be installed.

 *6-foot expansion chassis cables are not supported.*

13-slot expansion chassis support up to ten Digidesign cards (which can include a maximum of seven Pro Tools|HD-series cards).

7-slot chassis support up to seven Pro Tools|HD-series cards. Refer to the Digidesign Web site for the latest compatibility information (www.digidesign.com/compto).

 *See Chapter 3, “Expansion Chassis” for more information about card slot order and installing Pro Tools cards in an expansion chassis.*

Powering Up Expansion Chassis

Make sure to have the expansion chassis cable connected to both the expansion chassis and the computer before powering up. If the cable becomes disconnected from the computer while the system is powered on, shut down power to the computer and then the expansion chassis before reconnecting.

 *Before you connect your expansion chassis, or install cards in it, make sure to turn off both the chassis and your computer.*

When powering up, turn on the expansion chassis before the computer, and turn it off after powering down the computer.

Compatibility Information

For maximum track count with Pro Tools|HD Accel systems, 64-bit PCI is required. If using a CPU with mixed slot types, only the 64-bit slots should be used.

Digidesign can only assure compatibility and provide support for hardware and software it has tested and approved.

For a complete and current list of supported configurations of computers, expansion chassis, and hard drives, visit the Digidesign Web site (www.digidesign.com/compto).

chapter 2

Expanded Pro Tools|HD Systems

To ensure maximum track counts and trouble-free operations, it is important that PCI cards are installed in the appropriate slot locations.



For maximum track count with Pro Tools|HD Accel systems, 64-bit PCI is required. If using a CPU with mixed slot types, only the 64-bit slots should be used.

For a complete and current list of supported configurations of computers, expansion chassis, and hard drives, visit the Digidesign Web site (www.digidesign.com/com-pato).

Cards and Slot Order

When installing ‘cards’ in a computer or an expansion chassis, group cards according to type and install them in the following order, based on your Pro Tools system configuration:

Computer Configuration

- 1 HD Core card
- 2 HD Accel cards
- 3 HD Process cards
- 4 SCSI accelerator cards

Computer Configuration with Expansion Chassis

- 1 Expansion chassis host card
- 2 SCSI accelerator card

Expansion Chassis Configuration

- 1 HD Core card
- 2 HD Accel cards
- 3 HD Process cards

Sample Rate and Multiple Cards

Pro Tools|HD supports sample rates of 44.1 kHz, 48 kHz, 88.2 kHz, 96 kHz, 176.4 kHz, and 192 kHz. However, due to the processing load required for 176.4 kHz and 192 kHz sessions, a maximum of four HD-series cards can be used at these higher sample rates.

If your system includes more than four Pro Tools|HD-series cards, the fifth card (and any additional cards) will automatically be taken offline when Pro Tools sessions are set to 176.4 kHz or 192 kHz. You do not need to remove any cards or cables; Pro Tools automatically deactivates the additional cards, and reactivates them when the sample rate is switched to 96 kHz or lower.

Any audio interfaces connected to inactive cards will go offline.

Adding Cards to Your System

The maximum number of HD-series cards supported in a single system is seven. However, there may be further restrictions depending on sample rate, your operating system, and the specific model of your expansion chassis. For the most current information, visit the Digidesign Web site (www.digidesign.com/compato).

To install Pro Tools cards:

- 1 Turn off your computer, expansion chassis, and any peripherals. Leave your computer's power cable plugged in so the computer is grounded.
- 2 Wait 5–10 minutes to allow the computer's internal components to cool down to avoid burning yourself.
- 3 Disconnect all cables attached to the computer (such as hard drives, displays, USB and FireWire connections) except for the power cable.
- 4 To prevent damaging sensitive electronics, discharge any static electricity that may be on your clothes or body by touching a grounded metal surface, such as the metal PCI access covers on the back of the computer.
- 5 Disconnect the power cord from the computer.
- 6 Open the computer case or expansion chassis.
- 7 Remove the metal access port cover behind the expansion slot you want to use by removing the screw and sliding the cover out from the access port. Keep the screws in a safe place.
- 8 Install the HD Core card in the lowest numbered slot.

On a Windows PC (such as an IBM M Pro or a Compaq Evo 8000), this will be the slot furthest from the graphics card.

 Refer to your computer's documentation to verify slot order.

On a Macintosh, this will be the slot closest to the graphics card, as shown in the following examples:

Power Mac G5 The Power Mac G5 has three PCI slots (named PCI slot 2, 3, and 4). PCI slot numbers increase from *bottom to top* as you face the open computer case from the front. Install the HD Core card into PCI slot 2.

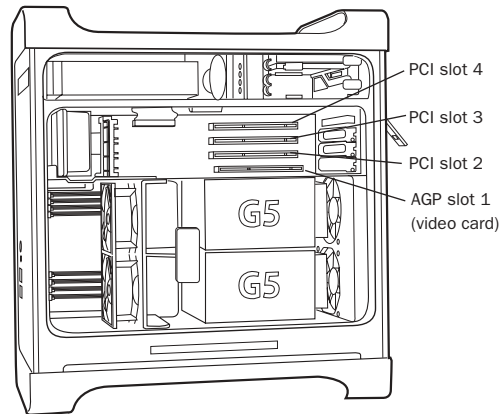
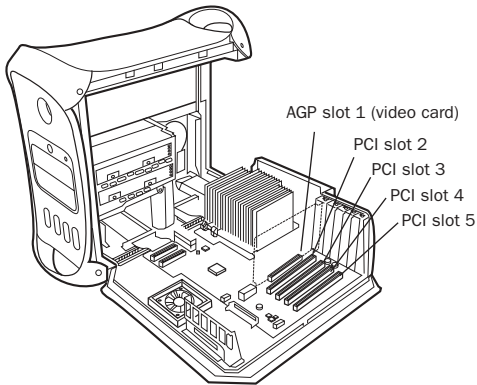

Figure 1. Power Mac G5

Power Macintosh “Mirrored Door” G4 The Power Macintosh “Mirrored Door” G4 has reflective drive bay doors and four holes across the front. Its PCI slot numbers increase from *left to right* as you face the open computer case from the front.

Note that the PCI slot numbering in the newer “Mirrored Door” G4 computer runs in the opposite direction of previous G4 models.

⚠ Be very careful when opening or closing the case of a “Mirrored Door” G4 computer. Any PCI cards installed in the higher-numbered slots may be damaged if they touch the top of the computer case.



Power Macintosh “Mirrored Door” Dual Processor G4

Power Macintosh “QuickSilver” G4 The Power Macintosh “QuickSilver” and earlier G4 models have a single speaker grille or hole on the front. Their PCI slot numbers increase from *right to left* as you face the open computer case from the front.

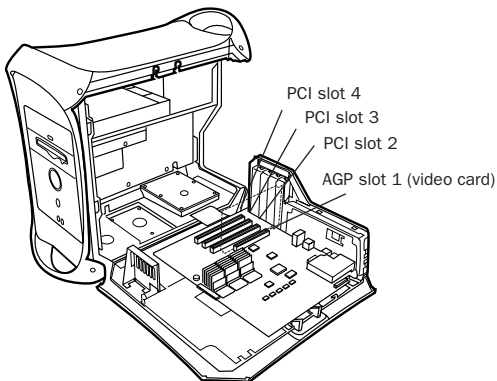

Power Macintosh “QuickSilver” Dual Processor G4

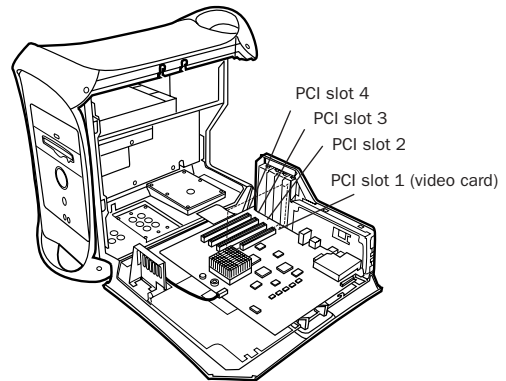

Power Macintosh Single Processor G4

9 Install HD Accel cards (if any) in the next slots.

⚠ Group similar cards together (for example, put all HD Accel cards next to each other).

10 Install HD Process cards (if any) in remaining slots.

⚠ Make sure the first card is a Core card. HD Accel and HD Process cards cannot occupy the lowest-numbered slot.

11 Connect all Pro Tools|HD cards using Digi-design TDM FlexCables (see “Digidesign TDM FlexCable” on page 6).

12 If installing a SCSI HBA card, install it in the highest numbered remaining slot.

⚠ Run DigiTest after making any changes to your hardware setup (such as adding or removing cards, audio interfaces, sync cables, and so on) to verify that your system is functioning properly. For DigiTest information, refer to your Getting Started Guide.

13 Secure each card in place with the slot access port screws you removed earlier.

Connecting Pro Tools|HD Cards

Digidesign TDM FlexCable

Digidesign TDM FlexCable cables connect one Pro Tools|HD card to another. You will need an additional TDM FlexCable for each additional card.

Each HD card has two ports along the top of the card, labelled Port A and Port B. The FlexCable has two connectors, also labeled Port A and Port B, to ensure proper connection.

When installing multiple HD cards, data communication across HD cards is achieved by using the TDM FlexCable to connect Port B of the first card to Port A of the next card.

To connect HD cards with the TDM FlexCable on a Windows PC or Power Macintosh “Mirrored Door” G4

1 Shape the FlexCable before installing it on your HD cards by grasping the cable with both hands and moving the Port B portion of the cable straight towards you and inwards, as shown below. Do not bend the cable more than you need to, as you may damage the traces in the cable.

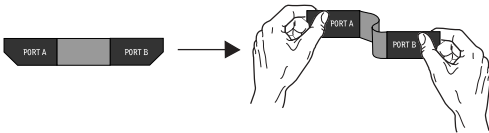

Preparing TDM FlexCable for installation



The first FlexCable always go from Port B on the HD card to Port A on the Accel or Process card.

2 Slide the FlexCable into the notch of the *first* card, so that the Port B connector of the FlexCable can be aligned with Port B of the first card; and the Port A connector of the FlexCable can be aligned with Port A of the second card, as shown below.

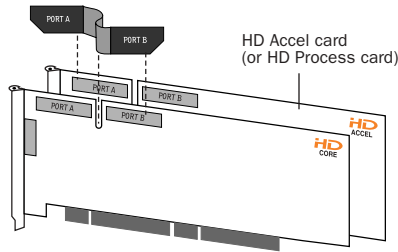

Inserting TDM FlexCable

3 Connect the Port A connector of the FlexCable to Port A on the second card. Push down gently but firmly until the cable is fully connected to the card. Attach the other end of the FlexCable (labeled Port B) to Port B on the first card.

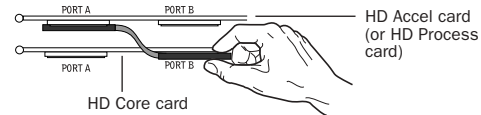

Top view of two HD cards connected with TDM FlexCable

4 Verify the connection, as shown below (orientation may be different depending on your type of CPU or chassis).

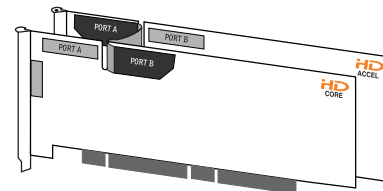

Side view of two HD cards connected with TDM FlexCable

5 For systems with more than two cards, connect each additional card to its preceding card. Use FlexCables to connect card pairs together, as described above, until all cards are connected. (Each HD Accel card is packaged with a FlexCable.)

6 Close the computer case.

7 Proceed to “Connecting Audio Interfaces” on page 9.

To connect HD cards with the TDM FlexCable on the Power Mac G5:

1 Shape the FlexCable before installing it on your HD cards by grasping the cable with both hands with its printed side facing you and moving the Port B portion of the cable away from you and outwards, as shown below. Do not bend the cable more than you need to, as you may damage the traces in the cable.

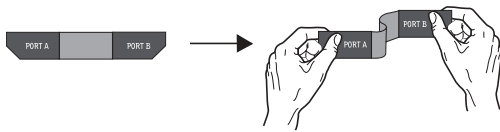

Preparing TDM FlexCable for installation

2 Turn the cable on its side, so that the connectors are facing downwards, and Port A is the higher side.

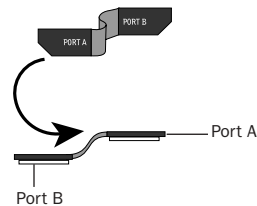

Orienting the FlexCable

3 Slide the FlexCable into the notch of the *second* card, so that the Port B connector of the FlexCable can be aligned with Port B of the first card; and the Port A connector of the FlexCable can be aligned with Port A of the second card as shown below.

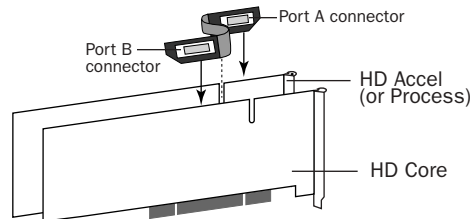

Inserting TDM FlexCable

4 Connect the Port A connector of the FlexCable to Port A on the second card. Push down gently but firmly until the cable is fully connected to the card. Attach the other end of the FlexCable (labeled Port B) to Port B on the first card.

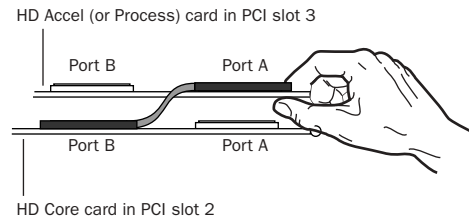

Top view of TDM FlexCable connections for two HD cards

5 Verify the connection. Make sure the FlexCable ports seat flat against the sockets on the HD cards, and are firmly attached.

6 For systems with more than two cards, connect each additional card to its preceding card. Use FlexCables to connect card pairs together, as described above, until all cards are connected. Each HD Accel or HD Process card is packaged with a FlexCable.

7 Close the computer case.

8 Proceed to “Connecting Audio Interfaces” on page 9.

To connect HD cards with the TDM FlexCable on Power Macintosh “QuickSilver” and earlier G4 computers:

1 Shape the FlexCable before installing it on your HD cards by grasping the cable with both hands and moving the Port A portion of the cable straight towards you and inwards, as shown below. Do not bend the cable more than you need to, as you may damage the traces in the cable.

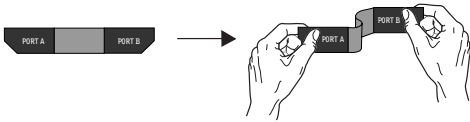

Preparing TDM FlexCable for installation

2 Slide the FlexCable into the notch of the second card, so that the Port B connector of the FlexCable can be aligned with Port B of the first card; and the Port A connector of the FlexCable can be aligned with Port A of the second card, as shown below.

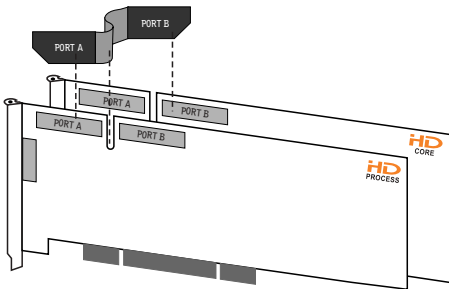

Inserting TDM FlexCable

3 Connect the Port A connector of the FlexCable to Port A on the second card. Push down gently but firmly until the cable is fully connected to the card. Next, attach the other end of the FlexCable (labeled Port B) to Port B on the first card.

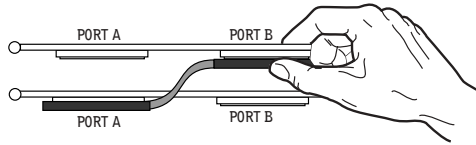

Top view of two HD cards connected with TDM FlexCable

4 Verify the connection, as shown below.

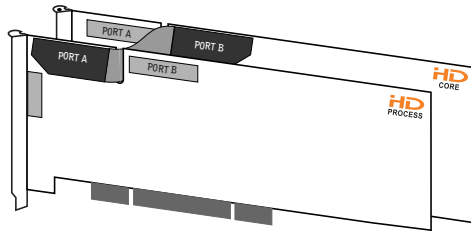

Side view of two HD cards connected with TDM FlexCable

5 For systems with more than two cards, connect each additional card to its preceding card. Use FlexCables to connect card pairs together, as described above, until all cards are connected. (Each HD Accel card is packaged with a FlexCable.)

6 Close the computer case.

7 Proceed to “Connecting Audio Interfaces” on page 9.

 For more information about installing Pro Tools|HD-series cards see the “Getting Started with HD Guide.”

Connecting Audio Interfaces

All HD-series audio interfaces require DigiLink connections. When using multiple interfaces, you must also connect Loop Sync between all HD-series audio interfaces. When using multiple Legacy interfaces (MIX-series I/O such as the 888|24 I/O and 882|20 I/O) you must connect Slave Clock to all MIX-series audio interfaces.

Recommended Ordering of Interfaces

If your setup includes different types of audio interfaces, install them in the following order:

192 I/O or 192 Digital I/O Use as the *primary* audio interface. These interfaces provide the highest fidelity clock source for your system.

▲ *If you have at least one 192 I/O or 192 Digital I/O in your Pro Tools system, it should be the primary audio interface and Loop Sync master.*

96 I/O Use as the primary interface (if a 192 I/O or 192 Digital I/O is not installed), or as an expansion interface connected to the Expansion port of the primary interface.

96i I/O Use as the primary interface if no other HD-series interfaces are installed, or as an expansion interface connected to the Expansion port of another HD-series interface.

Legacy Peripherals See “Using Legacy Audio Interfaces” on page 12.

DigiLink

The DigiLink cable connects HD cards and audio interfaces. A single Digi-Link connector carries up to 32 channels of bidirectional audio information. These 32 channels are broken up into 2 groups of 16 channels: Group A = Channels 1–16, Group B = Channels 17–32.

The maximum number of DigiLink cables supported on a single system is eight. This allows up to 128 channels of I/O with eight HD-series audio interfaces: four connected directly to an HD card and the remaining four connected to the expansion ports of the first four.

- ◆ Use the 12-foot DigiLink cable included with each Pro Tools|HD card to connect the card to a Digidesign audio interface. The primary audio interface, which functions as the Loop Sync master for other interfaces in the system, must be connected to the HD Core card. You can purchase optional DigiLink cables of differing lengths (25-foot, 50-foot, and 100-foot), depending on the needs of your studio configuration.
- ◆ Use the 18-inch DigiLink cable, included with each HD-series audio interface, when connecting a secondary HD-series audio interface to the Expansion port of another HD-series audio interface.

To make DigiLink connections to Digidesign audio interfaces:

- 1** Connect the primary audio interface to the HD Core card with the provided 12-foot DigiLink cable.
- 2** Connect a secondary HD-series audio interface to the Expansion port on the primary audio interface using the 18-inch DigiLink cable (included with the audio interface). See Figure 2 on page 11.
 - or –
 - Connect a secondary HD-series interface to the DigiLink on the next card (HD Accel or HD Process).
- 3** Connect additional HD-series audio interfaces to subsequent Pro Tools|HD audio interfaces or cards. See Figure 3 on page 11.
- 4** If connecting a Digidesign Legacy audio interface (such as the 888|24 I/O), refer to “Using Legacy Audio Interfaces” on page 12.

Loop Sync**To connect Loop Sync:**

- 1** Connect the Loop Sync Out of the primary interface to the Loop Sync In of the second interface with the provided Loop Sync cables.
- 2** Connect the Loop Sync Out of the second interface to the Loop Sync In of the next interface and so forth.
- 3** Connect the Loop Sync Out of the last interface to the Loop Sync In of the primary interface.

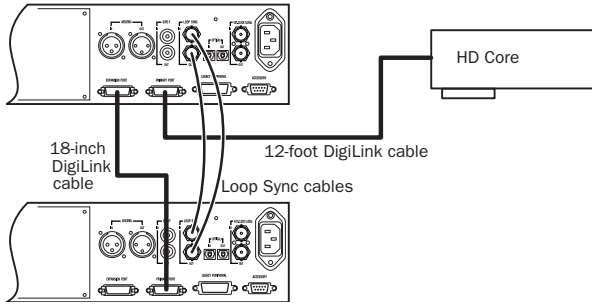

Figure 2. Two 96 I/Os, 32-channel

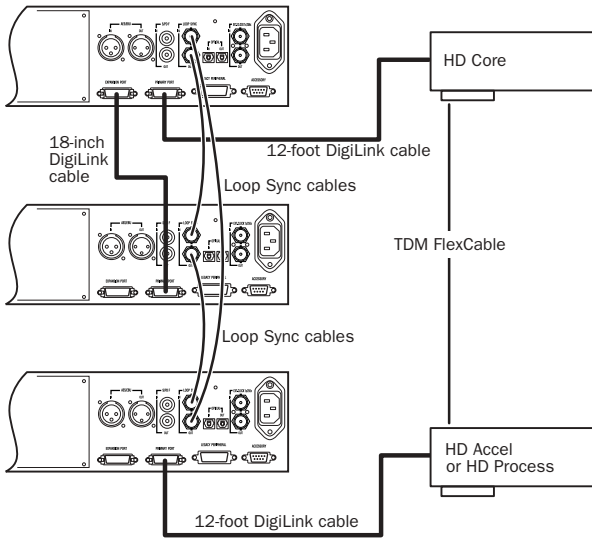

Figure 3. Three 96 I/Os, 48-channel

Using Legacy Audio Interfaces

Each 192 I/O, 192 Digital I/O, and 96 I/O can support 16 channels of audio to and from Digidesign legacy audio interfaces, or Legacy I/Os. These include the 888|24 I/O, 882|20 I/O, 1622 I/O, 24-bit ADAT Bridge I/O, and the original ADAT Bridge I/O. The 888 I/O and 882 I/O interfaces are not supported with Pro Tools|HD. (The 96i I/O does not provide a Legacy port.)

The Legacy Peripheral port functions like the Expansion port.

⚠ *The Legacy port and the Expansion port are mutually exclusive. They both use Group B: Channels 17–32. Choose between the Legacy port and the Expansion port in the Pro Tools Hardware Setup dialog.*

A single Legacy peripheral can be connected to the Legacy Peripheral port using any Pro Tools MIX peripheral cable. Two Legacy interfaces can be connected to a single Legacy Peripheral port using a “Y” cable (16-channel Peripheral Cable Adapter).

The maximum number of Legacy peripherals that can be connected to an HD system is eight; requiring four HD-series audio interfaces and four 16-channel Peripheral Cable Adapters.

⚠ *The Legacy port is not available in Pro Tools sessions at sample rates greater than 48 kHz.*

To connect Digidesign Legacy audio interfaces:

- 1 Connect one end of a Pro Tools|24 MIX peripheral cable to the Legacy port on a 192 I/O, 192 Digital I/O, or 96 I/O.
- 2 Connect the other end of the cable to your MIX compatible audio interface.

3 Connect the External Clock Out of the primary interface to the Slave Clock In of the Legacy audio interface using a BNC cable.

4 If connecting two Legacy peripherals, connect the Slave Clock Out of the first Legacy peripheral to the Slave Clock In of the second Legacy peripheral.

⚠ *Do not connect the Slave Clock Out of the last Legacy peripheral to the clock input on any HD-series interface.*

⚠ *If using an 888|24 I/O, do not power on the 888|24 until you are ready to declare it in the Hardware Setup dialog, after launching Pro Tools. See the “Getting Started with HD Guide” for more information.*

Identifying Audio Interfaces

If you have multiple audio interfaces of the same type connected to your system, you can confirm the identity of each interface. This ensures that you choose the appropriate interface in the Peripherals list when you define its inputs and outputs in the Hardware Setup dialog.

To identify audio interfaces in your system:

- 1 Choose Setups > Hardware Setup.
- 2 From the Peripherals list, select an audio interface connected to your system.
- 3 Make sure the Main page tab is chosen.
- 4 Select the Identify option, located in the lower left corner of the Hardware Setup dialog. This illuminates all the LEDs on the front panel of the selected audio interface.
- 5 Make a note of which interface in your studio setup corresponds to the identified interface.
- 6 Repeat the above steps for each additional audio interface in your setup.

chapter 3

Expansion Chassis

This chapter provides information for configuring Digidesign-qualified expansion chassis.



For a complete and current list of supported configurations of computers, expansion chassis, and hard drives for maximum voices with Pro Tools systems, visit the Digidesign Web site (www.digidesign.com/compato).



Not all chassis are supported on all Pro Tools systems.

Consult your Digidesign dealer or the Digidesign Web site (www.digidesign.com/compato) before purchasing an expansion chassis for your Pro Tools system.

Magma 7-Slot Expansion Chassis

Slot Layout for Magma 7-Slot Expansion Chassis

Magma models P7R-D1 and P7RQ-D1 have slots that are numbered sequentially, right-to-left from the front (4–10).

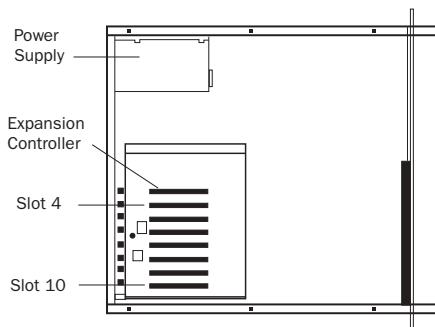

Slot numbering for Magma model PCI-7R

The 64-bit, 33 MHz Magma 7-Slot Expansion Chassis model PCI7R464 has slots that are numbered sequentially, right-to-left from the front (1–7).

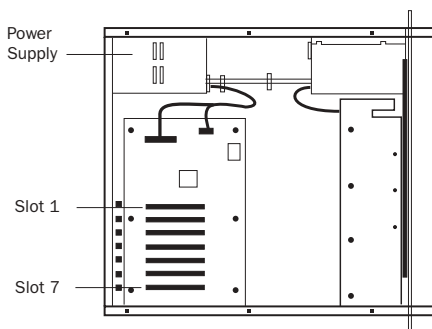

Slot numbering for Magma model PCI7R464

Configuring the Magma 7-Slot Expansion Chassis

Connecting the Expansion Chassis

Install the chassis host card:

1 Turn off the expansion chassis, your computer, and any peripherals. Leave your computer's power cable plugged in so the computer is grounded.

2 Open the computer case. For additional details on installing a card in your computer, refer to its documentation.

⚠ Before removing cards from their antistatic bags or handling any card, discharge any static electricity that may be on your clothes or body by touching a grounded metal surface (such as the power supply case inside your computer).

3 Install the Magma Host Card in the lowest numbered slot in your computer. On a Windows PC (such as an HP Workstation xw8000 or Dell Precision Workstation 650), this will be the slot furthest from the graphics card. On a Macintosh, this will be the slot closest to the graphics card.

 Refer to your computer's documentation to verify slot order.

4 Attach a 2- or 4-foot expansion chassis cable to the host card. If necessary, refer to the Magma guide for specific instructions.

⚠ 6-foot expansion chassis cables are not supported.

5 If using a SCSI HBA, install it in the highest numbered remaining slot in your computer.

Install the chassis controller card:

- 1 Install the Magma Controller card in the Expansion Slot of the expansion chassis.
- 2 Attach the other end of the expansion chassis cable to the controller card. If necessary, refer to the Magma guide for specific instructions.

Installing the Digidesign Cards

Install the Digidesign audio cards:

- 1 Install the Pro Tools Core card in the first slot (numbered slot 4 in Magma models P7R-D1 and P7RQ-D1) of the expansion chassis.
- 2 Install the remaining cards in successive PCI card slots in the chassis, according to your Pro Tools system:
 - Pro Tools|HD
 - HD Accel
 - HD Process
- 3 Connect all Pro Tools cards with TDM FlexCables. See “Connecting Pro Tools|HD Cards” on page 6.

⚠ *HD-series cards and Pro Tools|24 MIX-series cards are not compatible, and cannot be used in the same computer. HD cards can only be used in Pro Tools|HD-series systems, and MIX cards can only be used in Pro Tools|24 MIX-series systems.*

Example 1, Magma 7-Slot

Chassis cards with multiple audio interfaces:

Slot	Card
Exp. Slot	Chassis Controller Card
Slot 1	HD Core (Interface #1 and #2)
Slot 2	HD Accel (interface #3 and #4)
Slot 3	HD Accel (Interface #5 and #6)
Slot 4	HD Accel (Interface #7 and #8)
Slot 5	HD Process
Slot 6	HD Process
Slot 7	HD Process

Connecting Audio Interfaces

See “Connecting Audio Interfaces” on page 9.

Digidesign and Magma 13-Slot Expansion Chassis

(Macintosh Only)

Digidesign 13-Slot Expansion Chassis

Digidesign Expansion Chassis with serial numbers NB06000C1 or higher are identical to the Magma model PCI-13R. For compatibility and configuration details, refer to the information that pertains to that model on the Digidesign Web site (www.digidesign.com).

 *The Digidesign Pro Tools Expansion Chassis 13-slot is supported on Mac OS X.*

Slot Layout for Digidesign 13-Slot Expansion Chassis

The Digidesign 13-Slot Expansion Chassis has slots that are numbered sequentially, right-to-left from the front, in two banks (4–9 and 4–10).

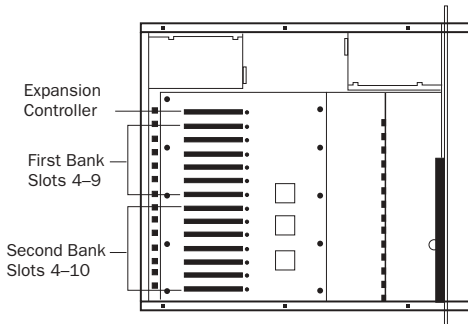

Slot numbering for the Digidesign 13-slot Expansion Chassis

Configuring the Digidesign 13-Slot Expansion Chassis

Connecting the Expansion Chassis

Install the chassis host card:

- 1 Turn off the expansion chassis, your computer, and any peripherals. Leave your computer's power cable plugged in so the computer is grounded.
- 2 Open the computer case. For additional details on installing a card in your computer, refer to its documentation.

 *Before removing cards from their antistatic bags or handling any card, discharge any static electricity that may be on your clothes or body by touching a grounded metal surface (such as the power supply case inside your computer).*

- 3 Install the Digidesign Host Card in the lowest numbered slot in your computer. This will be the slot closest to the graphics card.

 *Refer to your computer's documentation to verify slot order.*

- 4 Attach a 2- or 4-foot expansion chassis cable to the host card.

 *If using Digidesign 13-Slot Expansion Chassis, make sure you attach the chassis cable to the host card and not your SCSI HBA. Both cards have a 68-pin VHDCI connector.*

 *6-foot expansion chassis cables are not supported.*

- 5 If using a SCSI HBA, install it in the highest numbered remaining slot in your computer.

Install the chassis controller card:

- 1 Install the Digidesign Controller card in the Expansion Slot of the expansion chassis. For Magma model PCI-13R, this is the slot nearest the power supply.
- 2 Attach the other end of the expansion chassis cable to the controller card.

Installing the Digidesign Cards

Install the Digidesign audio cards:

- 1 Install the Pro Tools Core card in slot 4 (the first available slot) of the expansion chassis.
- 2 Install the remaining cards in successive PCI card slots in the chassis, according to your Pro Tools system:
 - Pro Tools|HD
 - HD Accel
 - HD Process
- 3 Connect all Pro Tools cards with TDM FlexCables. See “Connecting Pro Tools|HD Cards” on page 6.

⚠ *HD-series cards and Pro Tools|24 MIX-series cards are not compatible, and cannot be used in the same computer. HD cards can only be used in Pro Tools|HD-series systems, and MIX cards can only be used in Pro Tools|24 MIX-series systems.*

Example 2, Digidesign 13-Slot

Chassis cards with multiple audio interfaces:

Slot	Card
Exp. Slot	Chassis Controller Card
Bank 1/Slot 4	HD Core (Interface #1 and #2)
Bank 1/Slot 5	HD Accel (interface #3 and #4)
Bank 1/Slot 6	HD Accel (Interface #5 and #6)
Bank 1/Slot 7	HD Accel (Interface #7 and #8)
Bank 1/Slot 8	HD Accel or HD Process (Interface #9)
Bank 1/Slot 9	HD Accel or HD Process
Bank 2/Slot 4	HD Accel or HD Process
Bank 2/Slot 5	(empty)
Bank 2/Slot 6	(empty)
Bank 2/Slot 7	(empty)
Bank 2/Slot 8	Available for non-bus master card
Bank 2/Slot 9	Available for non-bus master card
Bank 2/Slot 10	Available for non-bus master card

Connecting Audio Interfaces

See “Connecting Audio Interfaces” on page 9.

Digidesign and SBS 7-Slot Expansion Chassis

(Macintosh Only)

Digidesign 7-Slot Expansion Chassis

The Digidesign 7-Slot Expansion Chassis is identical to the SBS model DD007-R. For compatibility and configuration details, refer to the information that pertains to that model.

 *The Digidesign Expansion Chassis 7-slot is supported on Mac OS X.*

 *SBS Technologies was previously called "Bit 3."*

Slot Layout for Digidesign 7-Slot Expansion Chassis

The Digidesign 7-Slot Expansion Chassis has slots that are numbered sequentially (1–7), left-to-right, from the front.

The Digidesign 7-Slot Expansion Chassis does not have a Backplane Controller slot. It instead has a built-in chassis controller with a connector on the back of the expansion chassis.

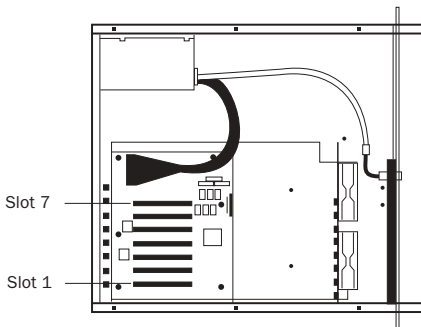

Slot numbering for Digidesign 7-Slot Expansion Chassis

Configuring the Digidesign 7-Slot Expansion Chassis

Connecting the Expansion Chassis

Install the chassis host card:

1 Turn off the expansion chassis, your computer, and any peripherals. Leave your computer's power cable plugged in so the computer is grounded.

2 Open the computer case. For additional details on installing a card in your computer, refer to its documentation.

 *Before removing cards from their antistatic bags or handling any card, discharge any static electricity that may be on your clothes or body by touching a grounded metal surface (such as the power supply case inside your computer).*

3 Install the Digidesign Host Card in the lowest numbered slot in your computer. This will be the slot closest to the graphics card.

 *Refer to your computer's documentation to verify slot order.*

4 Attach a 2- or 4-foot expansion chassis cable to the host card.

 *6-foot expansion chassis cables are not supported.*

5 If using a SCSI HBA, install it in the highest numbered remaining slot in your computer.

Install the chassis controller card:

1 Attach the chassis cable to the connector on the back of the expansion chassis.

2 Attach the other end of the expansion chassis cable to the controller card.

Installing the Digidesign Cards

Install the Digidesign audio cards:

1 Install the Pro Tools Core card (clock master with primary audio interface) in slot 1 of the expansion chassis.

2 Install the remaining cards in successive PCI card slots in the chassis, according to your Pro Tools system:

- Pro Tools|HD
 - HD Accel
 - HD Process

3 Connect all Pro Tools cards with TDM FlexCables. See “Connecting Pro Tools|HD Cards” on page 6.

⚠ *HD-series cards and Pro Tools|24 MIX-series cards are not compatible, and cannot be used in the same computer. HD cards can only be used in Pro Tools|HD-series systems, and MIX cards can only be used in Pro Tools|24 MIX-series systems.*

Example 3, Digidesign 7-Slot

Chassis cards with multiple audio interfaces:

Slot	Card
Slot 1	HD Core (Interface #1 and #2)
Slot 2	HD Accel or HD Process (interface #3 and #4)
Slot 3	HD Accel or HD Process (interface #5 and #6)
Slot 4	HD Accel or HD Process (interface #7 and #8)
Slot 5	HD Accel or HD Process
Slot 6	HD Accel or HD Process
Slot 7	HD Accel or HD Process

Connecting Audio Interfaces

See “Connecting Audio Interfaces” on page 9.