

Getting Started with Pro Tools|HD

Version 6.4 for HD Systems on Windows or Macintosh

Digidesign

2001 Junipero Serra Boulevard
Daly City, CA 94014-3886 USA
tel: 650-731-6300
fax: 650-731-6399

Technical Support (USA)

tel: 650-731-6100
fax: 650-731-6384

Product Information (USA)

tel: 650-731-6102
tel: 800-333-2137

International Offices

Visit the Digidesign Web site
for contact information

Web Site

www.digidesign.com



digidesign

Copyright

This guide is copyrighted ©2004 by Digidesign, a division of Avid Technology, Inc. (hereafter "Digidesign"), with all rights reserved. Under copyright laws, this guide may not be duplicated in whole or in part without the written consent of Digidesign.

DIGIDESIGN, AVID and PRO TOOLS are trademarks or registered trademarks of Digidesign and/or Avid Technology, Inc. All other trademarks are the property of their respective owners.

Product features, specifications, system requirements, and availability are subject to change without notice.

PN 910613320-00 REV A 04/04

contents

Chapter 1. Welcome to Pro Tools HD	1
Pro Tools TDM Systems	1
System Requirements	4
Digidesign Registration	7
About the Pro Tools Guides	7
About www.digidesign.com	8
Chapter 2. Windows Configuration	9
Installing Windows XP	9
Configuring Your Computer	10
Windows System Settings	13
Pro Tools Hardware Overview	15
Installing Pro Tools Hardware	17
Installing Pro Tools Software	23
Installing Optional Software	24
Installing the Demo Session	25
Configuring MIDI	26
Checking Your HD System	26
Launching Pro Tools	29
Configuring Pro Tools	29

Chapter 3. Macintosh Configuration	41
Pro Tools Hardware Overview	41
Installing Pro Tools Hardware	43
Apple System Settings	52
Installing Pro Tools Software	52
Installing the Demo Session	53
Checking Your HD System	54
Launching Pro Tools	56
Configuring Pro Tools	57
Chapter 4. Connecting Your Studio	69
Setting Up Your Studio	69
Example Studio Setup with a Mixing Console	70
Example Studio Setup without a Mixing Console	71
Connecting Equipment with Digital Audio Ins and Outs	72
Connecting Effects Units	73
Connecting MIDI Devices	74
Connecting SMPTE Synchronization Devices	74
Chapter 5. Working with Pro Tools	75
Session Basics	75
Transport Controls	80
Tracks	81
Regions Lists	84
Navigating in a Session	85
Importing Audio	87
Basic Recording	88
Editing	93
Mixing	96
Plug-Ins	99
Mix Automation	100
Final Mixdown	101

Appendix A. Connecting SCSI Drives	103
SCSI Requirements	103
Connecting SCSI Drives	105
Quick Formatting SCSI Drives	106
General Hard Drive Maintenance	107
Using Macintosh Drives on Windows Systems	109
Appendix B. DigiTest Error Codes	111
Appendix C. Windows System Optimizations	113
Troubleshooting	113
Advanced Settings	113
Appendix D. Digidesign ASIO Driver (Windows Only)	115
Introduction	115
Compatible Software	115
Installing the ASIO Driver	115
Changing ASIO Driver Settings	116
Appendix E. Digidesign WaveDriver (Windows Only)	119
Introduction	119
Compatible Software	119
Installing the WaveDriver	120
Configuring WaveDriver for Windows Media Player and Other Third-Party WaveDriver Programs	120
Appendix F. Digidesign CoreAudio Driver (Macintosh Only)	121
Introduction	121
Compatible Software	121
Installing the CoreAudio Driver	121
Configuring the Digidesign CoreAudio Driver	122
Appendix G. Configuring AMS (Mac OS X Only)	127
Index	131

chapter 1

Welcome to Pro Tools|HD

Welcome to Pro Tools|HD. Pro Tools|HD-series audio cards and interfaces bring high-definition digital audio recording, editing, signal processing, mixing, and I/O capabilities to Pro Tools.

This guide covers installation and configuration of Pro Tools|HD hardware and Pro Tools software on Windows and Macintosh platforms. System and installation tests are provided, as well as an introduction to Pro Tools software.

Pro Tools TDM Systems

HD-Series Systems

Pro Tools 6.4 on Windows or Macintosh supports the following systems:

Pro Tools|HD 1, HD 2 Accel, and HD 3 Accel

These Pro Tools|HD systems include:

- HD Core card
- HD Accel card; HD 2 Accel and HD 3 Accel come with one and two HD Accel cards, respectively (HD 1 does not include an HD Accel card)
- Pro Tools TDM software
- Digidesign audio interface (sold separately). See “Audio Interfaces” on page 2.

- DigiLink cable (to connect the HD card to an audio interface)
- TDM FlexCable (to connect two HD cards); one TDM Flex Cable per each HD Accel card (HD 1 does not include a TDM FlexCable)



Pro Tools 6.4 supports earlier Pro Tools|HD 1, HD 2, and HD 3 systems (Pro Tools 6.4 does not require an HD Accel card). For more information, see “Pro Tools|HD 1, HD 2, and HD 3” on page 1.

Pro Tools|HD 1, HD 2, and HD 3

These Pro Tools systems consist of original HD-series cards only (HD Core and HD Process), and do not include an HD Accel card.

A Pro Tools|HD system includes:

- HD Core card
- HD Process card; HD 2 and HD 3 come with one and two Process cards, respectively (HD 1 does not include a Process card)
- Pro Tools TDM software
- Digidesign audio interface (sold separately)
- DigiLink cable (to connect the HD card to an audio interface)
- TDM FlexCable (to connect two HD cards); one TDM Flex Cable per each Process card (HD 1 does not include a TDM FlexCable)

Recording and Playback Capabilities

Pro Tools|HD 1

Pro Tools|HD 1 systems provide recording and playback of 24-bit and 16-bit audio files with the following track counts:

- Up to 96 tracks at 44.1 kHz or 48 kHz
- Up to 48 tracks at 88.2 kHz or 96 kHz
- Up to 12 tracks at 176.4 kHz or 192 kHz

HD Accel-Equipped Systems

Pro Tools|HD 2 Accel and HD 3 Accel systems (which includes any HD-series systems with at least one HD Accel card) provide recording and playback of 24-bit and 16-bit audio files with the following track counts:

- Up to 192 tracks at 44.1 kHz or 48 kHz
- Up to 96 tracks at 88.2 kHz or 96 kHz
- Up to 36 tracks at 176.4 kHz or 192 kHz.

Non-HD Accel Systems

Pro Tools|HD 2 and HD 3 systems (original HD-series system with no HD Accel cards) provide recording and playback of 24-bit and 16-bit audio files with the following track counts:

- Up to 128 tracks at 44.1 kHz or 48 kHz
- Up to 64 tracks at 88.2 kHz or 96 kHz
- Up to 24 tracks at 176.4 kHz or 192 kHz

All Pro Tools|HD systems provide:

- TDM digital mixing and DSP plug-ins
- Non-linear, random-access editing and mix automation
- MIDI recording, playback, and editing

Audio Interfaces

To record and play audio you must have at least one of the following Digidesign audio interfaces:

192 I/O Audio Interface

- Supports sample rates up to 192 kHz. (At least one 192 I/O or 192 Digital I/O must be connected to your Pro Tools|HD system for 192 kHz recording, processing, and playback.)

- Supports both analog and digital connections, including AES/EBU, S/PDIF, TDIF, and ADAT Optical:

- Digital (Digital I/O Card): eight channels, DB-25 (AES/EBU and TDIF), or one pair of Lightpipe (ADAT Optical) connectors. Expandable up to 16 channels digital I/O with the addition of the 192 Digital expansion card.
- Analog: eight channels, DB-25 (balanced) connectors, inputs selectable between +4 dBu or -10 dBV, outputs +4 dBu only. Expandable up to 16 analog inputs or 16 outputs using an optional 192 AD or 192 DA expansion card, respectively.
- Digital (Enclosure): two channels, XLR (AES/EBU) connectors; two channels RCA (S/PDIF) connectors.
- Optical (Enclosure): eight channels, one pair of Lightpipe (ADAT Optical) connectors (switchable to two channels, S/PDIF).
- Word Clock in and out receive or send 1x Word clock (configurable to 256x for Legacy support, see “Optional Legacy I/O Audio Interfaces” on page 3).

192 Digital I/O Audio Interface

- Supports sample rates up to 192 kHz. (At least one 192 I/O or 192 Digital I/O must be connected to your Pro Tools|HD system for 192 kHz recording, processing, and playback.)
- Supports digital connections, including AES/EBU, S/PDIF, TDIF, and ADAT Optical:
 - Digital (2 Digital I/O Cards): 16 channels, DB-25 (AES/EBU and TDIF), or two pairs of Lightpipe (ADAT Optical) connectors.
 - Digital (Enclosure): two channels, XLR (AES/EBU) connectors; two channels RCA (S/PDIF) connectors.
 - Optical (Enclosure): eight channels, one pair of Lightpipe (ADAT Optical) connectors (selectable to two channels, S/PDIF).
 - Word Clock in and out receive or send 1x Word clock (configurable to 256x for Legacy support, see “Optional Legacy I/O Audio Interfaces” on page 3).

96 I/O Audio Interface

- Supports sample rates up to 96 kHz.
- Supports analog and digital connections, including AES/EBU, S/PDIF, and ADAT optical:
 - Analog: eight channels, 1/4-inch TRS (balanced or unbalanced) connectors, +4 dBu or –10 dBV
 - Digital: two channels, XLR (AES/EBU) connectors; two channels, RCA (S/PDIF) connectors
 - Optical: eight channels, one pair of Lightpipe (ADAT Optical) connectors (switchable to two channels, S/PDIF)
 - Word Clock in and out receive or send 1x Word clock (configurable to 256x for Legacy support, see “Optional Legacy I/O Audio Interfaces” on page 3)

96i I/O Audio Interface

- ◆ Supports sample rates up to 96 kHz.
- 16 discrete channels of input, and two channels of output, with 4-segment LED meters on each channel. Audio inputs and outputs include:
 - 16 channels of 24-bit, 96-kHz capable analog input, with adjustable input sensitivity
 - Two channels of 24-bit, 96-kHz capable analog output, with selectable operating level
 - Two channels of 24-bit, 96 kHz-capable digital S/PDIF RCA input and output
- Loop Sync In and Out
- External Clock In and Out
- Expansion DigiLink port

Optional Legacy I/O Audio Interfaces

For additional input and output channels, older Digidesign audio interfaces (or *Legacy I/Os*) can be connected to the 192 I/O, 192 Digital I/O, or 96 I/O (the 96i I/O does not support Legacy interfaces). Legacy interfaces can only be used with 44.1 kHz or 48 kHz sessions. These include:

888|24 I/O Audio Interface

- Analog: eight channels, XLR (balanced or unbalanced) connectors, selectable between +4 dBu or –10 dBV
- Digital: eight channels, XLR (AES/EBU) connectors; two channels, RCA (S/PDIF) connectors

882|20 I/O Audio Interface

- Analog: eight channels, 1/4-inch TRS (balanced or unbalanced) connectors, selectable between +4 dBu and –10 dBV
- Digital: two channels, RCA (S/PDIF) connectors

1622 I/O Audio Interface

- Analog: sixteen input channels and two output channels, 1/4-inch TRS (balanced or unbalanced) connectors. Inputs are selectable from +4 dBu to -10 dBV line levels and higher in 2 dB gain steps; outputs are selectable between +4 dBu or -10 dBV.
- Digital: two channels, RCA (S/PDIF) connectors.

Digidesign 24-bit ADAT Bridge I/O and Original ADAT Bridge I/O

- Optical: sixteen channels, a pair of Lightpipe (ADAT) connectors.
- Analog output: two channels, 1/4-inch TRS (balanced) connectors, selectable between +4 dBu and -10 dBV.
- Digital: two channels, XLR (AES/EBU); two channels RCA (S/PDIF) connectors.

 *The original 888 I/O and 882 I/O interfaces are not supported with Pro Tools|HD.*

System Requirements

Compatibility Information

Digidesign can only assure compatibility and provide support for hardware and software it has tested and approved.

For a list of Digidesign-qualified computers, operating systems, hard drives, and third-party devices, refer to the latest compatibility information on the Digidesign Web site (www.digidesign.com/compato).

MIDI Requirements

USB MIDI interfaces work effectively with Pro Tools systems on Windows or Macintosh. Serial MIDI interfaces are supported on Windows systems only.

 *Only USB MIDI interfaces are compatible with Pro Tools systems for Mac OS X. Modem-to-serial port adapters and serial MIDI devices are not supported.*

Refer to the Digidesign Web site (www.digidesign.com) for a list of supported adapters.

Hard Drive Requirements

For optimal audio recording and playback, all Pro Tools TDM systems require one or more Digidesign-qualified drives.

Drive Formats

Windows Windows XP systems should use drives formatted with FAT32 or NTFS file system (NTFS preferred).

Macintosh Macintosh systems should use drives formatted with HFS or HFS+ file system only.

 *The UNIX File System (UFS) is not supported with Pro Tools on Mac OS X.*

Hard drive performance depends on factors including system configuration, number of tracks, session sample rate, density of edits, and the use of crossfades and other processes such as Beat Detective in a session.

Be sure to check the latest compatibility information on the Digidesign Web site for SCSI and FireWire requirements for maximum track counts on Windows and Macintosh (www.digidesign.com/compato).

SCSI Hard Drives

For maximum recording and playback performance, Digidesign recommends qualified SCSI hard drives and a qualified SCSI host bus adapter (HBA) card or (on Windows systems) a qualified built-in SCSI HBA connector on the motherboard.

Qualified SCSI drives yield up to 32 tracks per drive with 24-bit audio

Windows On Windows XP, up to six SCSI drives can be used simultaneously.

Macintosh On Mac OS X, up to four SCSI drives can be used simultaneously.

FireWire Hard Drives

Digidesign recommends qualified FireWire drives and (on Windows only) a qualified FireWire host adapter.

Qualified FireWire drives yield up to 24 tracks per drive with 24-bit audio.

Windows On Windows XP systems without an expansion chassis, up to six FireWire drives can be used simultaneously. On Windows XP systems with Pro Tools cards installed in an expansion chassis, up to four FireWire drives can be used simultaneously.

Macintosh On Mac OS X, up to eight FireWire drives can be used simultaneously.

IDE/ATA Hard Drives

A qualified internal IDE/ATA drive yields up to 32 tracks of 24-bit audio, at 44.1 kHz or 48 kHz when used as a dedicated audio drive.



For maximum performance, Digidesign recommends the use of SCSI hard drives. IDE hard drives provide limited track count performance and are not supported when an Expansion Chassis is used. For more information regarding Expansion Chassis operating procedures, see the Pro Tools Expanded Systems Guide.



Visit the Digidesign Web site (www.digidesign.com) for a list of qualified hard drives and SCSI HBA cards.

Avoid Recording to System Drives

Although Pro Tools will let you record to your system drive, this is generally not recommended. Recording and playback on system drives results in lower track counts and fewer plug-ins.



Digidesign does not recommend recording to system drives. Record to system drives only when necessary.

Hard Disk Storage Space

Mono audio tracks recorded with 16-bit resolution at 44.1 kHz (CD quality) require approximately 5 MB of hard disk space per minute.

The same tracks recorded with 24-bit resolution require about 7.5 MB per minute. Table 2 on page 6 lists the required disk space for certain track numbers and track lengths, to help you estimate your hard disk usage.

Table 2. Required hard drive space for audio tracks

Number of tracks and length	16-bit at 44.1 kHz	16-bit at 48 kHz	24-bit at 44.1 kHz	24-bit at 48 kHz
1 mono track, 1 minute	5 MB	5.5 MB	7.5 MB	8.2 MB
1 stereo track (or two mono tracks), 5 minutes	50 MB	55 MB	75 MB	83 MB
1 stereo track (or two mono tracks), 60 minutes	600 MB	662 MB	900 MB	991 MB
24 mono tracks, 5 minutes	600 MB	662 MB	900 MB	991 MB
24 mono tracks, 60 minutes	7 GB	7.8 GB	10.5 GB	11.6 GB
32 mono tracks, 5 minutes	800 MB	883 MB	1.2 GB	1.3 GB
32 mono tracks, 60 minutes	9.4 GB	10.4 GB	14 GB	15.4 GB

Digidesign Registration

Make sure to complete and return the registration card included with your Pro Tools|HD system. Registered users will receive periodic software update and upgrade notices. Refer to the registration card for information on technical support.

About the Pro Tools Guides

In addition to the printed guides included with your system, PDF versions of the Pro Tools guides are installed automatically with Pro Tools, and are accessible from the Pro Tools Help menu (Windows) or Pro Tools menu (Macintosh). To view or print the PDF guides, you can install Acrobat Reader (included on the Pro Tools Installer CD-ROM).

Conventions Used in This Guide

Digidesign guides use the following conventions to indicate menu choices and key commands:

Convention	Action
File > Save Session	Choose Save Session from the File menu
Control+N	Hold down the Control key and press the N key
Control-click	Hold down the Control key and click the mouse button
Right-click (Windows)	Click with the right mouse button

The following symbols are used to highlight important information:

 *User Tips are helpful hints for getting the most from your system.*

 *Important Notices include information that could affect your data or the performance of your system.*

 *Shortcuts show you useful keyboard or mouse shortcuts.*

 *Cross References point to related sections in other Digidesign guides.*

About www.digidesign.com

The Digidesign Web site (www.digidesign.com) is your best source for information to help you get the most out of your Pro Tools system. The following are just a few of the services and features available.

Support Contact Digidesign Technical Support or Customer Service; download software updates and the latest online manuals; browse the Compatibility documents for system requirements; search the online Answerbase; join the worldwide Pro Tools community on the Digidesign User Conference.

Training and Education Become a certified Pro Tools Operator or Expert; study on your own using courses available online, or find out how you can learn in a classroom setting at a certified Pro Tools Training Center.

Products and Developers Learn about Digidesign products; download demo software; learn about our Development Partners and their plug-ins, applications, and hardware.

News and Events Get the latest news from Digidesign; sign up for a Pro Tools demo.

To learn more about these and other resources available from Digidesign, visit our Web site (www.digidesign.com).

chapter 2

Windows Configuration

Installation of a Pro Tools|HD-series system on a Windows computer includes the following steps:

- 1 Install Windows XP. (See “Installing Windows XP” on page 9.)
- 2 Configure your computer and its hardware components in preparation for Pro Tools installation. (See “Configuring Your Computer” on page 10.)
- 3 Configure Windows system software settings for compatibility and optimal performance. (See “Windows System Settings” on page 13.)
- 4 Install Pro Tools hardware. (See “Installing Pro Tools Hardware” on page 17.)
- 5 Install Pro Tools TDM software. (See “Installing Pro Tools Software” on page 23.)
- 6 Check your Pro Tools system. (See “Checking Your HD System” on page 26.)
- 7 Configure your Pro Tools system. (See “Configuring Pro Tools” on page 29.)

Installing Windows XP

If you do not already have Windows XP installed on your computer, you will need to install Windows XP Professional edition or Windows XP Home edition. Pro Tools requires an activated version of Windows XP with administrator privileges.

For best performance, Digidesign strongly recommends a clean installation of Windows on a newly formatted drive or partition rather than upgrading the operating system.

⚠ *If you are changing or upgrading your operating system, be sure to deauthorize any key disk authorized plug-ins before changing or upgrading to avoid losing any authorizations. See the iLok Usage Guide for information on the iLok Smart Key for software authorizations.*

Configuring Your Computer

To ensure optimum performance with Pro Tools, configure your computer before installing Pro Tools hardware and software.

⚠ *Before you make any changes to your computer's system settings, make a backup copy of your registry (where many of these essential settings are stored). By doing so, you will be able to restore your system's original settings in case of trouble. Consider acquiring a disk recovery utility such as Norton Ghost for additional security. See your Windows XP documentation for details.*

If your computer does not provide the BIOS configuration options included in this section, or if you do not feel comfortable changing system parameters, consult with a Windows system administrator, computer dealer, or manufacturer for assistance.

Configuring the BIOS

BIOS (Basic Input/Output System) parameters vary depending on the make and model of the computer. Refer to the documentation that came with your computer for more details.

Different BIOS manufacturers often use different names to describe the same system function. Some manufacturers do not provide a particular configuration option at all. The names and options that appear in your computer's BIOS may differ from those described in this section.

 *The following BIOS settings are not applicable to the Compaq Evo W8000 and the IBM Intellistation M Pro 6850.*

To modify your computer's BIOS:

- 1 Start or restart your computer.
- 2 While the computer is starting up, enter BIOS Setup by pressing the appropriate key (usually indicated in the startup message) on your computer keyboard. The F1, F2, or the Delete keys are commonly used.
- 3 In the appropriate page of the BIOS Setup, disable PCI Parity. If the PCI Parity option isn't available on your computer, skip this step.
- 4 If you will be using SCSI drives or devices, and your computer is equipped with built-in SCSI hardware, enable SCSI support. SCSI support parameters are typically found on the Devices & I/O Options page of the BIOS setup utility. If you do not have built-in SCSI hardware and are using a SCSI host bus adapter (HBA) card instead, you do not need to enable SCSI support.
- 5 Disable Power Management, if present.
- 6 Enable PCI Dynamic Bursting, if present.
- 7 Save the new BIOS settings.
- 8 Exit BIOS setup and restart your computer.

Configuring the SCSI BIOS

If you are using SCSI drives or devices, you must modify the settings of your built-in SCSI hardware or SCSI host bus adapter card. This allows SCSI hard drives to work properly with Pro Tools. This procedure varies on different computers. Refer to the documentation that came with your computer.

To modify your computer's SCSI BIOS:

- 1 Start or restart your computer.
- 2 While the computer is starting up, when the text message regarding the SCSI BIOS appears, press the key combination listed on the screen to enter the SCSI BIOS setup utility.
- 3 Refer to your SCSI host bus adapter card documentation to set the following parameters:
 - For each SCSI ID and SCSI channel connected to your audio drives, set the Maximum Sync Transfer Rate parameter to 20 MB/sec for the ATTO EPCI-DC, or to Ultra 160 for Ultra 160 cards.
 - If you are using an ATTO host bus adapter card, change the PCI Burst Size to 128 Bytes and the Burst Length Selection Timeout to 16 ms (UL3D only).
 - If you are using an Adaptec host bus adapter card, enable the Host Adapter BIOS option.
- 4 Save the new SCSI BIOS settings.
- 5 Exit SCSI BIOS setup and restart your computer.

Updating the SCSI BIOS

If you are using an ATTO SCSI HBA card, you may need to update its SCSI BIOS. When starting your computer, you will see which version of the ATTO SCSI BIOS is installed on the SCSI card. If it is not version 1.68 or higher, you will need to flash the SCSI BIOS with 1.68 or higher ATTO SCSI BIOS (flash.bat).

To update the BIOS on the ATTO SCSI card:

- 1 Insert a High Density PC formatted floppy disk in your floppy drive (this needs to be a DOS boot disk).
- 2 Copy the DOS folder from the ATTO folder on the Pro Tools Installer CD-ROM to the floppy disk.
- 3 Shut down your computer.
- 4 Disconnect any hard drives connected to the SCSI card.
- 5 Start your computer with the floppy disk in the floppy drive.
- 6 From within DOS, CD to the DOS/UTILITY folder and run flash.bat.
- 7 When prompted, press Control+Z.

The SCSI BIOS will be updated. This may take a few minutes.

 *Do not interrupt this process or your system may be damaged.*

 *For more information, see the flash.txt in the DOS/UTILITY folder.*

Installing SCSI Drivers

For Pro Tools to run at maximum efficiency with SCSI Host Bus Adapters and SCSI drives, install a Digidesign approved SCSI driver (ATTO or Adaptec, depending on the card you are using).



Check Digidesign's Compatibility Documents for a list of Digidesign approved computers and supported SCSI driver versions. Compatibility Documents and other resources are available at the Digidesign Web site (www.digidesign.com).

Installing the Adaptec SCSI Driver

If you need to install the Adaptec driver, refer to the driver manufacturer's documentation.

The full name of the Adaptec driver for the IBM M Pro or Compaq Evo W8000 is:

- Adaptec
AHA290/291/294x/394x/4944/ AIC78xx

Installing the ATTO SCSI Drivers

The full name of the ATTO driver is:

- ATTO ExpressPCI

To install the ATTO Windows device driver:

- 1** Start your computer. Note the version of the ATTO SCSI BIOS when booting. If it is version 1.6.6, proceed to the next step. If it is not version 1.6.6, you will need to flash the ATTO SCSI BIOS (see "Updating the SCSI BIOS" on page 11).
- 2** Insert the Pro Tools Installer CD-ROM in your CD-ROM drive.
- 3** Open the System Control Panel.
- 4** Click the Hardware tab.
- 5** Click Device Manager.

- 6** Select SCSI and RAID controllers.
- 7** Double-click the LSI PCI SCSI Adapter.
- 8** Click the Driver tab.
- 9** Click Update Driver.
- 10** Select "Install from specified location."
- 11** Select "Don't search, I'll choose the driver to install."
- 12** Click Next.
- 13** Click Have Disk.
- 14** Click Browse and navigate to the ATTO folder on the Pro Tools Installer CD-ROM.
- 15** Select EXPRESS.INF and click Open.
- 16** Click OK.
- 17** Click Next.
- 18** Click Finish.
- 19** Click Close.
- 20** If you have a dual-channel SCSI card, repeat steps 8–20 for the second channel.
- 21** Click OK.

After Configuring your Computer

Restart your computer to verify basic system operation with your new settings. While not required, this may resolve any conflicts or incompatibilities revealed by changes made to your BIOS, SCSI configuration, or other computer hardware and settings.

If you experience problems, check your settings again, then try resetting one at a time and restarting until you identify which settings might be the source of the problem. Resolve any startup problems before proceeding with your Pro Tools installation. For troubleshooting and other Windows system information, see Appendix C, "Windows System Optimizations."

Windows System Settings

Configure Window system settings, as follows:

Required Settings These instructions must be followed before installing Pro Tools.

Recommended Configuration These instructions should be followed to optimize your system's capabilities, or to let older computers run Pro Tools.

Required Settings

To ensure optimum performance with Pro Tools, configure the following Control Panel settings for your version of Windows XP.

 *When finished updating required Windows system settings, restart your computer.*

Disable Hyper-Threading

For Pentium IV computers with Hyper-Threading, disable Hyper-Threading in the BIOS.

Enable DMA

Enabling your computer's DMA (Direct Memory Access) frees up CPU bandwidth so your computer can do other Pro Tools tasks.

In most cases the DMA option will already be set correctly, as Windows XP detects and activates DMA mode by default.

To enable DMA for any IDE hard drives:

- 1 Choose Start > Control Panel.
- 2 In Classic view, launch System.
- 3 Click the Hardware tab.
- 4 Under Device Manager, choose Device Manager.

5 In the Device Manager window, double-click IDE ATA/ATAPI controllers, then double-click the Primary IDE Channel for your IDE hard drive.

6 Click the Advanced Settings tab.

7 For each device, set the Transfer Mode to "DMA if available," and click OK.

In most cases, this will already be set correctly as Windows XP will detect and activate DMA mode by default.

8 Repeat steps 5–7 for any additional IDE Channels.

9 Close the Computer Management window.

Disable System Standby and Power Management

When using Pro Tools, the Windows System Standby power scheme must be set to Always On. This helps prevent long record or playback passes from stopping due to system resources powering down.

To configure Windows Power Management:

- 1 Choose Start > Control Panel.
- 2 In Classic View, launch Power Options.
- 3 Click the Power Schemes tab.
- 4 From the Power Schemes pop-up menu, select Always On, and click OK.

This sets System Standby, System Hibernate, and "Turn off hard disks" to Never.

Disable ClearType Font Smoothing

When using Pro Tools, the Effects “Clear Type” setting must be disabled.

To disable ClearType font smoothing:

- 1 Choose Start > Control Panel.
- 2 In Classic View, launch Display.
- 3 Click the Appearance tab.
- 4 Click Effects.
- 5 Deselect “Use the following methods to smooth edges of screen fonts.”
- 6 Click OK to save your settings and close the Effects dialog.
- 7 Click OK.

Completing Required Windows System Settings

When finished updating required Windows system settings, restart your computer.

 *If problems occur after configuring all required and suggested settings, see Appendix C, “Windows System Optimizations” for information on troubleshooting and advanced settings.*

Recommended Configuration

Pro Tools can also be affected by other software and hardware drivers installed on your computer. For best performance, it is recommended (but not required) that you:

- Avoid running other Windows programs at the same time as Pro Tools.
- Turn off any software utilities that run in the background, such as Windows Messenger, calendars, and disk maintenance programs.
- Turn off any nonessential USB devices while using Pro Tools
- If your video display card supports it, enable Bus Mastering in the manufacturer’s Control Panel.
- Disable any networking cards (other than any 1394 “FireWire” card that you might use to connect an external drive to your system).



For information on disabling networking cards, see “Disabling Network Cards” on page 113.

Pro Tools Hardware Overview

The number of Pro Tools TDM cards in your system will differ depending on your system configuration. Card components for each configuration are listed below.

 *If you are using an Expansion Chassis to increase the number of cards in your system, refer to the Expanded Systems Guide included with your Pro Tools system.*

Pro Tools|HD Hardware

Pro Tools|HD hardware is available in the following configurations:

Pro Tools|HD 1 Includes a single HD Core card

Pro Tools|HD 2 Accel Includes an HD Core card, an HD Accel card, and a TDM FlexCable for connecting the HD Core to the HD Accel card

Pro Tools|HD 3 Accel Includes an HD Core card, two HD Accel cards, and two TDM FlexCables for connecting the cards to each other

 *Additional HD Accel and HD Process cards may be added to expand your Pro Tools system. HD Accel cards are fully compatible with HD Process cards. Up to seven HD cards are supported in a single Pro Tools|HD system.*

HD Core Card

All Pro Tools|HD systems include an HD Core card. The HD Core card is the only Pro Tools|HD card that does not require the presence of any other HD-series cards. (Pro Tools|HD 1 systems are comprised of a single HD Core card).

The HD Core card provides up to 96 tracks of direct-to-disk recording and playback, as well as DSP power for mixing and plug-in processing. The HD Core card supports up to 24-bit and up to 192 kHz sessions.

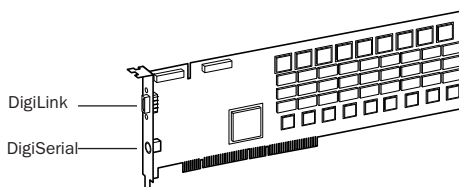

HD Core card

The HD Core card includes a single DigiLink port for connecting up to 32 channels of audio input and output to your Pro Tools|HD system.

The DigiSerial port on the HD Core card is for connecting a Digidesign SYNC I/O. This connector is an 8-pin mini-DIN.

 *The DigiSerial port on HD Core cards does not support MachineControl connections, nor does it support the Digidesign Universal Slave Driver (USD). Use the machine ports on the Digidesign SYNC I/O for Pro Tools MachineControl 9-pin connections. A COM port (not a DigiSerial port) is required for Remote 9-pin Deck Emulation mode (only).*

 *If your HD Core card has two DigiSerial ports, use the DigiSerial port closest to the DigiLink connector.*

HD Accel Card

The HD Accel card is included in Pro Tools|HD 2 Accel and Pro Tools|HD 3 Accel systems. The HD Accel card is an expansion card, and requires the presence of at least one HD Core card.

The HD Accel card provides up to 32 additional tracks of direct-to-disk recording and playback, as well as DSP power for mixing and plug-in processing. The HD Accel card supports up to 24-bit and up to 192 kHz sessions.

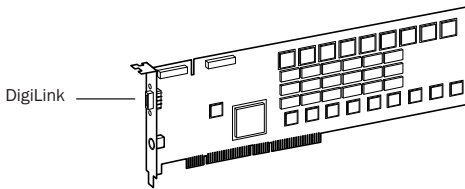

HD Accel card

The HD Accel card includes a single DigiLink port for connecting up to 32 channels of audio input and output to your Pro Tools|HD system.

The DigiSerial port on the HD Accel card does not offer any functionality.

HD Process Card

The HD Process card is the predecessor to the HD Accel card. Like HD Accel cards, HD Process cards are expansion cards, requiring at least one HD Core card.

 *HD Process cards are fully compatible with HD Accel cards and HD Core cards in expanded Pro Tools|HD systems.*

The HD Process card provides up to 32 additional tracks of direct-to-disk recording and playback (up to a maximum of 128 tracks in systems without an HD Accel card), as well as DSP power for mixing and plug-in processing. The HD Process card supports up to 24-bit and up to 192 kHz sessions.

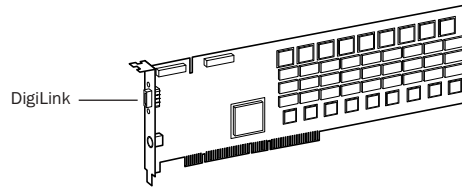

HD Process card

The HD Process card includes a single DigiLink port for connecting up to 32 additional channels of audio input and output to your Pro Tools|HD system (up to a maximum of 96 channels).

The DigiSerial port on an HD Process card does not offer any functionality.

TDM FlexCable

The TDM FlexCable is used to connect a pair of cards in your Pro Tools system so they can share data along the TDM bus. Additional FlexCables are required to connect additional cards. One FlexCable comes with each HD Accel card.

 *The TDM FlexCable is a flexible printed circuit board with delicate traces. Do not overbend, twist, or pinch the cable. Doing so may cause unpredictable behavior in Pro Tools as well as harm to your system.*

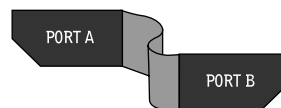

TDM FlexCable

Installing Pro Tools Hardware

Disabling Driver Signing Warnings

Before you install Pro Tools cards, temporarily disable the Driver Signing warning option. This expedites and automates much of the installation process. If you do not temporarily disable this option, warning messages (that you are installing an unsigned driver) will appear for each DSP chip detected during software installation.

To disable the warning option:

- 1 Open the System Control Panel.
- 2 Click the Hardware tab in the System Control Panel.
- 3 Click the Driver Signing button.
- 4 Select “Ignore—Install the software anyway and don’t ask for my approval.”
- 5 Click OK twice.
- 6 Turn your computer off.
- 7 Proceed to install your Pro Tools cards.

Installing Pro Tool|HD Cards

This section shows how to install Pro Tools HD cards into a Windows computer. To install cards into an expansion chassis, see the *Expanded Systems Guide*.

To install Pro Tools cards:

- 1 Turn off your computer and any peripherals. Leave your computer’s power cable plugged in so the computer is grounded.
- 2 Disconnect all cables attached to the computer (such as hard drives, displays, USB and FireWire devices) except for the power cable.
- 3 Open the computer case.

 Before handling any card, discharge static electricity from your clothes or body by touching a grounded metal surface, such as the power supply case inside your computer.

- 4 Remove the metal access port cover behind the PCI slot you want to use by removing the screw and sliding the cover out from the access port.
- 5 Install the HD Core card in the first PCI slot.
- 6 If you are installing additional Pro Tools cards, skip to the next step. If you have no additional cards to install, do the following:
 - Secure the card in place with the slot access port screw you removed earlier.
 - Close the computer case.
 - Skip to “Connecting Audio Interfaces” on page 19.
- 7 Install the first HD Accel card (if any) in the second PCI slot.
- 8 Install any remaining HD Accel cards in the remaining consecutive PCI slots.
- 9 Install any HD Process cards in the remaining consecutive PCI slots (64- or 32-bit).
- 10 If you are installing a SCSI HBA card, install it in the highest-numbered remaining slot.

Check to be sure that your cards are installed in the following order:

- HD Core card
- HD Accel cards
- HD Process cards, if any
- SCSI host bus adapter (HBA) card
- Display card for your computer monitor

 The above guidelines may include optional cards not present in your system.

11 Secure each card in place with the slot access port screws you removed earlier.

12 Proceed to “Connecting Pro Tools|HD Cards” on page 18.

⚠ *The IBM Intellistation M Pro 6850 may not boot after updating the BIOS or changing the order of Pro Tools cards. Should this problem occur, remove all plug and play cards and you will be able to boot Windows, then shut down and re-install the cards according to the installation instructions in “Installing Pro Tool|HD Cards” on page 17. You should now be able to boot Windows.*

Connecting Pro Tools|HD Cards

In HD systems that include more than one card, you must connect all the HD cards to each other with TDM FlexCables.

Each HD card has two ports along the top of the card, labeled *Port A* and *Port B*. The FlexCable has two connectors, also labeled *Port A* and *Port B*, to ensure proper connection. Data communication across multiple HD cards is achieved by connecting *Port B* of the first card to *Port A* of the next card with a TDM FlexCable.

💡 *The first FlexCable always goes from *Port B* on the HD Core card to *Port A* on the Accel or Process card, as described in the following steps.*

To connect HD cards with the TDM FlexCable:

1 Shape the FlexCable before installing it on your HD cards by grasping the cable with both hands with its printed side facing you, and moving the *Port B* portion of the cable straight towards you and inwards, as shown below. Do not bend the cable more than you need to, as you may damage the traces in the cable.

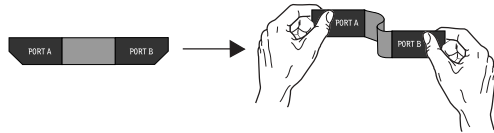

Preparing TDM FlexCable for installation

2 Slide the FlexCable into the notch of the *first* card, so that the *Port B* connector of the FlexCable can be aligned with *Port B* of the first card; and the *Port A* connector of the FlexCable can be aligned with *Port A* of the second card, as shown below.

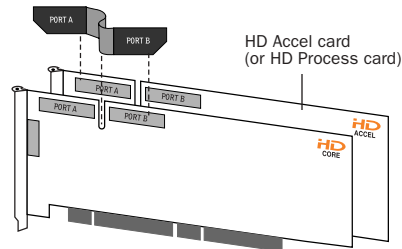

Inserting TDM FlexCable

3 Connect the Port A connector of the FlexCable to Port A on the second card. Push down gently but firmly until the cable is fully connected to the card. Attach the other end of the FlexCable (labeled Port B) to Port B on the first card.

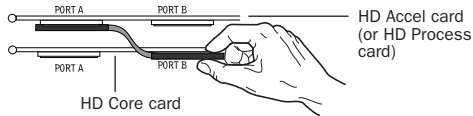

Top view of two HD cards connected with TDM FlexCable

4 Verify the connection, as shown below (orientation may be different depending on your type of CPU or chassis).

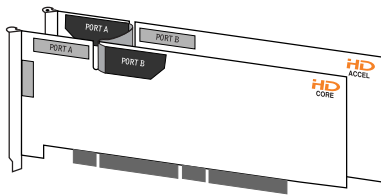

Side view of two HD cards connected with TDM FlexCable

5 For systems with more than two cards, connect each additional card to its preceding card. Use FlexCables to connect card pairs together, as described above, until all cards are connected. (Each HD Accel card is packaged with a FlexCable.)

6 Close the computer case.

7 Proceed to “Connecting Audio Interfaces” on page 19.

Connecting Audio Interfaces

Each Pro Tools|HD-series audio interface supplies up to 16 channels of input and output to your system. Audio interfaces are connected directly to Pro Tools|HD cards, or through the Expansion ports on other HD-series interfaces.

Each HD card supports up to 32 channels. To get a full 32 channels of I/O from one card, you can connect, or *daisy-chain*, a second 16-channel HD I/O to the first HD I/O that is connected directly to the HD card.

Pro Tools|HD supports up to a maximum of eight 192 I/Os, 192 Digital I/Os, or 96 I/Os. Up to four 96i I/Os can be used simultaneously.

For examples of connecting multiple HD I/Os, see Figure 1 and Figure 2 on page 21.

⚠ *HD audio interfaces need room at their sides to maintain proper air flow for cooling. It is important to leave room for air intake and ventilation on the sides of the unit. Do not block the sides of the unit or disconnect the internal fan. If the units are rack-mounted in a case, remove the case lids or doors before operating the system. Failure to do so can result in the units overheating very quickly, which can permanently damage sensitive components.*

Legacy audio interfaces can also be connected to the 192 I/O, 192 Digital I/O, or 96 I/O (the 96i I/O does not support Legacy interfaces). These include: 888|24 I/O, 882|20 I/O, 1622 I/O, 24-bit ADAT Bridge I/O, and the original ADAT Bridge I/O. The original 888 I/O and 882 I/O interfaces are not supported with Pro Tools|HD.

To connect HD audio interfaces:

1 If you are using a single 192 I/O, 192 Digital I/O, 96 I/O, or 96i I/O, connect its Primary Port to the HD Core card with the DigiLink cable provided with the HD Core card. You must attach at least one 192 I/O, 192 Digital I/O, 96 I/O, or 96i I/O to your system in order for Pro Tools to launch.

▲ *If you have at least one 192 I/O or 192 Digital I/O in your system configuration, it must be connected to the HD Core card as the primary interface.*

2 Connect additional HD audio interfaces to subsequent Digidesign audio cards, or daisy-chain your I/Os (by connecting the Primary Port of the secondary I/O to the Expansion Port of the primary I/O).

If you are connecting both 192 I/O (or 192 Digital I/O) and 96 I/O audio interfaces to your system, connect the 192 I/O (or 192 Digital I/O) to your HD Core card, followed by any additional 192 I/O (or 192 Digital I/O) interfaces connected to the next highest-priority cards. Then connect 96 I/O interfaces to subsequent cards, or to other interfaces, then connect 96i I/O interfaces.

You can also connect a single HD I/O to each HD card in your system using the provided DigiLink cables. (However, there is no advantage to this configuration over daisy-chaining I/Os.)

3 If you are using two or more HD audio interfaces, connect the Loop Sync Out of each interface to the Loop Sync In of the next interface with the BNC cables included in your HD I/O packaging. Then, connect the Loop Sync Out of the last interface to the Loop Sync In of the primary interface.

4 If you are connecting a Digidesign Legacy audio interface (such as an 888|24 I/O, 882|20 I/O, 1622 I/O, or Digidesign ADAT Bridge I/O), continue with “Connecting an Additional 16 Channels of Audio with Legacy Audio Interfaces” on page 22. (The 96i I/O does not support Legacy interfaces.)

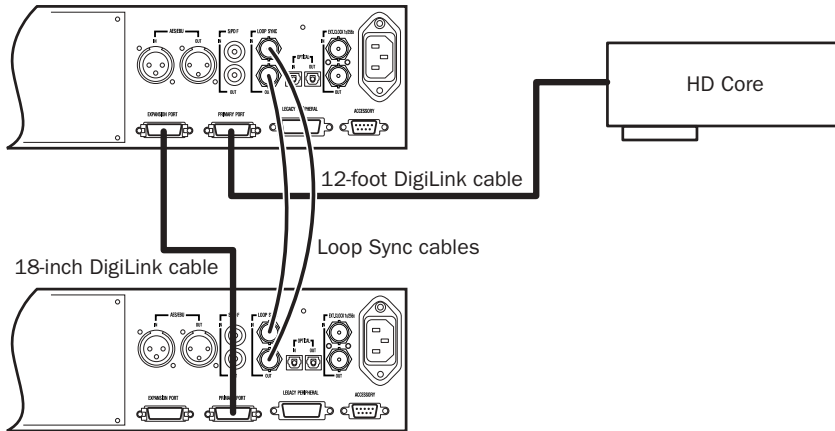

Figure 1. Two 96 I/Os (32-channel system)

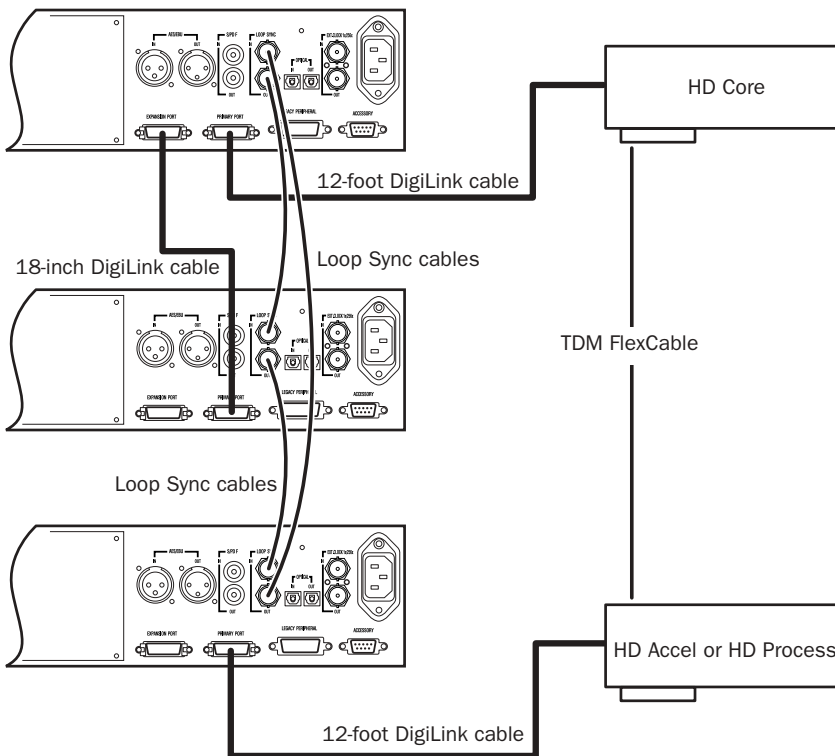

Figure 2. Three 96 I/Os (48-channel system)

Connecting an Additional 16 Channels of Audio with Legacy Audio Interfaces

Each 192 I/O, 192 Digital I/O, and 96 I/O can support 16 channels of audio to and from Digidesign Legacy I/Os. (The 96i I/O does not support Legacy I/Os.) Legacy I/Os include the 888|24 I/O, 882|20 I/O, 1622 I/O, 24-bit ADAT Bridge I/O, and the original ADAT Bridge I/O. The original 888 I/O and 882 I/O interfaces are not supported with Pro Tools|HD.

To connect Digidesign Legacy audio interfaces:

1 Connect the “MIX card” end of the peripheral cable that came with your Legacy audio interface (60-pin side) to the Legacy Port on the primary HD audio interface. Connect the other end to the Computer Port on the Legacy audio interface.

2 Connect any additional Legacy audio interfaces in the same manner, to HD audio interfaces connected directly to HD cards.

– or –

If you are using a Y cable (Legacy 16-channel peripheral cable adapter), connect this to the Legacy port first, then connect the audio interface peripheral cables to Port A and Port B of the Y cable.

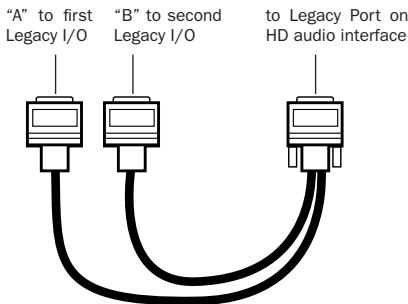

Optional 16-channel peripheral cable adapter

3 To properly clock the Legacy audio interface, connect the Ext. Clock output port on the HD I/O to the Slave Clock IN on the Legacy audio interface. The Legacy audio interface will switch to Slave mode once the proper clock is outputting from the HD I/O. Always use the Ext. Clock Out port of the same I/O to which the Legacy audio interface is attached.

If you are using the Y cable to connect multiple MIX-series audio interfaces, you must also connect the Slave Clock Out of the first Legacy interface to the Slave Clock In of the second Legacy interface with the provided BNC cable. You cannot clock more than two MIX-series audio interfaces from a single HD-series audio interface. If you have a third MIX-series audio interface, supply its 256x clock from the HD I/O to which its 60-pin cable is attached (either your second audio interface, or directly to an HD Accel or HD Process card).

 To ensure the proper functioning of Legacy audio interfaces (such as an 888|24 I/O or 882|20 I/O), launch Pro Tools and declare the Legacy audio interfaces in the Hardware Setup dialog before turning them on. Then quit Pro Tools, shut down your computer, turn on your audio interfaces, and turn on your computer.

 Before you turn on and configure your Legacy audio interfaces, turn down the volume of output devices. Very loud digital noise may be emitted before the Legacy audio interface is initialized.

Installing Pro Tools Software

To install Pro Tools software for TDM systems:

- 1 Start Windows, logging in with Administrator privileges. For details on Administrator privileges, refer to your Windows documentation.
- 2 Make sure you have configured all the required Windows system settings for your system, and rebooted your computer. See “Windows System Settings” on page 13 for more information.
- 3 Wait for the Found New Hardware Wizard dialog to appear and leave it open.
- 4 Insert the Pro Tools Installer CD-ROM for Windows in your CD-ROM drive. Locate and open the Pro Tools Installer folder, and double-click the Setup icon.
- 5 Click Next to begin installation.
- 6 Select the install location. For maximum reliability, install Pro Tools on your startup drive. Click Next.
- 7 Select available install options as needed.
- 8 Click Next to install the selected options.

 *A demo version of MacOpener is included on the Pro Tools Installer CD-ROM, and requires a separate installation process. Installing MacOpener is required only if you need to use HFS or HFS+ formatted hard drives. See “Installing MacOpener” on page 25 for more information.*

9 Select your work environment. This loads an initial set of Pro Tools Preferences that include some of the more popular settings for post production, audio, or audio with MIDI.

 *Preference settings can be customized at any time in Pro Tools. See the Pro Tools Reference Guide for more information about Preferences.*

10 Select whether to install the Surround Mixer plug-in. This plug-in is required for mixing, mastering, and monitoring in surround.

- Select “Yes – Monitor in Pro Tools Film Format” if your monitoring is configured for Film Format surround.
- Select “Yes – Monitor in ProControl (DTS Format)” if you are using a ProControl dedicated controller.
- Select “No – Stereo mixing only” if your monitoring is configured for Stereo.

 *The Surround Mixer can be installed at any time in Pro Tools. For instructions, see the Pro Tools Reference Guide.*

11 After making a selection, click Next.

Wait for the installer to finish installing all software components, drivers, and PACE System files before proceeding to the next step.

12 If QuickTime is not already installed, you will be prompted to install the Recommended QuickTime installer option (see “Installing QuickTime” on page 24). Follow the on-screen instructions to complete the QuickTime installation process.

13 When installation is complete, click Finish to restart your computer.

Installing QuickTime

(Optional)

QuickTime 6.5 or later is required for Pro Tools if you plan to include movie files in your sessions. QuickTime is available as a free download from the Apple Web site (www.apple.com).

Removing Pro Tools

If you need to remove Pro Tools from your computer, you can use the Add or Remove Programs command.

To remove Pro Tools from your computer:

- 1 Choose Start > Control Panel.
- 2 Launch Add or Remove Programs.
- 3 From the Currently installed programs list, select Digidesign Pro Tools.
- 4 Click the Change/Remove button.
- 5 Select Remove, and then click Next.
- 6 Click OK to remove Pro Tools.
- 7 Click Finish.

Installing Optional Software

Your Pro Tools Installer CD-ROM includes several software options.

Digidesign ASIO Driver 6.4

Digidesign ASIO Driver 6.4 is a single-client, multichannel sound driver that allows ASIO-compatible programs to record and play back through Digidesign hardware.

ASIO Driver 6.4 is automatically installed when you install Pro Tools 6.4.

Stand-Alone ASIO Driver Installer

Digidesign ASIO Driver 6.4 can be installed on Digidesign-qualified Windows XP systems with Pro Tools 6.4 (for example, if the ASIO Driver was uninstalled), or it can be installed as a stand-alone driver on systems that do not have any version of Pro Tools installed.

 For detailed information on using the Digidesign ASIO Driver, see Appendix D, “Digidesign ASIO Driver (Windows Only).”

Digidesign WaveDriver 6.4

Digidesign WaveDriver 6.4 is a single-client, multichannel sound driver that allows WaveDriver compatible programs to play back through Digidesign hardware.

WaveDriver 6.4 is automatically installed when you install Pro Tools 6.4.

Stand-Alone WaveDriver Installer

Digidesign WaveDriver 6.4 can be installed on Digidesign-qualified Windows XP systems with Pro Tools 6.4 (for example, if the WaveDriver was uninstalled), or it can be installed as a stand-alone driver on systems that do not have any version of Pro Tools installed.

 For detailed information on installing and using the Digidesign WaveDriver, see Appendix E, “Digidesign WaveDriver (Windows Only).”

Installing the Demo Session

(Optional)

The Pro Tools Installer CD-ROM includes a demo session that you can use to verify that your system is working.

To install the demo sessions:

- 1 Insert the Pro Tools Installer CD in your CD-ROM drive.
- 2 From your CD-ROM drive, choose Additional Files/Pro Tools Demo Session Installer.
- 3 Double-click Setup.exe.
- 4 Set the install location to your audio drive and click Install.
- 5 When installation is complete, click OK.

Installing MacOpener

With MacOpener 6.0.5 and higher, you can open and transfer Pro Tools sessions created on HFS and HFS+ formatted hard drives (Macintosh) to NTFS or FAT32 formatted hard drives (Windows).

 *Transfer drives can be used for storage, but not for playback or recording.*

 *The MacDrive utility can be used instead of MacOpener. Refer to the MacDrive Web site (www.macdrive.com).*

To share Pro Tools sessions between Macintosh and Windows systems, select the “Enforce Mac/PC Compatibility” option when creating the session, or when saving a session copy to a Windows audio drive formatted using NTFS or FAT32.

 *Avoid using MacOpener on HFS-formatted drives (it is recommended that you use NTFS or FAT32 instead). Use the Save Session Copy In command in Pro Tools to copy the session material to a Windows audio drive formatted using NTFS or FAT32.*

 *While SDII files can be exported or converted on import, they cannot be used within Pro Tools sessions on Windows.*

To install and configure the MacOpener demo included with Pro Tools:

- 1 Insert the Pro Tools Installer CD into your CD-ROM drive.
- 2 Locate and double-click the MacOpener installer file in the MacOpener Demo folder located at CD-drive:/Additional Files/MacOpener Demo Installer. Follow the on-screen instructions to install MacOpener. After installation is complete, restart your computer.
- 3 Choose Start > Programs > MacOpener > MacOpener Driver Preferences.
- 4 Verify that the MacOpener Driver is enabled. Under Driver Settings, select “Enable MacOpener Driver.”
- 5 Under Extension Mapping, select “Do not add the PC extension to the Mac file name.”
- 6 Click OK to quit the MacOpener Driver Preferences.

7 Choose Start > Programs > MacOpener > Mac Lic.exe. When installation is complete, close the installer.

 *All formatting and maintenance of HFS/HFS+ drives should be carried out when the drive is connected to a Macintosh.*

 *For more information about MacOpener and its performance limitations, see the Pro Tools Reference Guide.*

Installing ProControl or Control|24 Software

To install Digidesign Ethernet support for ProControl or Control|24:

- 1 On the desktop, right-click the My Network Places icon, and then choose Properties.
- 2 Right-click the relevant Local Area Connection icon, and then choose Properties.
- 3 Click Install, select Protocol, and click Add.
- 4 Click Have Disk.
- 5 Select the DigiNet.inf file in either the ProControl or Control|24 directory (on your Pro Tools Installer CD-ROM in Additional Files/Controllers/Controllers), and click OK.

The Installer installs the DigiNet.inf files in the ProControl or Control|24 directory in Digidesign/DAE/Controllers.

- 6 Click Close.

Configuring MIDI

Pro Tools for Windows uses your Multimedia Setup to configure MIDI devices and their properties. Refer to your device's documentation to properly configure the device.

Checking Your HD System

Before you launch Pro Tools, you may want to run the DigiTest diagnostic application to ensure that all TDM cards in the system are recognized, installed in the proper order, and have valid TDM FlexCable connections.

 *If you turned off Driver Signing Warning, be sure to enable it once Pro Tools hardware and software have been installed.*

Starting Up Your System

Whenever you start your system, turn on all of your system components in a specific order.

To start your Pro Tools system:

- 1 Make sure all your equipment (including your computer) is off.
- 2 For TDM systems with an expansion chassis, turn on the expansion chassis.
- 3 Turn on any external hard drives. Wait approximately ten seconds for them to spin up to speed.
- 4 Turn on any MIDI interfaces and devices, or synchronization peripherals.
- 5 Lower the volume of all output devices, then turn on your Pro Tools audio interfaces. Wait at least fifteen seconds for the audio interface to initialize and the status LEDs to stop flashing.
- 6 Turn on your computer.

Running DigiTest

DigiTest is installed with Pro Tools and resides in the following folder on your hard drive: Digidesign/Pro Tools/Pro Tools Utilities.

⚠ Before you run DigiTest, lower the volume of all output devices. Very loud digital noise may be emitted during the test.

To run DigiTest:

- 1 Quit Pro Tools if it is running.
- 2 Lower the volume of all output devices on your system.
- 3 Choose Start > Programs > Digidesign > Pro Tools > DigiTest.

DigiTest opens and lists the supported cards it finds in your system, showing their corresponding slot locations.

If you have a large number of cards or audio interfaces, it may take a while for the DigiTest window to appear, as DigiTest scans for all cards and interfaces connected to the system.

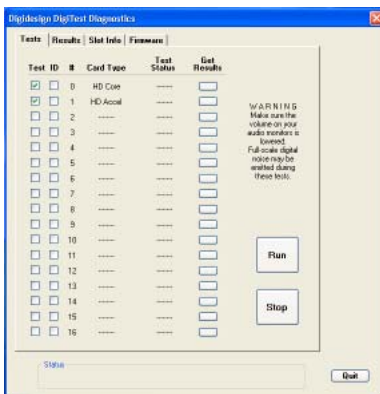

DigiTest main test window

💡 The order in which cards are listed within DigiTest may not match the actual slot locations of cards installed in your computer or expansion chassis. This is normal, and does not affect DigiTest operations in any way.

4 Select the cards in your system you want to test by selecting Test in the left hand column for each card.

5 Click Run.

If cards are not installed in the proper order, DigiTest will display error codes in the Status box of each card identified as being misconfigured.

The more cards and audio interfaces in your system, the longer the test will take.

6 When prompted, power cycle all Pro Tools peripherals in your system. Click Continue.

7 To test the interfaces connected to your system, check "Test I/O Box."

💡 LEDs on your digital interfaces may light up during this test. This is normal.

8 When the test is finished, you can view the test results by doing one of the following:

- Click the Get Results button next to a card name.
- Click the Results tab and choose a card slot from the pop-up menu.

9 In the Results page of the DigiTest window, click Show Failures Only to display failed tests for the selected card, or click Show All Results to display all test results for the selected card.

For descriptions of error codes, refer to Appendix B, "DigiTest Error Codes."

10 Click Quit to close DigiTest.

11 Restart your computer.

Errors and Undetected Cards

Complete the steps below if any of the following occur:

- DigiTest fails to launch.
- An error message has been displayed for a card in DigiTest.
- A supported card is installed but not automatically detected during DigiTest.

If a supported card is installed and is not automatically detected:

- 1 Quit DigiTest.
- 2 Turn off the entire Pro Tools system.
- 3 Reinstall the cards (see “Installing Pro Tools|HD Cards” on page 17).
- 4 Check the card seating.
- 5 Check the TDM FlexCable connections. Check the orientation of the cable from card to card (ports B to A), and check the integrity of the FlexCable connections to the cards.
- 6 Turn on the system.
- 7 Run DigiTest again.

Identifying Digidesign Cards with DigiTest

You can use DigiTest to identify which cards are in which slots in your system. This is especially useful if you have multiple Digidesign cards of the same type installed in your system.

To identify Digidesign cards with DigiTest

- 1 Quit Pro Tools if it is running.
- 2 Locate and double-click the DigiTest application on your hard drive.

DigiTest opens and lists the supported cards it finds in your system.

3 Open your computer case or expansion chassis so you can see the top edge of the cards installed in your system.

4 In the DigiTest window, select the ID check box next to a card name. The green LED near the top edge of the corresponding card flashes.

Viewing Card Information with DigiTest

DigiTest can display identifying information such as serial number, date of manufacture, and firmware ROM version, for each card in your system. This information is useful if you need to contact Digidesign Technical Support about your Pro Tools hardware.

To display information for a card in your system:

- 1 Quit Pro Tools if it is running.
- 2 Locate and double-click the DigiTest application on your hard drive.
- 3 Click the Slot Info tab.
- 4 Choose a card slot from the pop-up menu.

Updating Audio Peripheral Firmware with DigiTest

If firmware updates are available for any of your HD-series audio interfaces (192 I/O, 192 Digital I/O, 96 I/O, or 96i I/O), you can use DigiTest to perform the update. Within DigiTest, the Firmware Update page tells you the firmware version for the selected peripheral and lets you update to a newer version, if necessary.

To update the firmware in an HD-series audio interface:

- 1 Quit Pro Tools if it is running.
- 2 Locate and double-click the DigiTest application on your hard drive.
- 3 Click the Firmware tab.

4 Choose a card slot from the pop-up menu. If any HD audio interfaces are connected to the card, the Primary or Secondary options will become available in the HD Peripheral section of the Firmware page.

If any connected interfaces are not recognized, check the connections and power to each interface and click Re-Scan.

5 Under HD Peripheral, select Primary or Secondary to view the firmware version for the corresponding interface. The firmware version is displayed just below the HD Peripheral section of the Firmware page.

6 If the firmware version is not current, click Begin Update to update the firmware in the selected audio interface.

The status of the firmware update process is displayed in the status area at the bottom of the Firmware page.

7 After the update process is complete, click Quit to close DigiTest.

Launching Pro Tools

When launching Pro Tools the first time, you are prompted to enter an authorization code to validate your software.

To validate Pro Tools software:

1 Double-click the Pro Tools application, located in the Pro Tools folder, inside the DigiDesign folder.

2 Enter the authorization code in the dialog when prompted, making sure to observe any spaces, then click Validate.



The authorization code is located on the inside cover of this guide.

Configuring Pro Tools

Pro Tools System Settings

Pro Tools lets you adjust the performance of your system by changing *system settings* that affect its capacity for processing, playback, and recording.

In most cases, the default settings for your system provide optimum performance, but you may want to adjust them to accommodate large or processing-intensive Pro Tools sessions.

Voice Count

The Number of Voices setting lets you control the number of voices available on your system. For example, the default number of voices on an HD Core system is 48 voices, using one DSP (at sample rates of 44.1 kHz or 48 kHz).

 *Changing the number of voices affects DSP usage, the total number of voiceable tracks, and overall system performance.*

Depending on the current sample rate and the number of HD Core, HD Accel, and HD Process cards in your system, you will have different choices for voice count.

 *For additional information on voice count, refer to the Pro Tools Reference Guide.*

To change the Voice Count:

1 Choose Setups > Playback Engine.

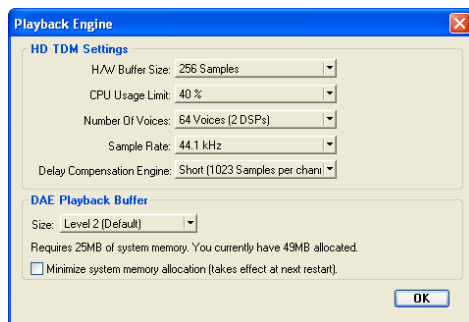

Playback Engine dialog for HD Accel system

2 Select the number of voices and DSPs to allocate for voicing by choosing a value from the Number of Voices pop-up menu.

- Select higher voice numbers when your Digidesign cards are the only PCI cards in your computer, or when you are using an expansion chassis to run higher track counts (such as 64 tracks at 96 kHz) and you want more voices per DSP (such as 16 voices per DSP at 96 kHz). These settings use fewer DSP chips for mixing (leaving more available for plug-ins) but place the highest processing load on each.
- Select medium voice numbers when your Digidesign cards are in an expansion chassis, or when you are using other PCI cards along with Digidesign cards. These settings generally provide an optimum balance between number of chips needed for voicing, and the processing load placed on each.

- Select minimum voice numbers if you are using high-bandwidth PCI cards (such as video capture cards) along with your Digidesign cards. These settings place the lightest processing load on each allocated DSP chip, but generally require more DSP chips be dedicated to voicing and mixing (leaving fewer available for plug-ins).

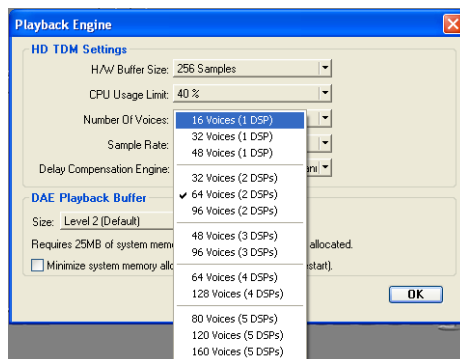

Number of Voices menu (HD Accel-equipped system)

3 Click OK.

Hardware Buffer Size

The Hardware Buffer Size (H/W Buffer Size) controls the size of the hardware cache used to handle host processing tasks such as Real-Time AudioSuite (RTAS) plug-ins.

- Lower Hardware Buffer Size settings reduce monitoring latency, and are useful when you are recording live input.
- Higher Hardware Buffer Size settings allow for more audio processing and effects, and are useful when you are mixing and using more RTAS plug-ins.

A In addition to causing slower screen response and monitoring latency, higher Hardware Buffer Size settings can affect the accuracy of plug-in automation, mute data, and timing for MIDI tracks.

To change the Hardware Buffer Size:

- 1 Choose Setups > Playback Engine.
- 2 From the H/W Buffer Size pop-up menu, select the audio buffer size, in samples.
- 3 Click OK.

CPU Usage Limit

The CPU Usage Limit controls the percentage of CPU resources allocated to Pro Tools host processing tasks such as Real-Time AudioSuite (RTAS) plug-ins.

- ◆ Lower CPU usage settings reduce how much Pro Tools processing affects other CPU-intensive tasks (such as screen redraws), and limit the amount of processor resources available for Pro Tools tasks. They are useful when you are experiencing slow system response, or when running other applications at the same time as Pro Tools.
- ◆ Higher CPU Usage Limit settings allocate more processing power to Pro Tools, and are useful for playing back large sessions or using more real-time plug-ins.

 *Increasing the CPU Usage Limit may slow down screen response on slower computers.*

To change the CPU Usage Limit:

- 1 Choose Setups > Playback Engine.
- 2 From the CPU Usage Limit pop-up menu, select the percentage of CPU processing you want to allocate to Pro Tools.
- 3 Click OK.

Delay Engine

(Pro Tools 6.4 for Pro Tools|HD Systems Only)

The Delay Engine lets you enable Delay Compensation for managing DSP delays that occur on audio tracks, Auxiliary inputs, or Master Faders because of plug-in use and mixer routing. Pro Tools maintains time-alignment between tracks that have plug-ins with differing DSP delays, tracks with different mixing paths, tracks that are split off and recombined within the mixer, and tracks with hardware inserts.

To maintain time alignment, Pro Tools adds the exact amount of delay to each track necessary to make that particular track's delay equal to the delay of the track that has the *longest* delay.

Delay Compensation should be enabled during mixing and playback for optimal delay compensated sound. In some cases when recording, Delay Compensation should be turned off.

To enable Delay Compensation:

- Choose Operations > Use Delay Compensation.

Delay Compensation Settings

There are three settings in the Playback Engine dialog for dedicating DSP resources for Delay Compensation:

None Allocates no DSP resources for automatic delay compensation.

Short Allocates minimal DSP resources of delay compensation for each channel. This is the most efficient setting for Pro Tools|HD Accel systems.

Long Allocates maximum DSP resources of delay compensation for each mixer channel. Long delay compensation uses the same DSP resources used by high DSP overhead plug-ins.

To configure the Delay Compensation Engine:

- 1 Choose Setups > Playback Engine.
- 2 From the Delay Compensation Engine pop-up menu, select a Delay compensation setting.
- 3 Click OK.

The delay compensation option will be saved as a session and system preference.

DAE Playback Buffer Size

The DAE Playback Buffer Size determines the amount of memory DAE uses to manage disk buffers, which affects system performance.

- ◆ Lower DAE Playback Buffer Size settings can improve playback and recording initiation speed. However, a lower setting can make it difficult for slower hard drives to play or record tracks reliably.
- ◆ Higher DAE Playback Buffer Size settings can allow for a higher density of edits in a session. However, a higher setting can cause a time lag to occur before playback or recording begins. It can also cause a time lag to occur when you are editing during playback.

To change the DAE Playback Buffer Size:

- 1 Choose Setups > Playback Engine.
- 2 From the DAE Playback Buffer pop-up menu, select a buffer size. Memory requirements for each setting are shown at the bottom of the Playback Engine dialog.
- 3 Click OK.

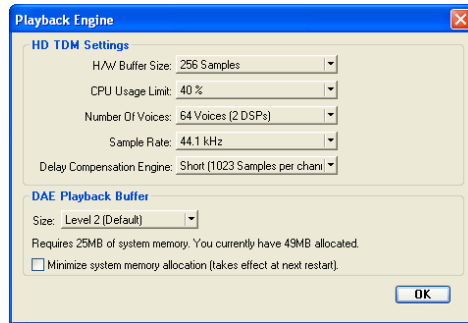

Playback Engine dialog for Pro Tools | HD Accel system

If Pro Tools needs more system memory for the DAE Playback Buffer, it will prompt you to re-start your computer.

System Memory Allocation

When you start your computer, Pro Tools automatically reserves a portion of system memory for the DAE Playback Buffer. This reserved memory is unavailable to other applications, even if Pro Tools is not running.

You can set Pro Tools to reserve only the minimum amount of required memory, so that more system memory is available to other applications.

To minimize system memory allocation:

- 1 Choose Setups > Playback Engine.
- 2 Select the “Minimize System Memory Allocation” option.
- 3 Click OK.
- 4 Restart your computer.

Pro Tools Hardware Settings

Pro Tools lets you set the default sample rate and clock source for your system, as well as a range of controls specific to each type of audio interface.)

Default Sample Rate

The Sample Rate setting appears as the default sample rate when you create a new session. (This setting is available in the Hardware Setup dialog only when no session is open.)

 You can change the sample rate when creating a new Pro Tools session by selecting a different sample rate in the New Session dialog. (See “Starting a Session” on page 75.)

To change the default Sample Rate:

- 1 Make sure that no Pro Tools session is open.
- 2 Choose Setups > Hardware Setup.

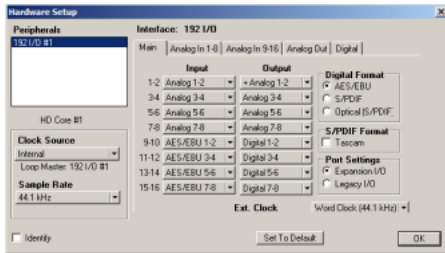

Hardware Setup dialog for 192 I/O, Main page

- 3 Choose the sample rate from the Sample Rate pop-up menu.
- 4 Click OK.

Sample Rates and Expanded Systems

With 176.4 kHz and 192 kHz sample rates, as many as four HD-series cards can be used. Any additional cards (up the total system maximum of seven cards) will switch to Inactive mode. The cards and any attached peripherals will become active again when the sample rate is set to 96 kHz or lower. See also “Offline Peripherals” on page 38.

Clock Source

The Pro Tools Hardware Setup dialog lets you select the Clock Source for the system.

Internal If you are recording an analog signal directly into Pro Tools, you will usually use the Pro Tools Internal clock source.

External If you are transferring material into Pro Tools from an external digital device, or if you utilize a common house clock signal, you will synchronize Pro Tools to that digital device or common signal. Depending on your audio interface, external options can include AES/EBU [Encl], S/PDIF, Optical [Encl], AES/EBU 1–8, TDIF, ADAT, and Word Clock. For details, refer to the *Pro Tools Reference Guide* or the guide for your audio interface.

To select the Clock Source:

- 1 Choose Setups > Hardware Setup.
- 2 Choose the clock source from the Clock Source pop-up menu.
- 3 Click OK.

 Your digital input device must be connected and powered on for Pro Tools to synchronize to it. If your input device is not powered on, leave the Clock Source set to Internal.

Configuring Audio Interfaces

Pro Tools|HD audio interfaces support 16 channels of simultaneous I/O and multiple I/O formats (including analog, AES/EBU, ADAT Optical, S/PDIF, and TDIF).

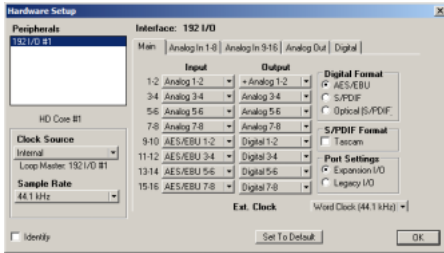

Hardware Setup dialog for 192 I/O, Main page

The Main page of the Hardware Setup dialog is where you define which physical inputs and outputs on your audio interface are routed to available inputs and outputs in Pro Tools. You can think of this window as a patchbay that allows you to route any of the inputs or outputs on your HD-series audio interfaces to channel assignments in the Pro Tools mixer.

The Main page also provides controls for defining whether Expansion Port or Legacy Port peripherals are active.

To configure the interfaces in your system, you select each interface in the Peripherals list and set the parameters for that interface.

Identifying Audio Interfaces

If you have multiple audio interfaces of the same type connected to your system, before you make audio connections to them, you should confirm the identity of each interface. This ensures that you choose the appropriate interface in the Peripherals list when you define its inputs and outputs in the Hardware Setup dialog.

To identify audio interfaces in your system:

- 1 Choose Setups > Hardware Setup.
- 2 From the Peripherals list, select an audio interface connected to your system.

 Use the Up and Down Arrow keys to scroll through the Peripherals list in the Hardware Setup dialog.

- 3 Make sure the Main page tab is chosen.
- 4 Select the Identify option, located in the lower left corner of the Hardware Setup dialog. This illuminates all the LEDs on the front panel of the selected audio interface.

5 Make a note of which interface in your studio setup corresponds to the identified interface.

- 6 Repeat the above steps for each additional audio interface in your setup.

 Legacy audio interfaces must be initialized in the Peripherals list before they can be identified. See “Configuring Legacy Audio Interfaces” on page 38.

To configure HD audio interfaces:

- 1 Choose Setups > Hardware Setup.
- 2 From the Peripherals list, select an audio interface connected to your system.
- 3 Make sure Main page tab is chosen.
- 4 From the Clock Source pop-up menu, select the appropriate clock source for the interface.
- 5 If you want to send clock output to other devices attached to the audio interface, select the appropriate output from the Ext. Clock Output pop-up menu.

If the Legacy I/O Port is enabled (and not the Expansion I/O Port) then the Ext. Clock Output automatically switches to Slave Clock (256x sample rate). To reset the Ext. Clock Output to

Word Clock, change the Port Settings back to Expansion I/O, then select the Legacy audio interface in the Peripherals list, and set it to No Interface in the Interface pop-up menu. (The 96i I/O does not support Legacy I/O.)

6 Select which digital I/O port on your audio interface enclosure is active by selecting an option under Digital Format. Depending on the type of interfaces in your system, choices include AES/EBU, S/PDIF, and Optical (S/PDIF). Selecting Optical (S/PDIF) resets the Optical I/O port (which is, by default, eight channels of ADAT Optical I/O) to two channels of S/PDIF Optical I/O. (The 96i I/O supports stereo S/PDIF RCA digital input and output only.) For more information about HD enclosure and card ports, refer to the guide for your audio interface.

7 For S/PDIF compatibility with Tascam DA-30 DAT recorders, select the Tascam option under S/PDIF Format.

8 From the Input and Output channel pop-up menus, select the physical ports (such as Analog 1–2 or Optical 1–2), that will be routed to the corresponding Pro Tools input and output channels (such as Ch 1–2, Ch 3–4), listed on the left side of the Main page. (This feature is not available with the 96i I/O.)

Inputs and outputs of similar format are differentiated in the input and output channel pop-up menus. For example, the AES/EBU inputs and outputs in the 192 I/O enclosure are listed as AES/EBU [Encl], while the AES/EBU inputs and outputs on the factory-installed Digital I/O card are listed (in pairs) as AES/EBU 1–2, AES/EBU 3–4, AES/EBU 5–6, and AES/EBU 7–8. For 192 I/Os equipped with the optional

Digital I/O Card, the additional AES/EBU I/O ports on the optional card are listed as AES/EBU 9–10, AES/EBU 11–12, AES/EBU 13–14, and AES/EBU 15–16.

 Refer to your peripheral's guide for configuration details and restrictions. For example, the Optical 1–8 channels (on the 192 I/O enclosure) will not be available at session sample rates of 88.2 kHz or higher, while the ports on the 192 I/O Digital I/O card will still be available.

9 Configure controls for your HD audio interface. See “Configuring 192 I/O and 192 Digital I/O Controls” on page 35, “Configuring 96 I/O Controls” on page 36, and “Configuring 96i I/O Controls” on page 37.

10 For additional HD-series interfaces, choose the interface in the Peripherals list, and repeat the above steps.

Configuring 192 I/O and 192 Digital I/O Controls

To configure controls for a 192 I/O:

- 1 With the 192 I/O selected in the Peripherals list, click the Analog In tab for the following options:
 - You can set your operating level on a channel-by-channel basis by selecting Reference Level +4 dBu or –10 dBV. These settings correspond to two different input connectors on the rear of the 192 I/O. Refer to the *192 I/O Guide* for more information on setting operating levels.
 - Each of the analog channels in the 192 I/O has two Input Trims, labeled A and B, for precisely calibrating and switching levels. You can select Input Trim A or B on a channel-by-channel basis. Refer to the *192 I/O Guide* for information on setting the rear panel trims.

- You can select Soft Clip on a channel-by-channel basis. The Soft Clip limiter attenuates the incoming analog signal, providing extra protection from temporary clipping transients that can cause digital distortion when they exceed the maximum input of the unit. With Soft Clip enabled, 192 I/O supports an additional 4 dB of headroom by rounding off the top 4 dB to the clip point. This is useful for eliminating stray transients or for emulating analog tape saturation.

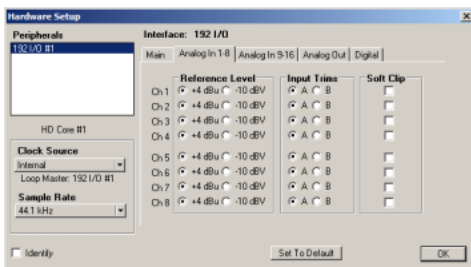

Hardware Setup dialog for 192 I/O, Analog In page

2 Click the Analog Out tab for the following option:

- Each of the analog channels in the 192 I/O has two Output Trims, labeled A and B, respectively. You can select Output Trim A or B on a channel-by-channel basis.

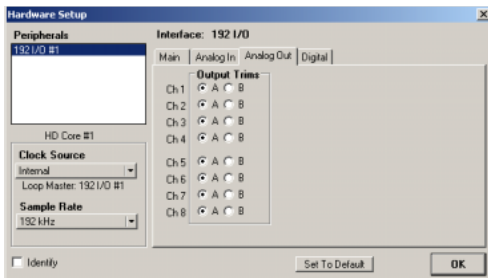

Hardware Setup dialog for 192 I/O, Analog Out page

To configure controls for a 192 Digital I/O or 192 I/O with an optional Digital I/O card:

- On the 192 Digital I/O or a 192 I/O with an optional Digital I/O card, click the Digital tab to set the Input Format (AES/EBU, TDIF, or ADAT Optical) and enable real-time sample rate conversion (in channel pairs, with the SR Conversion option).



At session sample rates above 48 kHz, sample rate conversion for the TDIF and Optical (ADAT) inputs on the Digital I/O card is automatically enabled on all eight inputs of the selected format.

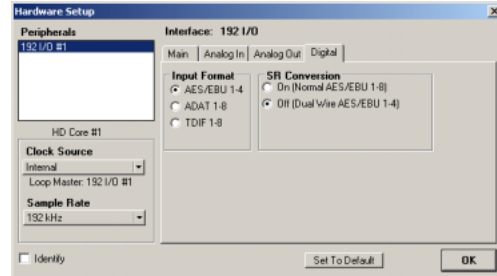

Hardware Setup dialog for 192 I/O, Digital page

Configuring 96 I/O Controls

To configure controls for a 96 I/O:

- With the 96 I/O selected in the Peripherals list, configure your I/O front panel meters for input or output metering from the Meters pop-up.
- Click the Analog In tab for the following option:

- You can set your operating level on a channel-by-channel basis by selecting Reference Level +4 dBu or -10 dBV. Refer to the *96 I/O Guide* for more information on setting operating levels.

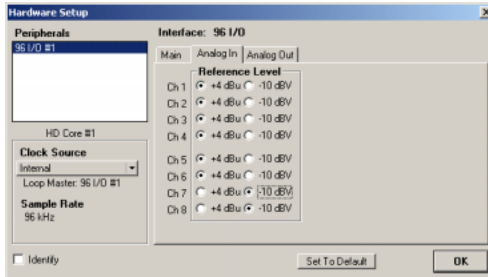

Hardware Setup dialog for 96 I/O, Analog In page

3 Click the Analog Out tab for the following option:

- You can set your output level on a channel-by-channel basis by selecting Reference Level +4 dBu or -10 dBV. Refer to the *96 I/O Guide* for more information on setting operating levels.

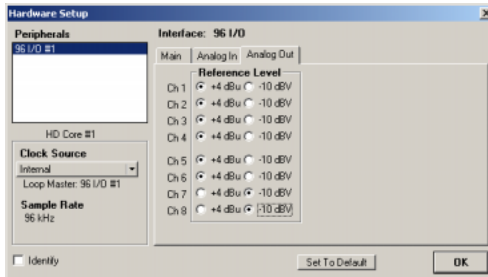

Hardware Setup dialog for 96 I/O, Analog Out page

Configuring 96i I/O Controls

To configure controls for a 96i I/O:

- With the 96i I/O selected in the Peripherals list, configure your I/O front panel meters for input or output metering from the Meters pop-up.
- Set input sensitivity by doing the following:
 - For Inputs 1–4, set the input trim slider to match the output level of the connected instrument. Choices range from -12 dBV to +4 dBu. If you do not know the output level of the device, use the default input trim level, then fine tune the input level sensitivity.
 - For each input 5–16 being used, select -8 dBV or +4 dBu as appropriate to best match the output level of the connected instrument.
- Set Output levels (select -10 dBV or +4 dBu).
- Click Done.

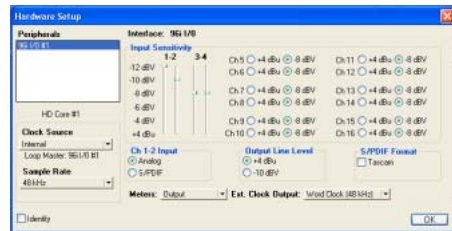

Hardware Setup for 96i I/O

You can select analog or digital input as sources for 96i I/O channels 1–2. Only channels 1–2 can access the S/PDIF inputs.

To select analog or digital input for channels 1-2:

- 1 Choose Hardware > Setup, and select 96i I/O in the Peripherals list to display the 96i I/O window.
- 2 Click to set Ch 1–2 Input to Analog or S/PDIF, as appropriate.

 *The 96i I/O only supports analog and digital switching for channels 1–2, and only from within the Hardware Setup and I/O Setup dialogs. The 96i I/O does not support path remapping within I/O Setup.*

Configuring Legacy Audio Interfaces

Before you can configure a Legacy audio interface, it must first be initialized in Hardware Setup.

To initialize a Legacy audio interface:

- 1 Make sure to lower the volume of your output devices. Very loud digital noise may be emitted before the Legacy audio interface is initialized.
- 2 Turn on your Legacy audio interface.
- 3 From the Peripherals list, choose the primary audio interface (the interface to which your Legacy audio interface is connected).
- 4 In the Main page of the Hardware Setup dialog, select the Legacy I/O option under Port Settings.
- 5 In the Peripherals list, “No Interface” is listed twice, directly below the primary audio interface. Click the first “No Interface.” An Interface pop-menu appears in the Hardware Setup dialog, listing supported I/O choices.
- 6 From the Interface pop-up, select the type of Legacy audio interface you connected. (If your Legacy interface does not appear, check connections and repeat from step 1, above. See also “Offline Peripherals” on page 38.)

After you select the type of Legacy audio interface, the Main page updates with controls that can be configured.

- 7 Repeat the above steps for each additional Legacy audio interface.

 *For more information on Hardware Setup controls for each I/O, refer to its guide.*

Offline Peripherals

When a Legacy audio interface and HD peripheral are connected to your primary HD peripheral, only one can be online at a time. An offline peripheral is indicated by brackets in the Peripherals List of the Hardware Setup dialog. For example, if you have a 96 I/O and an 882|20 connected to a 192 I/O, and the 96 I/O is offline, it will appear in the Peripherals List as “[96 I/O].”

Peripherals will also go offline if they audio interface or card to which they are attached is made inactive. See “Sample Rates and Expanded Systems” on page 33 for more information.

Configuring I/O Setup

The I/O Setup dialog provides a graphical representation of the signal routing for each connected audio interface, with controls to route physical ports to Pro Tools inputs and outputs. These controls mirror the routing controls found in the Hardware Setup dialog—changes made to physical routing in one dialog are always reflected in the other. The I/O Setup dialog also lets you label and map Pro Tools input, output, insert, and bus *signal paths*.

Pro Tools comes with default I/O Setup settings that will get you started. You only need to go to I/O Setup if you want to remap or rename the default I/O paths or if you change your system hardware (for example, adding an expansion card to a 192 I/O).

 Refer to the *Pro Tools Reference Guide* for more information on setting up I/O paths.

To configure I/O routing in I/O Setup:

- 1 Choose Setups > I/O Setup.
- 2 Click the Input or Output tab to display the corresponding connections.
- 3 To change the name of a path or subpath, double-click directly on the Path Name, type a new name for the path, and press Enter.
- 4 To change the destination of an Input or Output path or subpath, click directly on an Input or Output Selector for an interface channel pair, just below an audio interface icon. (This feature is not available for the 96i I/O.)
- 5 From the pop-up menu, select a physical port pair (such as Analog 1–2), to route to the corresponding Pro Tools channel pair (such as A 1–2) in the Path Name column on the left.
- 6 Repeat the above steps for additional channel pairs.
- 7 Click OK.

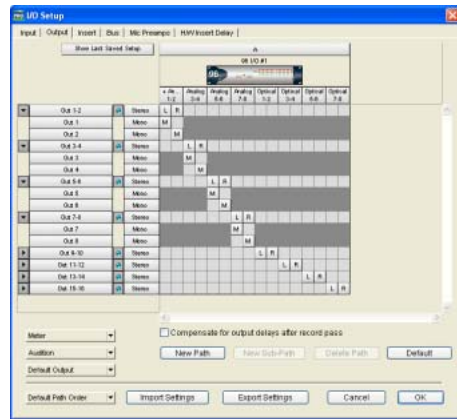

I/O Setup dialog

Routing a Pro Tools Output Pair to Multiple Destinations

Pro Tools channel pairs can be routed to multiple outputs on your Digidesign audio interface through the Hardware Setup dialog.

For example, if Pro Tools Outputs 1–2 are assigned to both Analog 1–2 and Digital 1–2, that signal will be routed simultaneously to both pairs of output ports on your audio interface.

This lets you send the same signal (such as a stereo pair, a stem mix, or a multichannel mix) to multiple destinations (such as multiple mastering devices).

To route a Pro Tools output channel pair to multiple audio interface output ports:

- 1 Choose Setups > Hardware Setup.
- 2 From the Peripherals list, select an interface.
- 3 Click the Main tab.
- 4 Select an output pair from an Output pop-up menu.
- 5 Start-click the same pop-up menu and choose an additional output pair.

The output name updates with a plus sign (“+”) before it to indicate that multiple output ports are selected. In the pop-up menu, each physical port pair assigned to that Pro Tools output pair is indicated by a check mark.

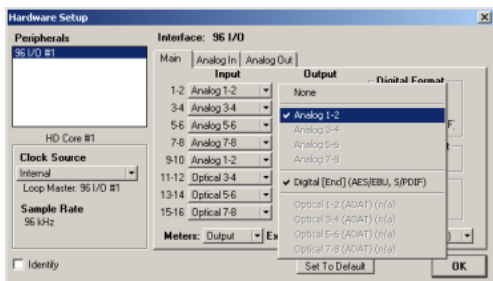

Hardware Setup dialog for 96 I/O, Main page

- 6 Repeat the above steps to select additional output destinations. The only limit to output choices is the number of outputs available in your system.

chapter 3

Macintosh Configuration

Installation of a Pro Tools|HD-series system on a Macintosh computer includes the following steps:

- 1 Install Pro Tools hardware. (See “Installing Pro Tools Hardware” on page 43.)
- 2 Configure Apple System Software settings. (See “Apple System Settings” on page 52.)
- 3 Install Pro Tools TDM software. (See “Installing Pro Tools Software” on page 52.)
- 4 Check your Pro Tools system. (See “Checking Your HD System” on page 54.)
- 5 Configure your Pro Tools system. (See “Configuring Pro Tools” on page 57.)

Pro Tools Hardware Overview

The number of Pro Tools TDM cards in your system will differ depending on your system configuration. Card components for each configuration are listed below.

 *If you are using an Expansion Chassis to increase the number of cards in your system, refer to the Expanded Systems Guide included with your Pro Tools system.*

Pro Tools|HD Hardware

Pro Tools|HD hardware is available in the following configurations:

Pro Tools|HD 1 Includes a single HD Core card

Pro Tools|HD 2 Accel Includes an HD Core card, an HD Accel card, and a TDM FlexCable for connecting the HD Core to the HD Accel card

Pro Tools|HD 3 Accel Includes an HD Core card, two HD Accel cards, and two TDM FlexCables for connecting the cards to each other



Additional HD Accel and HD Process cards may be added to expand your Pro Tools system. HD Accel cards are fully compatible with HD Process cards. Up to seven HD cards are supported in a single Pro Tools|HD system.

HD Core Card

All Pro Tools|HD systems include an HD Core card. The HD Core card is the only Pro Tools|HD card that does not require the presence of any other HD-series cards. (Pro Tools|HD 1 systems are comprised of a single HD Core card).

The HD Core card provides up to 96 tracks of direct-to-disk recording and playback, as well as DSP power for mixing and plug-in processing. The HD Core card supports up to 24-bit and up to 192 kHz sessions.

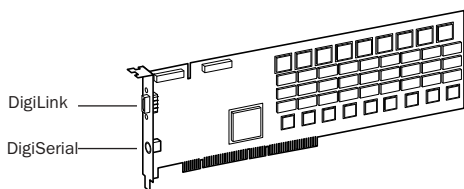

HD Core card

The HD Core card includes a single DigiLink port for connecting up to 32 channels of audio input and output to your Pro Tools|HD system.

The DigiSerial port on the HD Core card is for connecting a Digidesign SYNC I/O. This connector is an 8-pin mini-DIN.

⚠ *The DigiSerial port on HD Core cards does not support MachineControl connections, nor does it support the Digidesign Universal Slave Driver (USD).*

⚠ *If your HD Core card has two DigiSerial ports, use the DigiSerial port closest to the DigiLink connector.*

HD Accel Card

The HD Accel card is included in Pro Tools|HD 2 Accel and Pro Tools|HD 3 Accel systems. The HD Accel card is an expansion card, and requires the presence of at least one HD Core card.

The HD Accel card provides up to 32 additional tracks of direct-to-disk recording and playback, as well as DSP power for mixing and plug-in processing. The HD Accel card supports up to 24-bit and up to 192 kHz sessions.

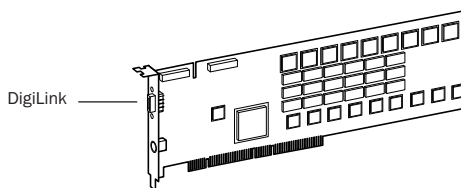

HD Accel card

The HD Accel card includes a single DigiLink port for connecting up to 32 channels of audio input and output to your Pro Tools|HD system.

The DigiSerial port on the HD Accel card does not offer any functionality.

HD Process Card

The HD Process card is the predecessor to the HD Accel card. Like HD Accel cards, HD Process cards are expansion cards, requiring at least one HD Core card.

💡 *HD Process cards are fully compatible with HD Accel cards and HD Core cards in expanded Pro Tools|HD systems.*

The HD Process card provides up to 32 additional tracks of direct-to-disk recording and playback (up to a maximum of 128 tracks in systems without an HD Accel card), as well as DSP power for mixing and plug-in processing. The HD Process card supports up to 24-bit and up to 192 kHz sessions.

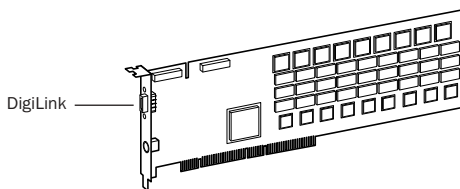

HD Process card

The HD Process card includes a single DigiLink port for connecting up to 32 additional channels of audio input and output to your Pro Tools|HD system (up to a maximum of 96 channels).

The DigiSerial port on an HD Process card does not offer any functionality

TDM FlexCable

The TDM FlexCable is used to connect a pair of cards in your Pro Tools system so they can share data along the TDM bus. Additional FlexCables are required to connect additional cards. One FlexCable comes with each HD Accel card.

! *The TDM FlexCable is a flexible printed circuit board with delicate traces. Do not overbend, twist, or pinch the cable. Doing so may cause unpredictable behavior in Pro Tools as well as harm to your system.*

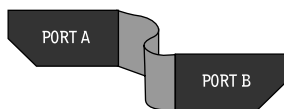

TDM FlexCable

Installing Pro Tools Hardware

To install HD-series hardware, you first install Pro Tools|HD cards, then for systems with more than one card, connect the cards with a TDM FlexCable.

Installing the Pro Tools|HD Cards

This section shows how to install Pro Tools|HD cards into a Macintosh computer. To install cards into an expansion chassis, see the *Expanded Systems Guide*.

To install Pro Tools cards:

- 1 Turn off your computer and any peripherals. Leave your computer's power cable plugged in so the computer is grounded.
- 2 Wait 5–10 minutes to allow the computer's internal components to cool down to avoid burning yourself.
- 3 Disconnect all cables attached to the computer (such as hard drives, displays, USB and FireWire devices) except for the power cable.
- 4 To prevent damaging sensitive electronics, discharge any static electricity that may be on your clothes or body by touching a grounded metal surface, such as the metal PCI access covers on the back of the computer.
- 5 Disconnect the power cord from the computer.
- 6 Open the computer case.
- 7 Remove the metal access port cover behind the PCI slot you want to use by removing the screw and sliding the cover out from the access port.

8 Install the HD Core card into the lowest-numbered PCI slot in the computer based on your computer model, as follows:

Power Mac G5 The Power Mac G5 has three PCI slots (named PCI slot 2, 3, and 4). PCI slot numbers increase from *bottom to top* as you face the open computer case from the front. Install the HD Core card into PCI slot 2.

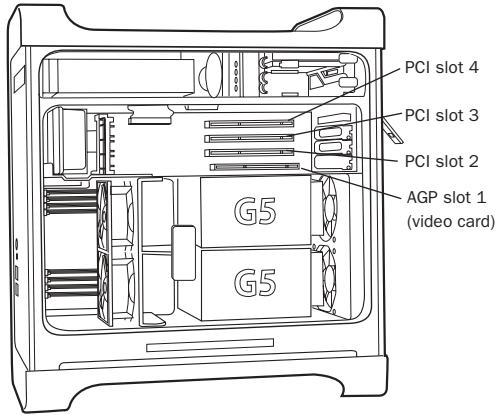
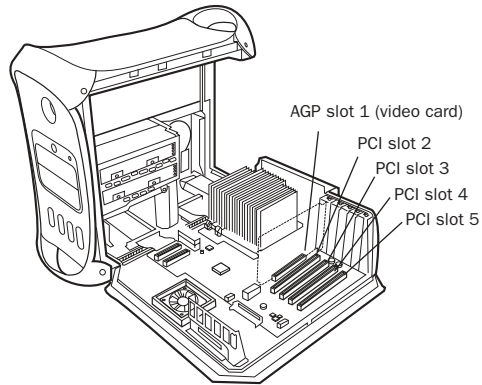

Figure 3. Power Mac G5

Power Macintosh “Mirrored Door” G4 The Power Macintosh “Mirrored Door” G4 has reflective drive bay doors and four holes across the front. Its PCI slot numbers increase from *left to right* as you face the open computer case from the front.

Note that the PCI slot numbering in the newer “Mirrored Door” G4 computer runs in the opposite direction of previous G4 models.

⚠ Be very careful when opening or closing the case of a “Mirrored Door” G4 computer. Any PCI cards installed in the higher-numbered slots may be damaged if they touch the top of the computer case.



Power Macintosh “Mirrored Door” Dual Processor G4

Power Macintosh “QuickSilver” G4 The Power Macintosh “QuickSilver” and earlier G4 models have a single speaker grille or hole on the front. Their PCI slot numbers increase from *right to left* as you face the open computer case from the front.

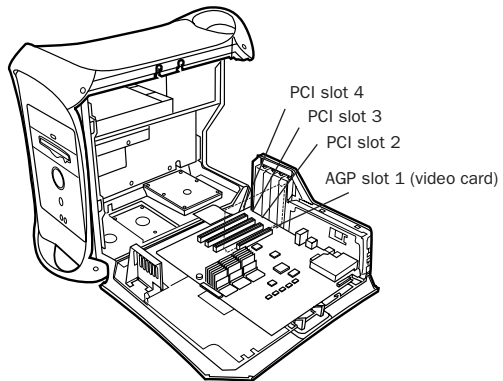

Power Macintosh “QuickSilver” Dual Processor G4

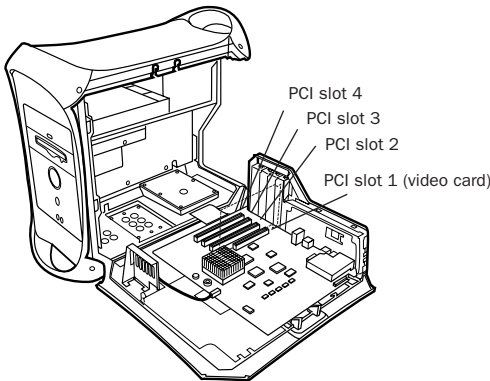

Power Macintosh Single Processor G4

9 If you are installing additional Pro Tools|HD cards, skip to the next step,

– or –

If you have no additional cards to install, do the following:

- Secure the card in place with the screw you removed earlier, and close the computer.
- Skip to “Connecting Audio Interfaces” on page 48.

10 Install the first HD Accel card (if any) in the second PCI slot (PCI slot 3).

11 Install any remaining HD Accel cards in the remaining consecutive PCI slots.

12 Install any HD Process cards (if any) in the remaining consecutive PCI slots.

13 If you are installing a SCSI host bus adapter (HBA) card, install it in the highest-numbered remaining slot.

⚠ *Do not use SampleCell hardware cards in a Pro Tools|HD system.*

Check to be sure that your cards are installed in the following order, starting with the lowest numeric slot:

- Display card for your computer monitor
- HD Core card
- HD Accel cards
- HD Process cards
- Digidesign-approved video capture card
- SCSI host bus adapter (HBA) card

 *The above guidelines may include optional cards not present in your system.*

14 Secure each card in place with the slot access port screws you removed earlier.

Connecting Pro Tools|HD Cards

If you are installing a Pro Tools|HD 2 Accel, HD 3 Accel, or an expanded HD system, connect the HD cards with TDM FlexCables.

Each HD card has two ports along the top of the card, labeled *Port A* and *Port B*. The FlexCable has two connectors, also labeled *Port A* and *Port B*, to ensure proper connection. Data communication across multiple HD cards is achieved by connecting *Port B* of the first card to *Port A* of the next card with a TDM FlexCable.

 *The first FlexCable always goes from Port B on the HD Core card to Port A on the Accel or Process card, as described in the following steps.*

The PCI slot numbering in your computer determines whether you will be working right-to-left, or left-to-right when connecting cards. Refer to the instructions below for your model of computer.

To connect HD cards with the TDM FlexCable on the Power Mac G5:

1 Shape the FlexCable before installing it on your HD cards by grasping the cable with both hands with its printed side facing you, and moving the Port B portion of the cable away from you and outwards, as shown below. Do not bend the cable more than you need to, as you may damage the traces in the cable.

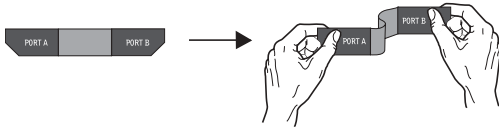

Preparing TDM FlexCable for installation

2 Turn the cable on its side, so that the connectors are facing downwards, and Port A is the higher side.

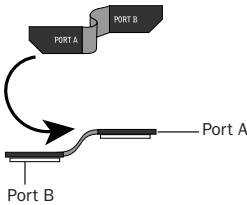

Orienting the FlexCable

3 Slide the FlexCable into the notch of the *second* card, so that the Port B connector of the FlexCable can be aligned with Port B of the first card; and the Port A connector of the FlexCable can be aligned with Port A of the second card as shown below.

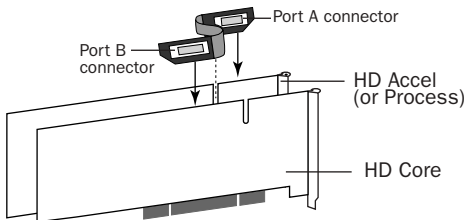

Inserting TDM FlexCable

4 Connect the Port A connector of the FlexCable to Port A on the second card. Push down gently but firmly until the cable is fully connected to the card. Attach the other end of the FlexCable (labeled Port B) to Port B on the first card.

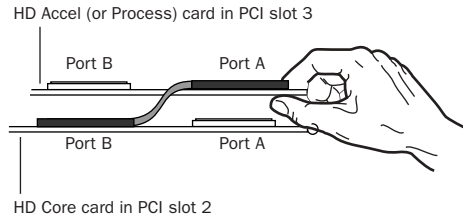

Top view of two HD cards connected with TDM FlexCable

5 Verify the connection. Make sure the FlexCable ports seat flat against the sockets on the HD cards, and are firmly attached.

6 For systems with more than two cards, connect each additional card to its preceding card. Use FlexCables to connect card pairs together, as described above, until all cards are connected. Each HD Accel or HD Process card is packaged with a FlexCable.

7 Close the computer case.

8 Proceed to “Connecting Audio Interfaces” on page 48.

To connect HD cards with the TDM FlexCable on the Power Macintosh “Mirrored Door” G4:

1 Shape the FlexCable before installing it on your HD cards by grasping the cable with both hands and moving the Port B portion of the cable straight towards you and inwards, as shown below. Do not bend the cable more than you need to, as you may damage the traces in the cable.

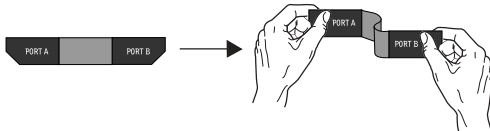

Preparing TDM FlexCable for installation

2 Slide the FlexCable into the notch of the *first* card, so that the Port B connector of the FlexCable can be aligned with Port B of the first card; and the Port A connector of the FlexCable can be aligned with Port A of the second card, as shown below.

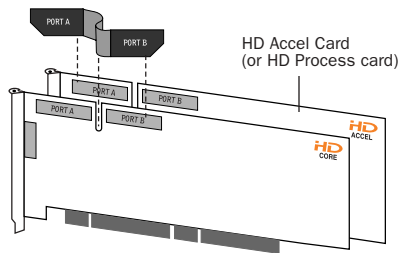

Inserting TDM FlexCable

3 Connect the Port A connector of the FlexCable to Port A on the second card. Push down gently but firmly until the cable is fully connected to the card. Attach the other end of the FlexCable (labeled Port B) to Port B on the first card.

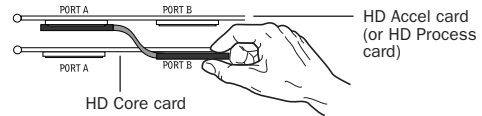

Top view of two HD cards connected with TDM FlexCable

4 Verify the connection, as shown below (orientation may be different depending on your type of CPU or chassis).

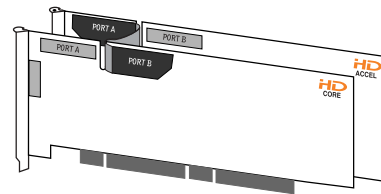

Side view of two HD cards connected with TDM FlexCable

5 For systems with more than two cards, connect each additional card to its preceding card. Use FlexCables to connect card pairs together, as described above, until all cards are connected. (Each HD Accel card is packaged with a FlexCable.)

6 Close the computer case.

7 Proceed to “Connecting Audio Interfaces” on page 48.

To connect HD cards with the TDM FlexCable on Power Macintosh “QuickSilver” and earlier G4 computers:

1 Shape the FlexCable before installing it on your HD cards by grasping the cable with both hands and moving the Port A portion of the cable straight towards you and inwards, as shown below. Do not bend the cable more than you need to, as you may damage the traces in the cable.

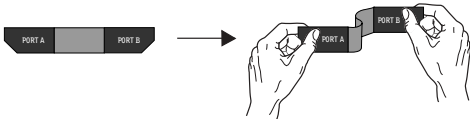

Preparing TDM FlexCable for installation

2 Slide the FlexCable into the notch of the *second* card, so that the Port B connector of the FlexCable can be aligned with Port B of the first card; and the Port A connector of the FlexCable can be aligned with Port A of the second card, as shown below.

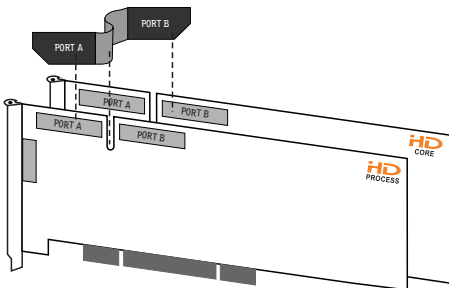

Inserting TDM FlexCable

3 Connect the Port A connector of the FlexCable to Port A on the second card. Push down gently but firmly until the cable is fully connected to the card. Next, attach the other end of the FlexCable (labeled Port B) to Port B on the first card.

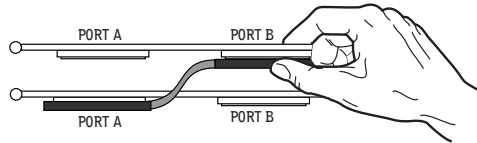

Top view of two HD cards connected with TDM FlexCable

4 Verify the connection, as shown below.

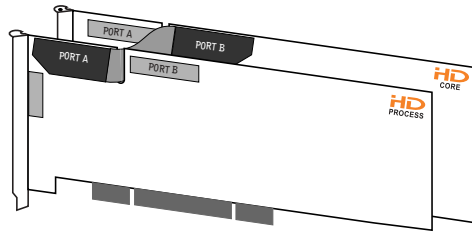

Side view of two HD cards connected with TDM FlexCable

5 For systems with more than two cards, connect each additional card to its preceding card. Use FlexCables to connect card pairs together, as described above, until all cards are connected. (Each HD Accel card is packaged with a FlexCable.)

6 Close the computer case.

Connecting Audio Interfaces

Each Pro Tools|HD-series audio interface supplies up to 16 channels of input and output to your system. Audio interfaces are connected directly to Pro Tools|HD cards, or through the Expansion ports on other HD-series interfaces.

Each HD card supports up to 32 channels. To get a full 32 channels of I/O from one card, you can connect, or *daisy-chain*, a second 16-channel HD I/O to the first HD I/O that is connected directly to the HD card.

Pro Tools|HD supports up to a maximum of eight 192 I/Os, 192 Digital I/Os, or 96 I/Os. Up to four 96i I/Os can be used simultaneously.

For examples of connecting multiple HD I/Os, see Figure 4 and Figure 5 on page 50.

⚠ *HD audio interfaces need room at their sides to maintain proper air flow for cooling. It is important to leave room for air intake and ventilation on the sides of the unit. Do not block the sides of the unit or disconnect the internal fan. If the units are rack-mounted in a case, remove the case lids or doors before operating the system. Failure to do so can result in the units overheating very quickly, which can permanently damage sensitive components.*

Legacy audio interfaces can also be connected to the 192 I/O, 192 Digital I/O, or 96 I/O (the 96i I/O does not support Legacy interfaces). These include: 888|24 I/O, 882|20 I/O, 1622 I/O, 24-bit ADAT Bridge I/O, and the original ADAT Bridge I/O. The original 888 I/O and 882 I/O interfaces are not supported with Pro Tools|HD.

To connect HD audio interfaces:

1 If you are using a single 192 I/O, 192 Digital I/O, 96 I/O, or 96i I/O, connect its Primary Port to the HD Core card with the DigiLink cable provided with the HD Core card. You must attach at least one 192 I/O, 192 Digital I/O, 96 I/O, or 96i I/O to your system in order for Pro Tools to launch.

⚠ *If you have at least one 192 I/O or 192 Digital I/O in your system configuration, it must be connected to the HD Core card as the primary interface.*

2 Connect additional HD audio interfaces to subsequent Digidesign audio cards, or daisy-chain your I/Os (by connecting the Primary Port of the secondary I/O to the Expansion Port of the primary I/O).

If you are connecting both 192 I/O (or 192 Digital I/O) and 96 I/O audio interfaces to your system, connect the 192 I/O (or 192 Digital I/O) to your HD Core card, followed by any additional 192 I/O (or 192 Digital I/O) interfaces connected to the next highest-priority cards. Then connect 96 I/O interfaces to subsequent cards, or to other interfaces, then connect 96i I/O interfaces.

You can also connect a single HD I/O to each HD card in your system using the provided DigiLink cables. (However, there is no advantage to this configuration over daisy-chaining I/Os.)

3 If you are using two or more HD audio interfaces, connect the Loop Sync Out of each interface to the Loop Sync In of the next interface with the BNC cables included in your HD I/O packaging. Then, connect the Loop Sync Out of the last interface to the Loop Sync In of the primary interface.

4 If you are connecting a Digidesign Legacy audio interface (such as an 888|24 I/O, 882|20 I/O, 1622 I/O, or Digidesign ADAT Bridge I/O), continue with “Connecting an Additional 16 Channels of Audio with Legacy Audio Interfaces” on page 51. (The 96i I/O does not support Legacy interfaces.)

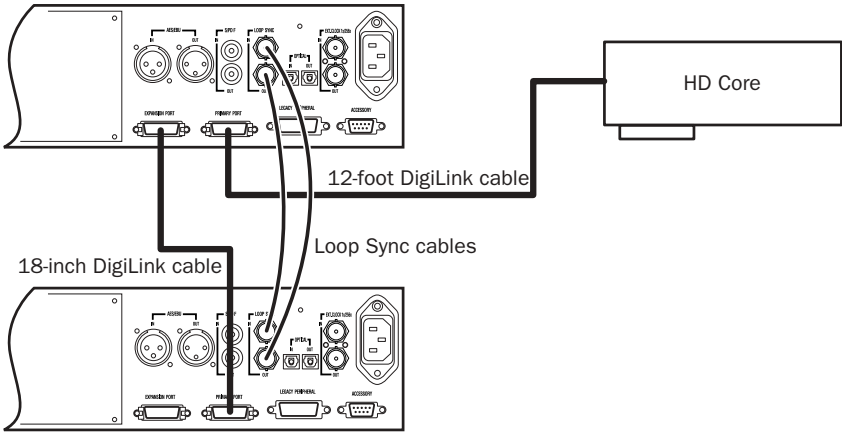

Figure 4. Two 96 I/Os (32-channel system)

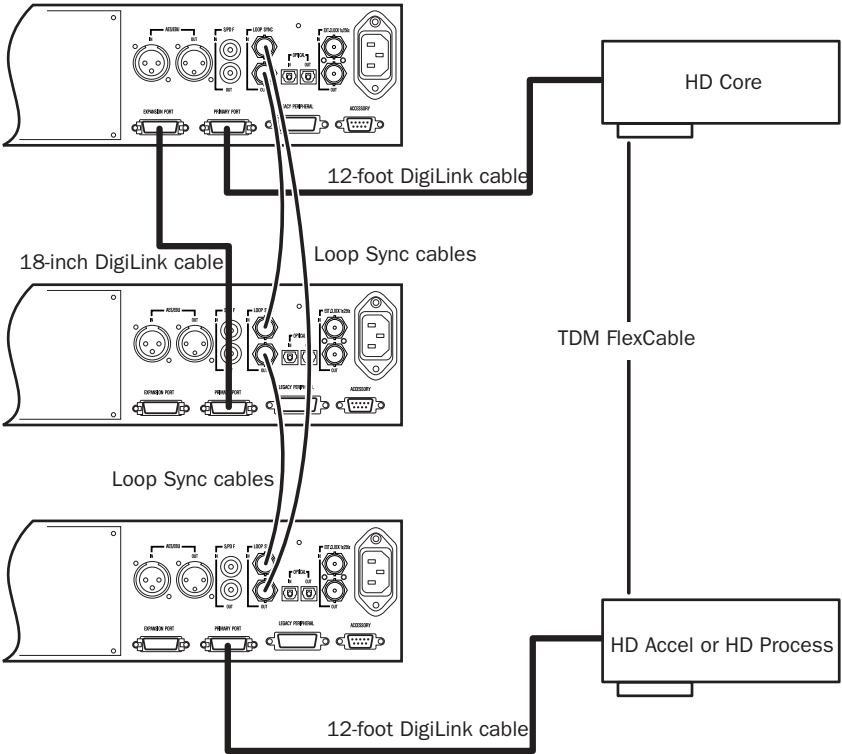

Figure 5. Three 96 I/Os (48-channel system)

Connecting an Additional 16 Channels of Audio with Legacy Audio Interfaces

Each 192 I/O, 192 Digital I/O, and 96 I/O can support 16 channels of audio to and from Digidesign Legacy I/Os. (The 96i I/O does not support Legacy I/O.) These include the 888|24 I/O, 882|20 I/O, 1622 I/O, 24-bit ADAT Bridge I/O, and the original ADAT Bridge I/O. The original 888 I/O and 882 I/O interfaces are not supported with Pro Tools|HD.

To connect Digidesign Legacy audio interfaces:

1 Connect the “MIX card” end of the peripheral cable that came with your Legacy audio interface (60-pin side) to the Legacy Port on the primary HD audio interface. Connect the other end to the Computer Port on the Legacy audio interface.

2 Connect any additional Legacy audio interfaces in the same manner, to HD audio interfaces connected directly to HD cards.

– or –

If you are using a Y cable (Legacy 16-channel peripheral cable adapter), connect this to the Legacy port first, then connect the audio interface peripheral cables to Port A and Port B of the Y cable.

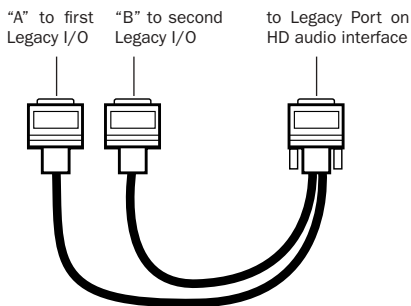



Optional 16-channel peripheral cable adapter

3 To properly clock the Legacy audio interface, connect the Ext. Clock Out port on the HD I/O to the Slave Clock In on the Legacy audio interface. The Legacy audio interface will switch to Slave mode once the proper clock is outputting from the HD I/O. Always use the Ext. Clock Out port of the same I/O to which the Legacy audio interface is attached.

If you are using the Y cable to connect multiple MIX-series audio interfaces, you must also connect the Slave Clock Out of the first Legacy interface to the Slave Clock In of the second Legacy interface with the provided BNC cable. You cannot clock more than two MIX-series audio interfaces from a single HD-series audio interface. If you have a third MIX-series audio interface, supply its 256x clock from the HD I/O to which its 60-pin cable is attached (either your second audio interface, or directly to an HD Accel or HD Process card).

You cannot slave more than two MIX-series audio interfaces to a single HD-series audio interface. If you have a third MIX-series audio interface, supply its 256x clock from the HD I/O to which its 60-pin cable is attached.

 *To ensure the proper functioning of Legacy audio interfaces (such as an 888|24 I/O or 882|20 I/O), launch Pro Tools and declare the legacy audio interfaces in the Hardware Setup dialog before turning them on. Then quit Pro Tools, shut down your computer, turn on your audio interfaces, and turn on your computer.*

 *Before you turn on and configure your Legacy audio interface, turn down the volume of output devices. Very loud digital noise may be emitted before the Legacy audio interface is initialized.*

Apple System Settings

To ensure optimum performance with Pro Tools, configure the following settings for your version of Mac OS before you install Pro Tools software.

System Settings for Mac OS X

The following settings ensure optimum performance and compatibility for systems running Mac OS X.

 *Do not use the Mac OS X automatic Software Update feature, as it may upgrade your system to a version of Mac OS that has not yet been qualified for Pro Tools. For details on qualified versions of Mac OS, refer to the latest compatibility information on the Digidesign Web site (www.digidesign.com).*

To configure Mac OS X for Pro Tools:

- 1 Turn on your computer.
- 2 Make sure you are logged in as an Administrator for the account where you want to install Pro Tools. For details on Administrator privileges in Mac OS X, refer to your Apple OS X documentation.
- 3 Choose System Preferences from the Apple Menu and click Energy Saver.
- 4 Click the Sleep tab and turn off the Energy Saver feature by setting the sleep feature to Never.
- 5 Return to the System Preferences and click Software Update.
- 6 Deselect “Automatically check for updates when you have a network connection.”
- 7 Close the Software Update dialog.

Installing Pro Tools Software

After the Apple System software settings are configured, you’re ready to install Pro Tools.

Installing Pro Tools on Mac OS X

To install Pro Tools on Mac OS X:

- 1 Make sure you are logged in as an Administrator for the account where you want to install Pro Tools. For details on Administrator privileges in Mac OS X, refer to your Apple OS X documentation.
- 2 Insert the Pro Tools Installer CD-ROM in your CD-ROM drive. Double-click “Install Pro Tools.”
- 3 Enter your Mac OS X Administrator password and click OK to authenticate the installation.
- 4 Select the Pro Tools Installer. You can also select from a list of optional items to install along with Pro Tools. Click the information button next to each item for a description of its contents.
- 5 Click Install.
- 6 Select your work environment. This loads an initial set of Pro Tools Preferences that include some of the more popular settings for post production, audio, or audio with MIDI.



Preference settings can be customized at any time in Pro Tools. See the Pro Tools Reference Guide for more information about Preferences.

7 Select whether to install the Surround Mixer plug-in. This plug-in is required for mixing, mastering, and monitoring in surround:

- Select “Yes – Monitoring in Standard Pro Tools (Film Format)” if your monitoring is configured for Film Format surround.
- Select “Yes – Monitoring in ProControl (DTS Format)” if you are using a ProControl dedicated controller.
- Select “No – Stereo mixing only” if your monitoring is configured for Stereo.



You can install the Surround Mixer plug-ins in Pro Tools at any time to enable multi-channel mixing for surround sound.

8 Click Continue.

9 When installation is complete, click Restart.

– or –

Click Continue to install any additional software or documentation, and restart your computer when you are finished.

If you plan to use any MIDI devices with Pro Tools, configure your MIDI setup with the Apple Audio MIDI Setup (AMS) utility. See Appendix G, “Configuring AMS (Mac OS X Only).”

Removing Pro Tools

If you need to remove Pro Tools from your computer, you can use the Installer CD-ROM.

To remove Pro Tools from your computer:

1 Make sure you are logged in as an Administrator for the account where Pro Tools is installed. For details on Administrator privileges in Mac OS X, refer to your Apple OS X documentation.

2 Insert the Pro Tools Installer CD-ROM in your CD-ROM drive. Double-click “Install Pro Tools.”

3 Enter your Administrator password and click OK to authenticate the installation.

4 In the Installer window, choose Uninstall from the pop-up menu, and click Uninstall.

5 Click Quit to close the Installer window.

Installing the Demo Session

(Optional)

The Pro Tools Installer CD-ROM includes a demo session that you can use to verify that your system is working.

To install a demo session:

1 Insert the Pro Tools Installer CD in your CD-ROM drive. Locate and double-click the demo session installer icon.

2 Select the demo session.

3 Set the install location to your audio drive, and click Install.

4 When installation is complete, click Quit.

Checking Your HD System

Before you launch Pro Tools, you may want to run the DigiTest diagnostic application to ensure that all TDM cards in the system are recognized, installed in the proper order, and have valid TDM FlexCable connections.

Starting Up Your System

Whenever you start your system, turn on all of your system components in a specific order.

To start your Pro Tools system:

- 1 Make sure all your equipment (including your computer) is off.
- 2 For TDM systems with an expansion chassis, turn on the expansion chassis.
- 3 Turn on external hard drives, if any. Wait approximately ten seconds for them to spin up to speed.
- 4 Turn on any MIDI interfaces and devices, or synchronization peripherals.
- 5 Lower the volume of all output devices, then turn on your Pro Tools audio interfaces. Wait at least fifteen seconds for the audio interfaces to initialize and the status LEDs to stop flashing.
- 6 Turn on your computer.

Running DigiTest

DigiTest is installed with Pro Tools and resides in the Applications folder on your hard drive, in the following location:

Digidesign/Pro Tools/Pro Tools Utilities.

⚠ Before you run DigiTest, lower the volume of all output devices. Very loud digital noise may be emitted during the test.

To run DigiTest:

- 1 Quit Pro Tools if it is running.
- 2 Lower the volume of all output devices on your system.
- 3 Locate and double-click the DigiTest application on your hard drive.

DigiTest opens and lists the supported cards it finds in your system, showing their corresponding slot locations.

If you have a large number of cards or audio interfaces, it may take a while for the DigiTest window to appear, as DigiTest scans for all cards and interfaces connected to the system.

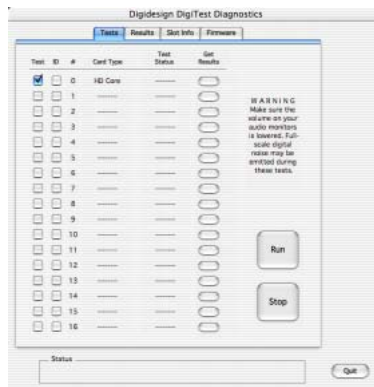

DigiTest main test window



The order in which cards are listed within DigiTest may not match the actual slot locations of cards installed in your computer or expansion chassis. This is normal, and does not affect DigiTest operations in any way.

4 Select the cards in your system you want to test by selecting Test in the left hand column for each card.

5 Click Run.

If cards are not installed in the proper order, DigiTest will display error codes in the Status box of each card identified as being misconfigured.

The more cards and audio interfaces in your system, the longer the test will take.

6 When prompted, power cycle all Pro Tools peripherals in your system. Click Continue.

7 To test the interfaces connected to your system, check “Test I/O Box.”



LEDs on your digital interfaces may light up during this test. This is normal.

8 When the test is finished, you can view the test results by doing one of the following:

- Click the Get Results button next to a card name.
- Click the Results tab and choose a card slot from the pop-up menu.

9 In the Results page of the DigiTest window, click Show Failures Only to display failed tests for the selected card, or click Show All Results to display all test results for the selected card.

For descriptions of error codes, refer to Appendix B, “DigiTest Error Codes.”

10 Click Quit to close DigiTest.

11 Restart your computer.

Errors and Undetected Cards

Complete the steps below if any of the following occur:

- DigiTest fails to launch.
- An error message has been displayed for a card in DigiTest.
- A supported card is installed but not automatically detected during DigiTest.

If a supported card is installed and is not automatically detected:

- 1** Quit DigiTest.
- 2** Turn off the entire Pro Tools system.
- 3** Reinstall the cards (see “Installing the Pro Tools|HD Cards” on page 43).
- 4** Check the card seating.
- 5** Check the TDM FlexCable connections. Check the orientation of the cable from card to card (ports B to A), and check the integrity of the FlexCable connections to the cards.
- 6** Turn on the system.
- 7** Run DigiTest again.

Identifying Digidesign Cards with DigiTest

You can use DigiTest to identify which cards are in which slots in your system. This is especially useful if you have multiple Digidesign cards of the same type installed in your system.

To identify Digidesign cards with DigiTest

- 1** Quit Pro Tools if it is running.
- 2** Locate and double-click the DigiTest application on your hard drive.

DigiTest opens and lists the supported cards it finds in your system.

3 Open your computer case or expansion chassis so you can see the top edge of the cards installed in your system.

4 In the DigiTest window, select the ID check box next to a card name. The green LED near the top edge of the corresponding card flashes.

Viewing Card Information with DigiTest

DigiTest can display identifying information such as serial number, date of manufacture, and firmware ROM version, for each card in your system. This information is useful if you need to contact Digidesign Technical Support about your Pro Tools hardware.

To display information for a card in your system:

- 1** Quit Pro Tools if it is running.
- 2** Locate and double-click the DigiTest application on your hard drive.
- 3** Click the Slot Info tab.
- 4** Choose a card slot from the pop-up menu.

Updating Audio Peripheral Firmware with DigiTest

If firmware updates are available for any of your HD-series audio interfaces (192 I/O, the 192 Digital I/O, 96 I/O, or 96i I/O), you can use DigiTest to perform the update. Within DigiTest, the Firmware Update page tells you the firmware version for the selected peripheral and lets you update to a newer version, if necessary.

To update the firmware in an HD-series audio interface:

- 1** Quit Pro Tools if it is running.
- 2** Locate and double-click the DigiTest application on your hard drive.
- 3** Click the Firmware tab.

4 Choose a card slot from the pop-up menu. If any HD audio interfaces are connected to the card, the Primary or Secondary options will become available in the HD Peripheral section of the Firmware page.

If any connected interfaces are not recognized, check the connections and power to each interface and click Re-Scan.

5 Under HD Peripheral, select Primary or Secondary to view the firmware version for the corresponding interface. The firmware version is displayed just below the HD Peripheral section of the Firmware page.

6 If the firmware version is not current, click Begin Update to update the firmware in the selected audio interface.

The status of the firmware update process is displayed in the status area at the bottom of the Firmware page.

7 After the update process is complete, click Quit to close DigiTest.

Launching Pro Tools

When launching Pro Tools the first time, you are prompted to enter an authorization code to validate your software.

To validate Pro Tools software:

- 1** Double-click the Pro Tools application, located in the Pro Tools folder, inside the Digidesign folder.
- 2** Enter the authorization code in the dialog when prompted, making sure to observe any spaces, then click Validate.



The authorization code is located on the inside cover of this guide.

Configuring Pro Tools

Pro Tools System Settings

Pro Tools lets you adjust the performance of your system by changing *system settings* that affect its capacity for processing, playback, and recording.

In most cases, the default settings for your system provide optimum performance, but you may want to adjust them to accommodate large or processing-intensive Pro Tools sessions.

Voice Count

The Number of Voices setting lets you control the number of voices available on your system. For example, the default number of voices on an HD 1 system is 48 voices, using one DSP (at sample rates of 44.1 kHz or 48 kHz).

⚠ *Changing the number of voices affects DSP usage, the total number of voiceable tracks, and overall system performance.*

Depending on the current sample rate and the number of HD Core and HD Process cards in your system, you will have different choices for voice count.

 *For additional information on voice count, refer to the Pro Tools Reference Guide.*

To change the Voice Count:

- 1 Choose **Setup > Playback Engine**.
- 2 Select the number of voices and DSPs to allocate for voicing by choosing a value from the **Number of Voices** pop-up menu.

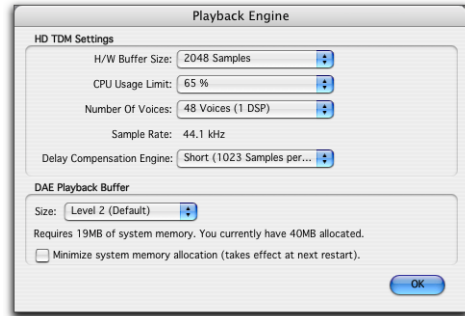

Playback Engine dialog for HD Accel system

- Select higher voice numbers when your Digidesign cards are the only PCI cards in your computer, or when you are using an expansion chassis to run higher track counts (such as 64 tracks at 96 kHz) and you want more voices per DSP (such as 16 voices per DSP at 96 kHz). These settings use fewer DSP chips for mixing (leaving more available for plug-ins) but place the highest processing load on each allocated chip.
- Select medium voice numbers when your Digidesign cards are in an expansion chassis, or when you are using other PCI cards along with Digidesign cards. These settings generally provide an optimum balance between number of chips needed for voicing, and the processing load placed on each.

- Select minimum voice numbers if you are using high-bandwidth PCI cards (such as video capture cards) along with your Digidesign cards. These settings place the lightest processing load on each allocated DSP chip, but generally require that more DSP chips be dedicated to voicing and mixing (leaving fewer available for plug-ins).

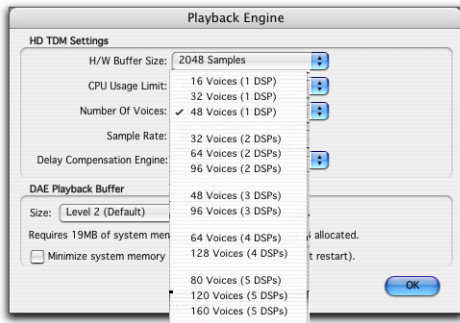

Number of Voices menu (HD Accel-equipped system)

- 3 Click OK.

Hardware Buffer Size

The Hardware Buffer Size (H/W Buffer Size) controls the size of the hardware cache used to handle host processing tasks such as Real-Time AudioSuite (RTAS) plug-ins.

- Lower Hardware Buffer Size settings reduce monitoring latency, and are useful when you are recording live input.
- Higher Hardware Buffer Size settings allow for more audio processing and effects, and are useful when you are mixing and using more RTAS plug-ins.

⚠ *In addition to causing slower screen response and monitoring latency, higher Hardware Buffer Size settings can affect the accuracy of plug-in automation, mute data, and timing for MIDI tracks.*

To change the Hardware Buffer Size:

- 1 Choose Setups > Playback Engine.
- 2 From the H/W Buffer Size pop-up menu, select the audio buffer size, in samples.
- 3 Click OK.

CPU Usage Limit

The CPU Usage Limit controls the percentage of CPU resources allocated to Pro Tools host processing tasks. The maximum CPU Usage Limit is 85 percent for single-processor computers, and 99 percent for multi-processor computers. (The 99 percent setting dedicates one entire processor to Pro Tools.)

- Lower CPU Usage Limit settings limit the effect of Pro Tools processing on other CPU-intensive tasks, such as screen redraws, and are useful when you are experiencing slow system response, or when running other applications at the same time as Pro Tools.
- Higher CPU Usage Limit settings allocate more processing power to Pro Tools, and are useful for playing back large sessions or using more real-time plug-ins.

⚠ *Increasing the CPU Usage Limit may slow down screen responses on slower computers.*

To change the CPU Usage Limit:

- 1 Choose Setups > Playback Engine.
- 2 From the CPU Usage Limit pop-up menu, select the percentage of CPU processing you want to allocate to Pro Tools.
- 3 Click OK.

Delay Engine

(Pro Tools 6.4 for Pro Tools|HD Systems Only)

The Delay Engine lets you enable Delay Compensation for managing DSP delays that occur on audio tracks, Auxiliary inputs, or Master Faders because of plug-in use and mixer routing. Pro Tools maintains time-alignment between tracks that have plug-ins with differing DSP delays, tracks with different mixing paths, tracks that are split off and recombined within the mixer, and tracks with hardware inserts.

To maintain time alignment, Pro Tools adds the exact amount of delay to each track necessary to make that particular track's delay equal to the delay of the track that has the *longest* delay.

Delay Compensation should be enabled during mixing and playback for optimal delay compensated sound. In some cases when recording, Delay Compensation should be turned off.

To enable Delay Compensation:

- Choose Operations > Use Delay Compensation.

Delay Compensation Settings

There are three settings in the Playback Engine dialog for dedicating DSP resources for Delay Compensation:

None Allocates no DSP resources for automatic delay compensation.

Short Allocates minimal DSP resources of delay compensation for each channel. This is the most efficient setting for Pro Tools|HD Accel systems.

Long Allocates maximum DSP resources of delay compensation for each mixer channel. Long delay compensation uses the same DSP resources used by high DSP overhead plug-ins.

To configure the Delay Compensation Engine:

- 1 Choose Setups > Playback Engine.
- 2 From the Delay Compensation Engine pop-up menu, select a Delay compensation setting.
- 3 Click OK.

The delay compensation option will be saved as a session and system preference.

DAE Playback Buffer Size

The DAE Playback Buffer Size determines the amount of memory DAE uses to manage disk buffers, which affects system performance.

- Lower DAE Playback Buffer Size settings can improve playback and recording initiation speed. However, a lower setting can make it difficult for slower hard drives to play or record tracks reliably.
- Higher DAE Playback Buffer Size settings can allow for a higher density of edits in a session. However, a higher setting can cause a time lag to occur before playback or recording begins. It can also cause a time lag to occur when you are editing during playback.

To change the DAE Playback Buffer Size:

- 1 Choose Setups > Playback Engine.
- 2 From the DAE Playback Buffer pop-up menu, select a buffer size. Memory requirements for each setting are shown at the bottom of the Playback Engine dialog.
- 3 Click OK.

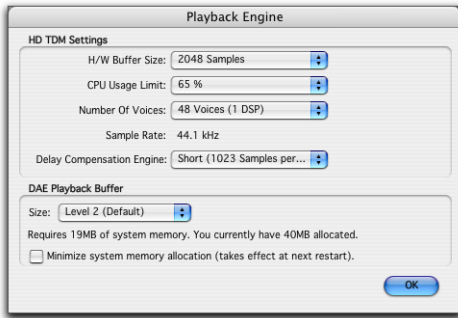

Playback Engine dialog for Pro Tools | HD system

If Pro Tools needs more system memory for the DAE Playback Buffer, it will prompt you to restart your computer.

System Memory Allocation

When you start your computer, Pro Tools automatically reserves a portion of system memory for the DAE Playback Buffer. This reserved memory is unavailable to other applications, even if Pro Tools is not running.

You can set Pro Tools to reserve only the minimum amount of required memory, so that more system memory is available to other applications.

To minimize system memory allocation:

- 1 Choose **Setup** > **Playback Engine**.
- 2 Select the “Minimize System Memory Allocation” option.
- 3 Click **OK**.
- 4 Restart your computer.

Pro Tools Hardware Settings

Pro Tools lets you set the default sample rate and clock source for your system, as well as a range of controls specific to each type of audio interface.

Default Sample Rate

The Sample Rate setting appears as the default sample rate when you create a new session. (This setting is available in the Hardware Setup dialog only when no session is open.)

 You can change the sample rate when creating a new Pro Tools session by selecting a different sample rate in the New Session dialog. (See “Starting a Session” on page 75.)

To change the default Sample Rate:

- 1 Make sure that no Pro Tools session is open.
- 2 Choose **Setup** > **Hardware Setup**.

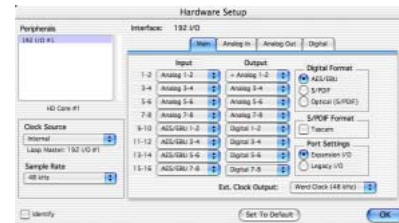

Hardware Setup dialog for 192 I/O, Main page

- 3 Choose the sample rate from the Sample Rate pop-up menu.
- 4 Click **OK**.

Sample Rates and Expanded Systems

With 176.4 kHz and 192 kHz sample rates, as many as four HD-series cards can be used. Any additional cards (up the total system maximum of seven cards) will switch to Inactive mode. The cards and any attached peripherals will become active when the system (or a session) sample rate is set to 96 kHz or lower. See also “Offline Peripherals” on page 66

Clock Source

The Pro Tools Hardware Setup dialog allows you to select the clock source for the system.

Internal If you are recording an analog signal directly into Pro Tools, you will usually use the Pro Tools Internal clock source.

External If you are transferring material into Pro Tools from an external digital device, or if you utilize a common house clock signal, you will synchronize Pro Tools to that digital device or common signal. Depending on your audio interface, external options can include AES/EBU [Encl], S/PDIF, Optical [Encl], AES/EBU 1–8, TDIF, ADAT, and Word Clock. For details, refer to the *Pro Tools Reference Guide* or the guide for your audio interface.

To select the Clock Source:

- 1 Choose Setups > Hardware Setup.
- 2 Select a clock source.
- 3 Click OK.

⚠ *Your digital input device must be connected and turned on for Pro Tools to synchronize to it. If your input device is not turned on, leave the Clock Source set to Internal.*

Configuring Audio Interfaces

Pro Tools|HD audio interfaces support 16 channels of simultaneous I/O and multiple I/O formats (including analog, AES/EBU, ADAT Optical, S/PDIF, and TDIF).

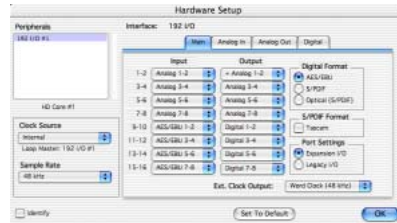

Hardware Setup dialog for 192 I/O, Main page

The Main page of the Hardware Setup dialog is where you define which physical inputs and outputs on your audio interface are routed to available inputs and outputs in Pro Tools. You can think of this window as a patchbay that allows you to route any of the inputs or outputs on your HD-series audio interfaces to channel assignments in the Pro Tools mixer.

The Main page also provides controls for defining whether Expansion Port or Legacy Port peripherals are active.

To configure the interfaces in your system, you select each interface in the Peripherals list and set the parameters for that interface.

Identifying Audio Interfaces

If you have multiple audio interfaces of the same type connected to your system, before you make audio connections to them, you should confirm the identity of each interface. This ensures that you choose the appropriate interface in the Peripherals list when you define its inputs and outputs in the Hardware Setup dialog.

To identify audio interfaces in your system:

- 1 Choose Setups > Hardware Setup.
- 2 From the Peripherals list, select an audio interface connected to your system.

 Use the Up and Down Arrow keys to scroll through the Peripherals list in the Hardware Setup dialog.

- 3 Make sure the Main page tab is chosen.
- 4 Select the Identify option, located in the lower left corner of the Hardware Setup dialog. This illuminates all the LEDs on the front panel of the selected audio interface.
- 5 Make a note of which interface in your studio setup corresponds to the identified interface.
- 6 Repeat the above steps for each additional audio interface in your setup.

 Legacy audio interfaces must be initialized in the Peripherals list before they can be identified. See “Configuring Legacy Audio Interfaces” on page 65.

To configure HD audio interfaces:

- 1 Choose Setups > Hardware Setup.
- 2 From the Peripherals list, select an audio interface connected to your system.
- 3 Make sure Main page tab is chosen.
- 4 From the Clock Source pop-up menu, select the appropriate clock source for the interface.
- 5 If you want to send clock output to other devices attached to the audio interface, select the appropriate output from the Ext. Clock Output pop-up menu.

If the Legacy I/O Port is enabled (and not the Expansion I/O Port) then the Ext. Clock Output automatically switches to Slave Clock (256x sample rate). To reset the Ext. Clock Output to

Word Clock, change the Port Settings back to Expansion I/O, then select the Legacy audio interface in the Peripherals list, and set it to No Interface in the Interface pop-up menu. (The 96i I/O does not support Legacy I/O.)

- 6 Select which digital I/O port on your audio interface enclosure is active by selecting an option under Digital Format. Depending on the type of interfaces in your system, choices include AES/EBU, S/PDIF, and Optical (S/PDIF). Selecting Optical (S/PDIF) resets the Optical I/O port (which is, by default, eight channels of ADAT Optical I/O) to two channels of S/PDIF Optical I/O. (The 96i I/O supports stereo S/PDIF RCA digital input and output only.) For more information about HD enclosure and card ports, refer to the guide for your audio interface.
- 7 For S/PDIF compatibility with Tascam DA-30 DAT recorders, select the Tascam option under S/PDIF Format.

- 8 From the Input and Output channel pop-up menus, select the physical ports (such as Analog 1–2 or Optical 1–2), that will be routed to the corresponding Pro Tools input and output channels (such as Ch 1–2, Ch 3–4), listed on the left side of the Main page. (This feature is not available with the 96i I/O.)

Inputs and outputs of similar format are differentiated in the input and output channel pop-up menus. For example, the AES/EBU inputs and outputs in the 192 I/O enclosure are listed as AES/EBU [Enc], while the AES/EBU inputs and outputs on the factory-installed Digital I/O card are listed (in pairs) as AES/EBU 1–2, AES/EBU 3–4, AES/EBU 5–6, and AES/EBU 7–8. For 192 I/Os equipped with the optional

Digital I/O Card, the additional AES/EBU I/O ports on the optional card are listed as AES/EBU 9–10, AES/EBU 11–12, AES/EBU 13–14, and AES/EBU 15–16.

 Refer to your peripheral's guide for configuration details and restrictions. For example, the Optical 1–8 channels (on the 192 I/O enclosure) will not be available at session sample rates of 88.2 kHz or higher, while the ports on the 192 I/O Digital I/O card will still be available.

9 Configure controls for your HD audio interface. See “Configuring 192 I/O and 192 Digital I/O Controls” on page 63, “Configuring 96 I/O Controls” on page 64, and “Configuring 96i I/O Controls” on page 65.

10 For additional HD-series audio interfaces, choose the interface in the Peripherals list, and repeat the above steps.

Configuring 192 I/O and 192 Digital I/O Controls

To configure controls for a 192 I/O:

1 With the 192 I/O selected in the Peripherals list, click the Analog In tab for the following options:

- You can set your operating level on a channel-by-channel basis by selecting Reference Level +4 dBu or –10 dBV. These settings correspond to two different input connectors on the rear of the 192 I/O. Refer to the *192 I/O Guide* for more information on setting operating levels.
- Each of the analog channels in the 192 I/O has two Input Trims, labeled A and B, for precisely calibrating and switching levels. You can select Input Trim A or B on a channel-by-channel basis. Refer to the *192 I/O Guide* for information on setting the rear panel trims.

- You can select Soft Clip on a channel-by-channel basis. The Soft Clip limiter attenuates the incoming analog signal, providing extra protection from temporary clipping transients that can cause digital distortion when they exceed the maximum input of the unit. With Soft Clip enabled, 192 I/O supports an additional 4 dB of headroom by rounding off the top 4 dB to the clip point. This is useful for eliminating stray transients or for emulating analog tape saturation.

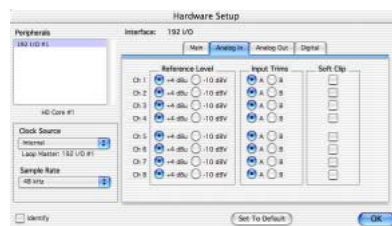

Hardware Setup dialog for 192 I/O, Analog In page

2 Click the Analog Out tab for the following option:

- Each of the analog channels in the 192 I/O has two Output Trims, labeled A and B, respectively. You can select Output Trim A or B on a channel-by-channel basis.

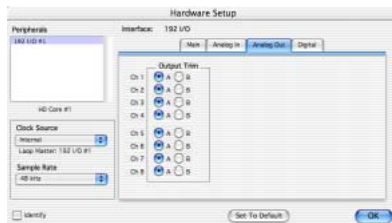

Hardware Setup dialog for 192 I/O, Analog Out page

To configure controls for a 192 Digital I/O or 192 I/O with an optional Digital I/O card:

■ On the 192 Digital I/O or a 192 I/O with an optional Digital I/O card, click the Digital tab to set the Input Format (AES/EBU, TDIF, or ADAT Optical) and enable real-time sample rate conversion (in channel pairs, with the SR Conversion option).

 At session sample rates above 48 kHz, sample rate conversion for the TDIF and Optical (ADAT) inputs on the Digital I/O card is automatically enabled on all eight inputs of the selected format.

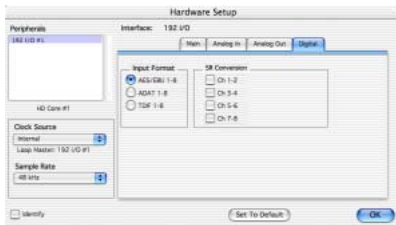

Hardware Setup dialog for 192 I/O, Digital page

Configuring 96 I/O Controls

To configure controls for a 96 I/O:

1 With the 96 I/O selected in the Peripherals list, configure your I/O front panel meters for input or output metering from the Meters pop-up.

2 Click the Analog In tab for the following option:

- You can set your operating level on a channel-by-channel basis by selecting Reference Level +4 dBu or -10 dBV. Refer to the *96 I/O Guide* for more information on setting operating levels.

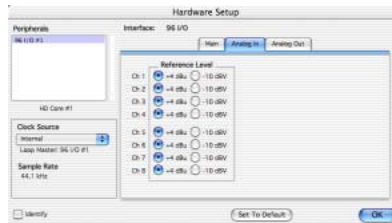

Hardware Setup dialog for 96 I/O, Analog In page

3 Click the Analog Out tab for the following option:

- You can set your output level on a channel-by-channel basis by selecting Reference Level +4 dBu or -10 dBV. Refer to the *96 I/O Guide* for more information on setting operating levels.

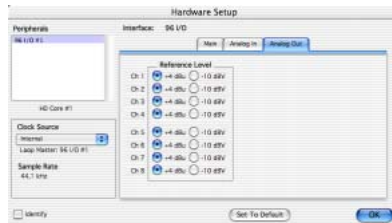

Hardware Setup dialog for 96 I/O, Analog Out page

Configuring 96i I/O Controls

To configure controls for a 96i I/O:

- 1 With the 96i I/O selected in the Peripherals list, configure your I/O front panel meters for input or output metering from the Meters pop-up.
- 2 Set input sensitivity.
 - For Inputs 1–4, set the input trim slider to match the output level of the connected instrument. Choices range from –12 dBV to +4 dBu. If you do not know the output level of the device, use the default input trim level, then fine tune the input level sensitivity.
 - For each input 5–16 being used, select –8 dBV or +4 dBu as appropriate to best match the output level of the connected instrument.
- 3 Set Output levels (select –10 dBV or +4 dBu).

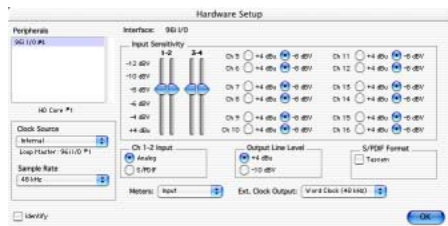

Hardware Setup dialog for 96i I/O

- 4 Click Done.

You can select either the analog or digital inputs as sources for 96i I/O channels 1–2. Only channels 1–2 can access the S/PDIF inputs.

To select analog or digital input for channels 1-2:

- 1 Choose Hardware > Setup, and select 96i I/O in the Peripherals list to display the 96i I/O window.
- 2 Click to set Ch 1–2 Input to Analog or S/PDIF, as appropriate.

 *The 96i I/O only supports analog and digital switching for channels 1–2, and only from within the Hardware Setup and I/O Setup dialogs. The 96i I/O does not support path remapping within I/O Setup.*

Configuring Legacy Audio Interfaces

Before you can configure a Legacy audio interface, it must first be initialized in Hardware Setup.

To initialize a Legacy audio interface:

- 1 Make sure to lower the volume of your output devices. Very loud digital noise may be emitted before the Legacy audio interface is initialized.
- 2 Turn on your Legacy audio interface.
- 3 From the Peripherals list, choose the primary audio interface (the interface to which your Legacy audio interface is connected).
- 4 In the Main page of the Hardware Setup dialog, select the Legacy I/O option under Port Settings.
- 5 In the Peripherals list, “No Interface” is listed twice, directly below the primary audio interface. Click the first “No Interface.” An Interface pop-menu appears in the Hardware Setup dialog, listing supported I/O choices.
- 6 From the Interface pop-up menu, select the type of Legacy audio interface you connected. (If your Legacy interface does not appear, check connections and repeat from step 1, above. See also “Offline Peripherals” on page 66.)

After you select the type of Legacy audio interface, the Main page updates with controls that can be configured.

7 Repeat the above steps for each additional Legacy audio interface.

 For more information on Hardware Setup controls for each I/O, refer to its guide.

Offline Peripherals

When a Legacy audio interface and HD peripheral are connected to your primary HD peripheral, only one can be online at a time. An offline peripheral is indicated by brackets in the Peripherals List of the Hardware Setup dialog. For example, if you have a 96 I/O and an 882|20 connected to a 192 I/O, and the 96 I/O is offline, it will appear in the Peripherals List as “[96 I/O].”

Pro Tools|HD peripherals (and any attached Legacy I/Os) will also go offline if the primary audio interface to which they are attached is offline, or if the HD card to which they are attached is made inactive. See “Sample Rates and Expanded Systems” on page 60 for more information.

Configuring I/O Setup

The I/O Setup dialog provides a graphical representation of the signal routing for each connected audio interface, with controls to route physical ports to Pro Tools inputs and outputs. These controls mirror the routing controls found in the Hardware Setup dialog—changes made to physical routing in one dialog are always reflected in the other. The I/O Setup dialog also lets you label and map Pro Tools input, output, insert, and bus *signal paths*.

Pro Tools comes with default I/O Setup settings that will get you started. You only need to go to I/O Setup if you want to remap or rename the default I/O paths or if you change your system hardware (for example, adding an expansion card to a 192 I/O).

 Refer to the Pro Tools Reference Guide for more information on setting up I/O paths.

To configure I/O routing in I/O Setup:

- 1 Choose Setups > I/O Setup.
- 2 Click the Input or Output tab to display the corresponding connections.
- 3 To change the name of a path or subpath, double-click directly on the Path Name, type a new name for the path, and press Return.
- 4 To change the destination of an Input or Output path or subpath, click directly on an Input or Output Selector for an interface channel pair, just below an audio interface icon. (This feature is not available with the 96i I/O.)
- 5 From the pop-up menu, select a physical port pair (such as Analog 1–2), to route to the corresponding Pro Tools channel pair (such as A 1–2) in the Path Name column on the left.
- 6 Repeat the above steps for additional channel pairs.
- 7 Click OK.

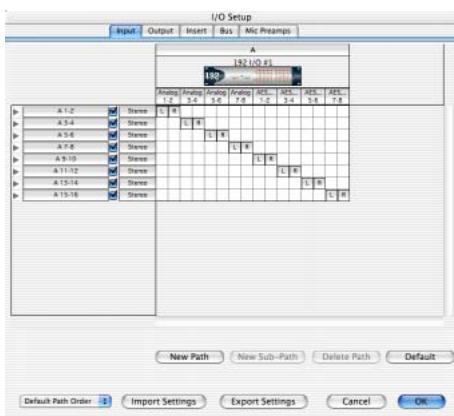

I/O Setup dialog for a Pro Tools HD system

Routing a Pro Tools Output Pair to Multiple Destinations

Pro Tools channel pairs can be routed to multiple outputs on your Digidesign audio interface through the Hardware Setup dialog.

For example, if Pro Tools Outputs 1–2 are assigned to both Analog 1–2 and Digital 1–2, that signal will be routed simultaneously to both pairs of output ports on your audio interface.

This lets you send the same signal (such as a stereo pair, a stem mix, or a multichannel mix) to multiple destinations (such as multiple master devices).

To route a Pro Tools output channel pair to multiple audio interface output ports:

- 1 Choose Setups > Hardware Setup.
- 2 From the Peripherals list, select an interface.
- 3 Click the Main tab.
- 4 Select an output pair from an Output pop-up menu.
- 5 Control-click the same pop-up menu to choose an additional output pair.

The output name updates with a plus sign (“+”) before it to indicate that multiple output ports are selected. In the pop-up menu, each physical port pair assigned to that Pro Tools output pair is indicated by a check mark.

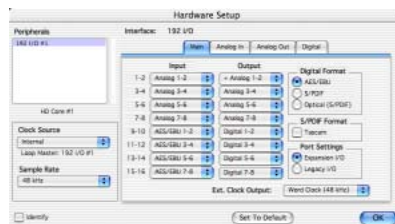

Hardware Setup dialog for 192 I/O, Main page

- 6 Repeat the above steps to select additional output destinations. The only limit to output choices is the number of outputs available in your system.

chapter 4

Connecting Your Studio

This chapter provides general information on connecting Pro Tools to your system, including digital equipment, effects units, MIDI gear, and SMPTE synchronization devices.

Refer to the *192 I/O Guide*, *192 Digital I/O Guide*, *96 I/O Guide*, or *96i I/O Guide* for specific details regarding:

- Front and back panel connectors and indicators
- Installation of optional expansion I/O cards (192 I/O only)

⚠ *HD audio interfaces need room at their sides to maintain proper air flow for cooling. Do not block the sides of the unit or disconnect the internal fan. If the units are rack-mounted in a case, remove the case lids or doors before operating the system. Failure to do so can result in the units overheating very quickly, which can permanently damage sensitive components.*

Setting Up Your Studio

Figure 6 illustrates a typical studio setup, with a 192 I/O connected to a mixing console, effects and other equipment.

Figure 7 illustrates a setup without a mixer, where effects and monitoring gear are connected directly to a 96 I/O.

Example Studio Setup with a Mixing Console

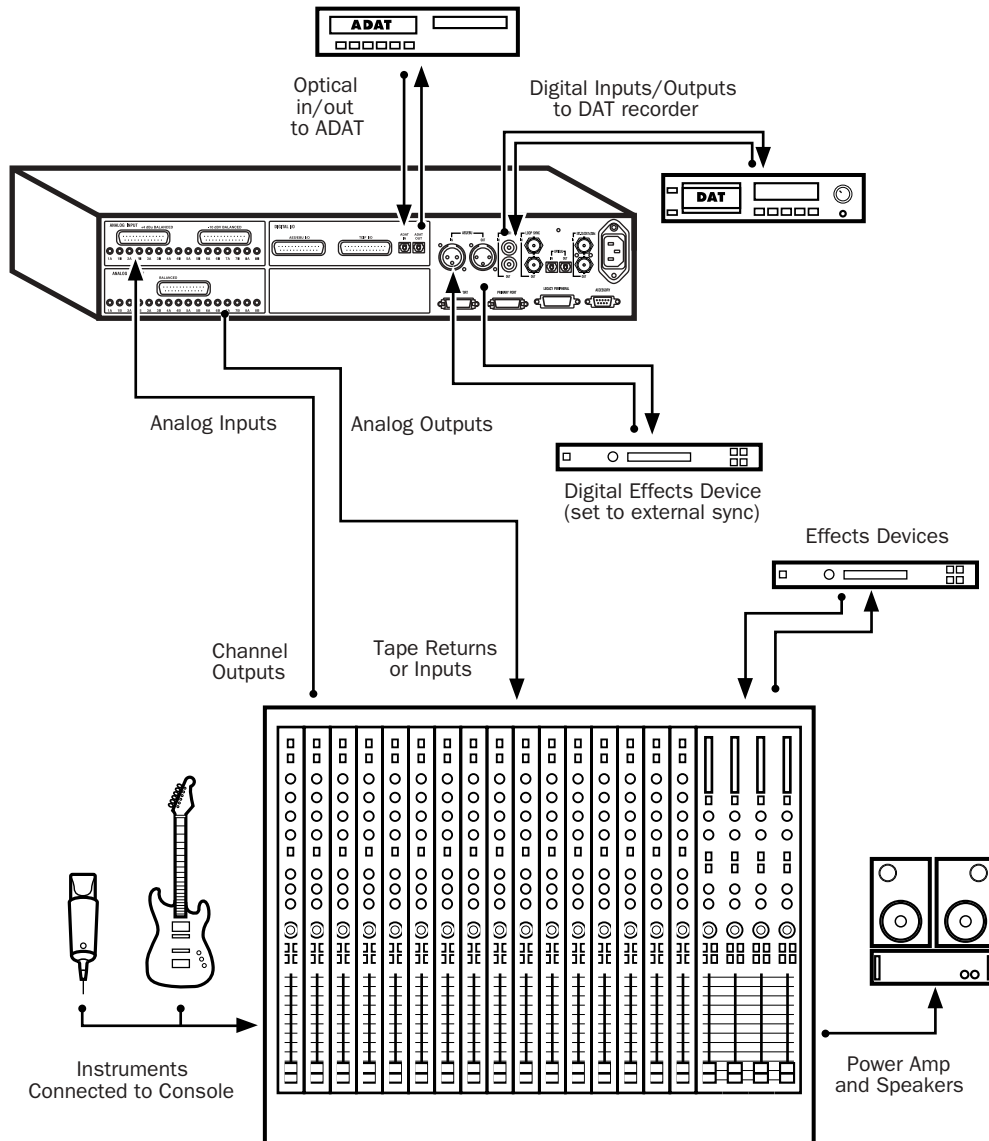

Figure 6. Typical studio configuration using a 192 I/O with mixer connections

Example Studio Setup without a Mixing Console

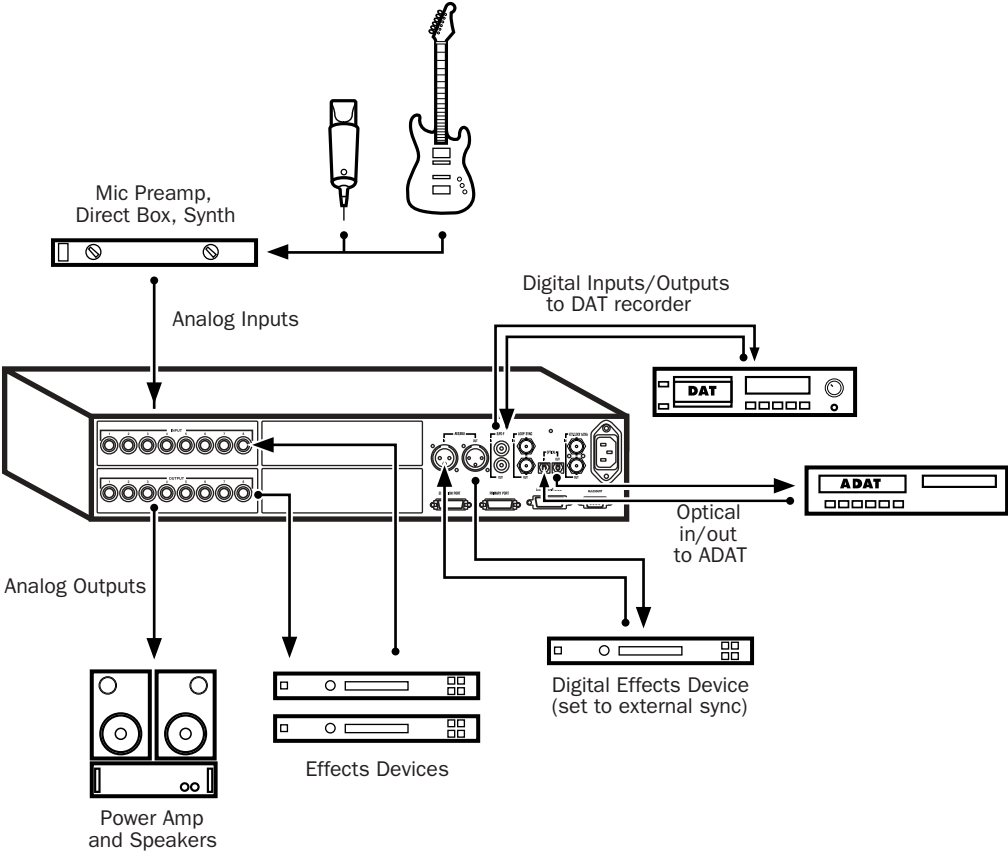

Figure 7. Typical studio configuration using a 96 I/O without a mixer

192 I/O

The 192 I/O features two DB-25 breakout connectors for two sets of eight inputs each, at +4 dBu and -10 dBV respectively.

There are no -10 dBV outputs, however; analog outputs break out from a single DB-25 output at +4 dBu operating levels.

⚠ *When driving unbalanced lines on the 192 I/O output card, leave the negative “-” terminals disconnected. Failure to do so will result in noisy outputs.*

The 192 I/O requires a custom DB-25 snake. Digidesign sells several different DigiSnake (DB-25) cables for this purpose. Contact your dealer or Digidesign for more information.

192 Digital I/O

The 192 Digital I/O features two DB-25 breakout connectors for two sets of eight AES/EBU or TDIF inputs and outputs, along with a pair of ADAT Optical ports.

The 192 Digital I/O requires a custom DB-25 snake. Digidesign sells several different DigiSnake (DB-25) cables for this purpose. Contact your dealer or Digidesign for more information.

96 I/O

The 96 I/O analog connectors are TRS 1/4-inch with TIP wired hot (or “+”), RING cold (or “-”), and SLEEVE ground. If connecting to unbalanced loads, use unbalanced TS cables.

There is one bank of eight inputs (software-switchable between +4 dBu and -10 dBV line levels on a line-by-line basis).

There is one bank of eight outputs (that use +4 dBu line levels).

96i I/O

The 96i I/O analog connectors are balanced TRS 1/4-inch with TIP wired hot (or “+”), RING cold (or “-”), and SLEEVE ground. If connecting to unbalanced loads, use unbalanced TS cables.

The 96i I/O provides 16 inputs and two outputs. Inputs 1-4 feature variable, multi-level input sensitivity, controllable from within Pro Tools (from -12 dBV to +4 dBu). Inputs 5-16 provide a choice of two fixed operating levels (-8 dBV or +4 dBu).

Outputs 1-2 are selectable between -10 dBV and +4 dBu.

Connecting Equipment with Digital Audio Ins and Outs

Each Pro Tools HD audio interface includes at least one AES/EBU, S/PDIF, or ADAT digital option. For example, the 192 I/O includes additional AES/EBU and optical ports, as well as TDIF, dual-wire AES/EBU at 192 kHz, and sample rate converters. The 96i I/O provides two channels of S/PDIF only. (See the documentation for your audio interface for details.)

The following example provides basic setup guidelines for connecting Pro Tools to a DAT recorder. For detailed information for recording to and from an ADAT, see “Recording To and From Digital Devices” on page 90.

To connect your Pro Tools system to a DAT recorder:

1 Connect the AES/EBU or S/PDIF output on the enclosure of your HD audio interface to the AES/EBU or S/PDIF input of your DAT deck. By default, this port is assigned to Pro Tools Output 1-2.

2 Connect the AES/EBU or S/PDIF input on the enclosure to the AES/EBU or S/PDIF output of your DAT deck. Route the digital input to Pro Tools inputs in the Hardware Setup dialog.

 You can route any of the physical input or output pairs to any of the input and output channel assignments in the Pro Tools mixer. (The 96i I/O does not support input mapping, however.) For more information see the Pro Tools Reference Guide.

Connecting Effects Units

The 192 I/O, 192 Digital I/O and 96 I/O let you connect analog or digital effects units to your Pro Tools system, and use them as inserts or make them the destination for effects sends and returns. (The 96i I/O supports a single pair of hardware inserts using channels 1–2. See the 96i I/O Guide for more information.)

Five inserts are available on each audio channel. Each insert can be a hardware insert (or software plug-in), and can be mono or stereo.

When using a hardware insert, you can connect the device to matching inputs and outputs on your system. For example, a stereo insert could use outputs 7–8 and inputs 7–8 for the sends and returns, respectively. Routing the physical inputs and outputs of the interface to Pro Tools inputs and outputs can be done in either the Hardware Setup dialog or I/O Setup dialog. From I/O Setup, inserts can also be defined, and their channels mapped to audio interface channels. (For more information, see the *Pro Tools Reference Guide*).

You can also connect effects units to your system by using any analog or digital inputs and outputs as Auxiliary Inputs and Outputs for effects sends and returns. Once an effects unit is attached this way, you can send a variable amount of a track's output to the effects unit using a *send fader* in Pro Tools.

Five separate send controls on each Pro Tools track allow you to route audio to any of the available outputs connected to your system or through any of the 64 internal busses in the Pro Tools TDM Mixer. Outputs can be returned to mono or stereo Auxiliary Inputs for automated mixing or processing.

When you are using an effect in this send and return type of configuration, make sure the unit's internal mix or balance between direct (unprocessed) and wet (effected) signal is set so that only the processed signal is returned to Pro Tools. On most effect units, a balance setting of 100% (completely wet) is the appropriate setting.

If you've been using an effects unit in an instrument setup, such as a guitar effects rack, you'll probably find the balance to be below 50%. If the unit has separate dry and effect level knobs, turn dry level control off. If you don't do this, the dry, unprocessed signal will be present in an effect's output along with the desired processed sound, and you'll have trouble accurately controlling the effect balance in your final mix.

Connecting Effects Units Digitally

To use your audio interface's inputs and outputs as effects sends and returns to a digital effects device, set your interface's Clock Source to Internal in the Hardware Setup dialog (unless it is referenced to another clock source or peripheral). You should then set your digital effects devices to accept an external digital clock so that they will synchronize themselves to Pro Tools. Make sure you set the channel pair to the digital input in the Hardware Setup dialog (or I/O Setup dialog).

Connecting MIDI Devices

By adding a compatible MIDI interface to your system, you can take advantage of all the MIDI features of Pro Tools, including recording and editing MIDI tracks, and synchronizing to MIDI Time Code or MIDI beat clock.

USB MIDI interfaces work effectively with Pro Tools systems on Windows or Macintosh. Serial MIDI interfaces are supported on Windows systems only.

▲ *Only USB MIDI interfaces are compatible with Pro Tools systems for Mac OS X. Modem-to-serial port adapters and serial MIDI devices are not supported.*

See Appendix G, "Configuring AMS (Mac OS X Only)" for information on configuring Audio MIDI Setup and your MIDI devices.

To connect MIDI devices to your system:

1 Connect the MIDI interface to your computer according to the MIDI interface's documentation.

2 Install any MIDI driver software required by the MIDI interface. (Once you have installed your MIDI interface hardware and software, confirm that it is working properly using the procedure given in the interface's documentation.)

3 Connect the MIDI OUT of your MIDI device to the MIDI IN of your MIDI interface.

4 Connect the MIDI IN of your MIDI device to the MIDI OUT of your MIDI interface.

Connecting SMPTE Synchronization Devices

If you intend to synchronize Pro Tools to external devices with SMPTE, your system must be connected properly. For details on SMPTE and synchronization, see the *Pro Tools Reference Guide* or the *SYNC I/O Guide*.

Digidesign SYNC I/O

Digidesign's SYNC I/O is a multi-purpose synchronization peripheral that provides all the functions and connections needed to synchronize to a variety of devices with Pro Tools.

SYNC I/O lets you synchronize Pro Tools to LTC, VITC, and Bi-Phase/Tach, or internal for positional reference (time code), and supports all major clock references.

SYNC I/O integrates into the Loop Sync configuration of an HD-series system, offering extremely fast lockup, near-sample accurate synchronization, and an exceptionally low-jitter clock. These features provide professional performance and maximum audio fidelity under a wide range of synchronization conditions.

For more information, refer to the *SYNC I/O Guide*.

chapter 5

Working with Pro Tools

This tutorial of Pro Tools software introduces its main windows and features, and also includes a step-by-step overview of audio recording (see “Basic Recording” on page 88).

All features described in this chapter are explained fully in the *Pro Tools Reference Guide*.

You can view an electronic PDF version of the *Reference Guide* by choosing it from the Pro Tools menu.

Session Basics

Pro Tools projects are created and saved as *sessions*. Sessions store all tracks, audio, MIDI, and other session information. Audio and fade files are stored in folders within the session folder.

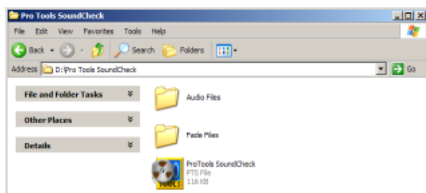

Session folder, containing the session file and its Audio Files and Fade Files folders

Starting a Session

To create a new session:

- 1 Launch Pro Tools.
- 2 Choose File > New Session.
- 3 In the New Session dialog, set the sample rate, bit depth, and other options for the new session.

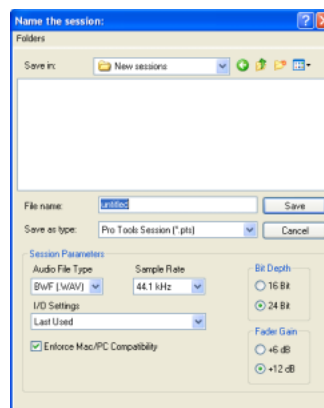

New Session dialog

- 4 Select where you want to save your session. If you are using external hard drives with your Pro Tools system, make sure you select the appropriate drive in the New Session dialog.
- 5 Type a name for your session.
- 6 Click Save. The new session opens its Mix, Edit, and Transport windows (see Figure 8 on page 76).

Main Windows

The Mix, Edit, and Transport windows are the main Pro Tools work areas. You can show any of these windows by choosing them from the Windows menu.

 Press **Command+Equals (=)** on Macintosh, or **Control+Equals (=)** in Windows to switch between the Edit and Mix windows.

Mix Window Displays the Pro Tools mixer, with its familiar fader strip controls for volume, pan, solo, mute, and signal routing.

Edit Window Displays tracks in the session along the Timeline, for editing of audio, MIDI, and automation data.

Transport Provides standard transport controls for Play, Stop, Rewind, Fast-Forward, Pause, and Record. The Transport window can also show Counter and MIDI Control displays.

Session Setup Provides status display for important Pro Tools session settings, including sample and frame rate, clock source, and file format. Also includes the Current Time Code counter, and controls for clock reference, positional reference, and other time code features for the Digidesign SYNC I/O.

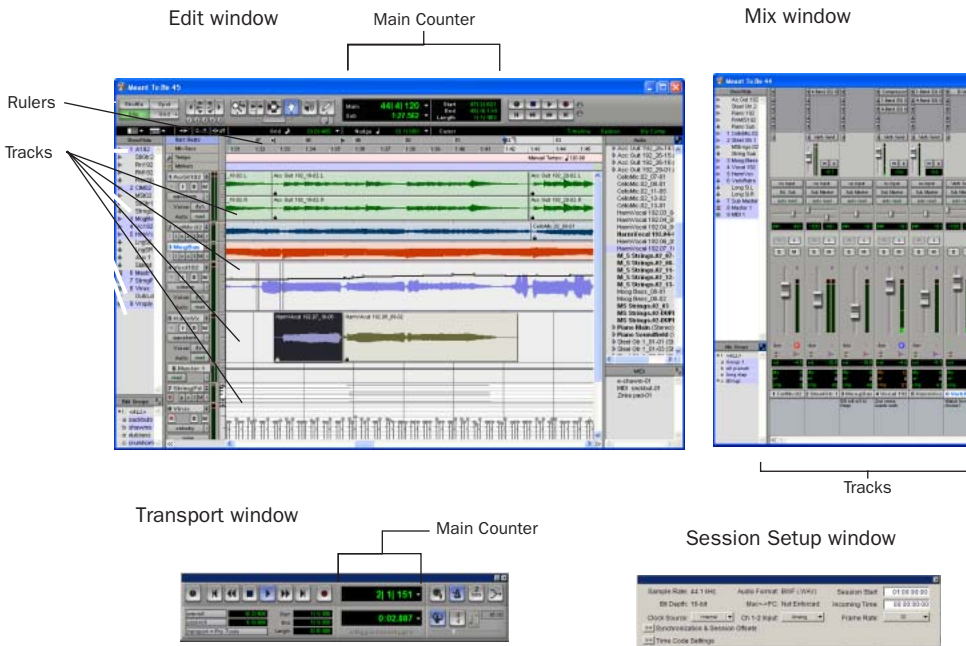

Figure 8. Main session windows

Rulers

Pro Tools provides several different rulers to select as the timebase for your session.

Timebase Rulers, displayed along the top of the Edit window, include *Bars:Beats*, *Minutes:Seconds*, *Samples*, *Time Code*, and *Feet:Frames*. The current timebase determines the format of the Main counter, and provides the basis for the Edit window Grid.

For post production, select either Time Code or Feet+Frames as your session Timebase in the Rulers view.

To select a Timebase Ruler:

- Click the name of the ruler at the top left side of the Edit window (*Bars:Beats*, *Minutes:Seconds*, *Samples*, *Time Code*, or *Feet:Frames*).

Setting a Tempo

You can set the tempo for your session using Tempo Events, or using the MIDI tempo controls in the expanded Transport window.

To insert a tempo event:

- 1 Choose Windows > Show Tempo/Meter.
- 2 At the top of the Tempo/Meter Change window, choose Tempo Change from the pop-up menu.

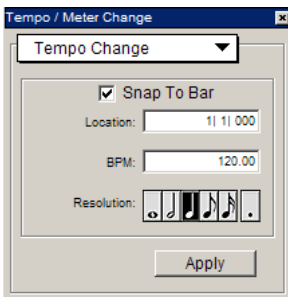

Tempo/Meter Change window

- 3 Enter the beats per minute (BPM) value you will use for the session and set the Location to 1|1|000 (so the inserted tempo event replaces the default tempo).
- 4 To base the BPM value on different note value (such as an eighth-note rather than the default quarter-note), select a note value.
- 5 Click Apply to insert the new tempo event.

Using the Click Plug-In

The Click plug-in creates an audio click during session playback. This works like a metronome that you can use as a tempo reference when performing and recording.

The Click plug-in is synchronized to the tempo and meter of the Pro Tools session, and follows any changes in tempo and meter.

 *The Click plug-in is one of many plug-ins that can be inserted on a Pro Tools track. See "Plug-Ins" on page 99.*

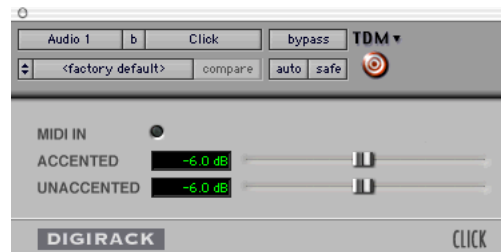

Click plug-in

Click Parameters

MIDI In LED Illuminates each time the Click plug-in receives a click message from the Pro Tools application, indicating the tempo.

Accented Controls the output level of the accented beat (beat 1 of each bar) of the audio click.

Unaccented Controls the output level of the unaccented beats of the audio click.

To use the Click plug-in:

1 Choose MIDI > Click to enable the Click option.

– or –

Enable the Click button in the Transport window.

2 Create a mono Auxiliary Input (Aux Input). This is the track.

3 Insert the Click plug-in.

4 From the Click plug-in window, select a Click sound preset.

- Click on the Factory Default pop-up menu, and select a Click sound.

5 Choose MIDI > Click Options and set the Click and Countoff options as desired. (Click OK to apply these options.)

▲ *The Note, Velocity, Duration, and Output options in this dialog are for use with MIDI instrument-based clicks and do not affect the Click plug-in.*

📖 *Refer to the Pro Tools Reference Guide for more information on configuring Click options.*

6 Begin playback. A click is generated according to the tempo and meter of the current session and the settings in the Click Options dialog.

Using an External MIDI Click

Pro Tools also provides a MIDI Click option that lets you use an external MIDI device to play a click. This feature can be turned on and off in the Transport window, and is configured from the MIDI Click Options dialog.

To configure and enable an external MIDI click:

1 Choose MIDI > Click Options.

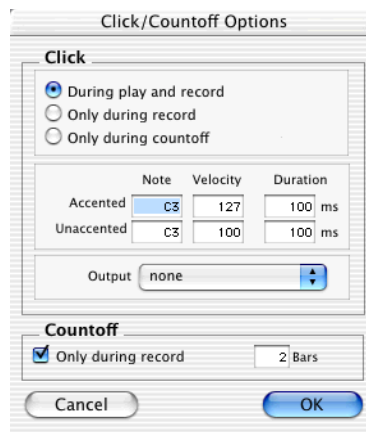

Click/Countoff Options dialog

2 Configure the click parameters as needed for your MIDI sound source.

▲ *If you are using a Macintosh, your MIDI studio must be configured with AMS. For more information, see Appendix G, “Configuring AMS (Mac OS X Only).”*

3 Select the desired MIDI sound source from the Output pop-up menu and click OK.

4 During recording or playback, you can turn the Click on or off with the Metronome button in the MIDI Controls display of the Transport window.

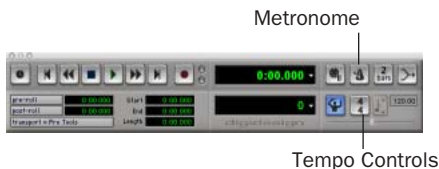

Click and Tempo Controls in the Transport window

Saving Sessions

As you build a session by adding tracks and changing session controls, you will want to save your work. Pro Tools provides three ways to save sessions.

To save a session:

- Choose File > Save Session, Save Session As, or Save a Session Copy In.

Save Session Saves the currently open session file, leaving it open for you to continue working.

Save Session As Creates a duplicate session file with the name you choose, and leaves the duplicate open for you to continue working. It does not create a new Audio Files or Fade Files folder. This can be useful if you want to experiment with different arrangements in the session without affecting the original session.

Save Session Copy In Saves copies of the session file and the files that you are using in the current session. This can be useful for creating a final copy of the session that does not include audio files or fades you are no longer using.

System Resources and Settings

You can change specific Pro Tools system settings in the Playback Engine dialog to optimize system performance.

Playback Engine Dialog

The Playback Engine dialog lets you adjust system buffer sizes and allocate CPU processing power to Pro Tools.

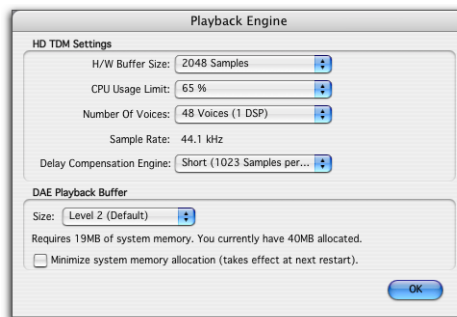

Playback Engine dialog for Pro Tools | HD series system

To configure system resources:

- Choose Setups > Playback Engine.

 For Windows systems, see Chapter 2, “Windows Configuration.” For Macintosh systems, see Chapter 3, “Macintosh Configuration.”

System Usage Window

The System Usage window displays approximate information on CPU load, DSP usage, and overall disk performance. Use this window to gauge your system's basic processing capacity. Monitor CPU usage if you are using RTAS plugins, and DSP usage if you are using TDM plugins.

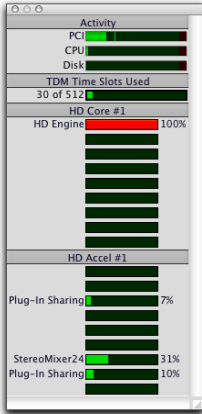

Meters in the System Usage window in a new session

To view system resources and usage:

- Choose Windows > Show System Usage.

Transport Controls

The Transport window provides access to all Pro Tools transport commands. Different transport controls can be displayed or hidden in this window.

To show the Transport window:

- Choose Window > Show Transport Window.



Transport window (Expanded view shown)

To configure the Transport window:

- Choose Display > Transport Window Shows and select from the view options.

In standard view, the Transport window provides Play, Stop, and other standard transport controls. The Expanded Transport window provides pre- and post-roll, start, end, and length indicators for Timeline selection, as well as the Transport Master selector.

The Transport window can also display the following MIDI controls: Wait for Note, Click, Countoff, MIDI Merge, Conductor, Meter, and Tempo.

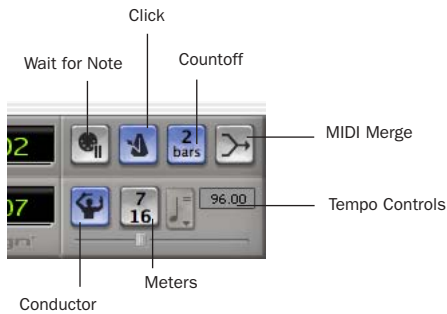

Transport window (MIDI Controls)

To start and stop playback:

- 1 Click Play in the Transport window to begin playback.
- 2 Click Stop in the Transport window to stop playback.

 Press the Spacebar on your computer keyboard to start and stop playback.

 Pro Tools starts playing from the location of the cursor, or from the beginning of the current selection. The current setting of the Link Edit/Timeline command in the Operations menu also affects playback. See the Pro Tools Reference Guide for more information.

Tracks

Pro Tools lets you create audio and MIDI tracks for audio and MIDI recording, submixing, routing, automating, and editing.

Pro Tools provides four types of tracks: audio tracks, Auxiliary Inputs, Master Faders, and MIDI Tracks. Audio tracks, Auxiliary Inputs, and Master Faders can be mono, stereo, or any of the supported multichannel formats for surround mixing.

Audio Tracks Record and play back audio to and from hard disk, monitor audio input when record-enabled, and edit audio regions

Auxiliary Inputs Audio mixer channels used for input, routing, and submixing

Master Faders Provide master channel controls and options for any Output or Bus path

MIDI Tracks Record, play back, and edit MIDI data

To create a new track:

- 1 Choose File > New Track.

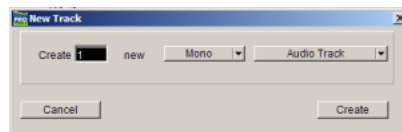

New Track dialog

- 2 Specify the number of tracks, track type, and mono or stereo (for all types except MIDI).

- 3 Click Create.

In the Mix window, audio tracks, Auxiliary Inputs, Master Faders, and MIDI tracks appear as vertical channel strips. Track type is indicated by the Track Type icons just below the faders, and by the color of the track names.



Tracks in the Mix window

In the Edit window, tracks are displayed horizontally along the Timeline. The area in which audio appears for each track is the Playlist.

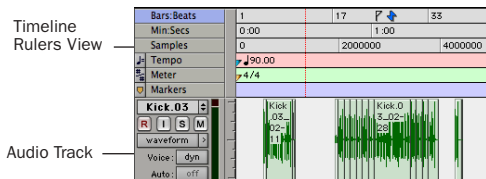

Timeline Rulers and a stereo audio track in the Edit window

Audio tracks, Auxiliary Inputs, Master Faders, and MIDI tracks can be automated. (See “Mix Automation” on page 100 for more information.)

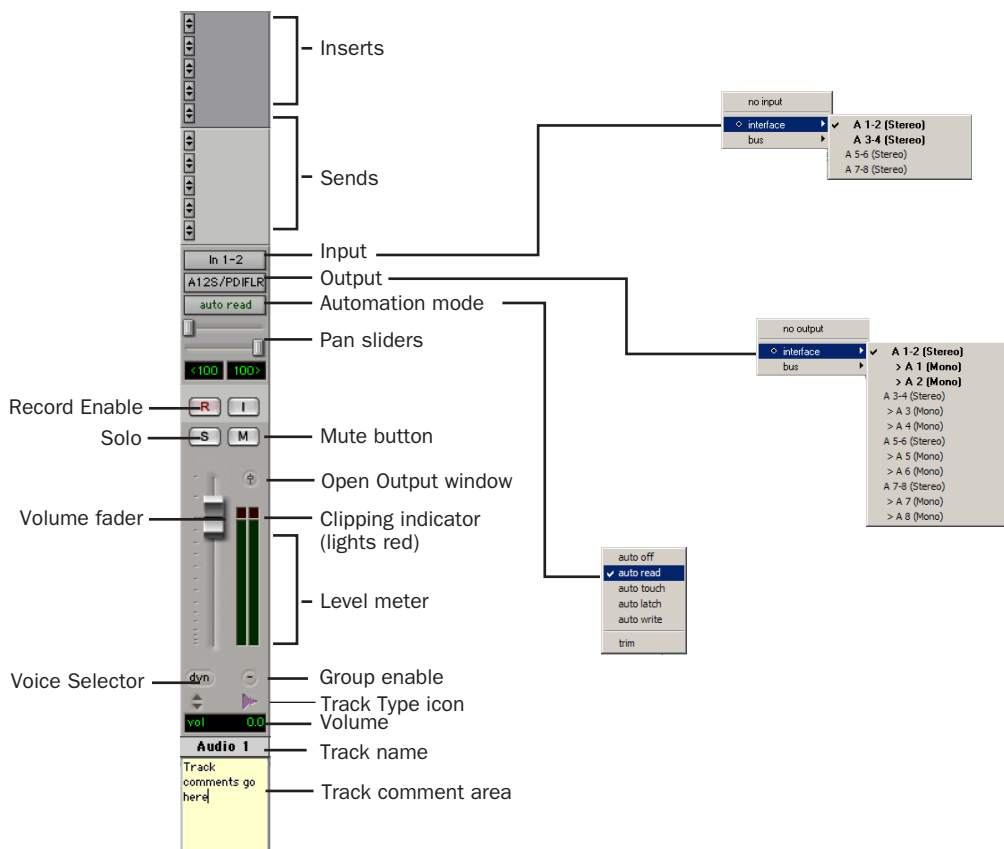

Figure 9. Stereo audio track in the Mix window

Audio Tracks

Audio tracks, Auxiliary Inputs, and Master Faders share many identical controls. Figure 9 shows the controls found in an audio or Auxiliary Input track. Master Faders provide all the same features as audio tracks and Auxiliary Inputs, with the following exceptions:

Input Selector A Master Fader's output assignment determines its input, or source.

Inserts Inserts on Master Faders are post-fader only. (Audio track and Aux input track inserts are all pre-fader.)

Sends Master Faders do not provide sends. To send an output to another destination, use an Auxiliary Input.

MIDI Tracks

MIDI tracks provide volume, solo, and mute, in addition to MIDI input, output, channel, and program (patch) controls. MIDI volume, mute, and pan can also be automated using Pro Tools automation features (see “Mix Automation” on page 100 for more information).

Regions Lists

A region is a piece of audio or MIDI data that can also have associated automation data. For example, a region could be a loop, a guitar riff, a verse of a song, a sound effect, a piece of dialog, or an entire sound file. In Pro Tools, regions are created from audio or MIDI files, and can be arranged in audio and MIDI track playlists.

All regions that are recorded, imported, or created by editing appear in the Audio and MIDI Regions Lists. Regions can be dragged from either list to tracks and arranged in any order. Audio regions can also be auditioned from the Regions Lists by Option-clicking (Macintosh) or Alt-clicking (Windows) the audio region name.

The Regions List pop-up menus provide many useful features for managing regions and files (such as sorting, selecting, importing, or exporting files).

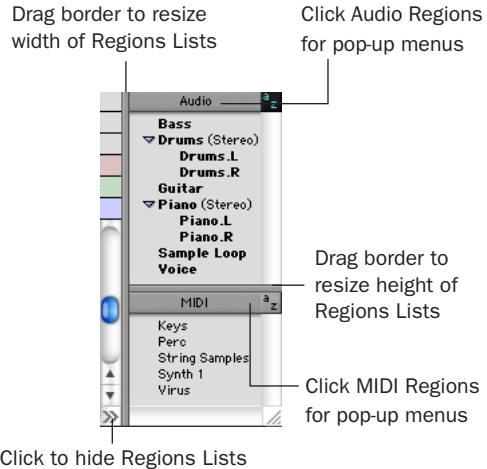

Audio and MIDI Regions Lists

 For more information on Regions Lists, refer to the Pro Tools Reference Guide or the *Di-giBase Guide*.

Navigating in a Session

Pro Tools provides many ways to navigate in a session, including using the mouse or entering a memory location into one of the counters.

To navigate to a location in the Edit window:

- 1 Select Operations > Link Edit and Timeline Selection.
- 2 Enable the Selector tool at the top of the Edit window by clicking it.



Edit tools in Edit window

- 3 Click in a track or Timebase Ruler. The cursor appears at the selected location and the counters display the current time location.

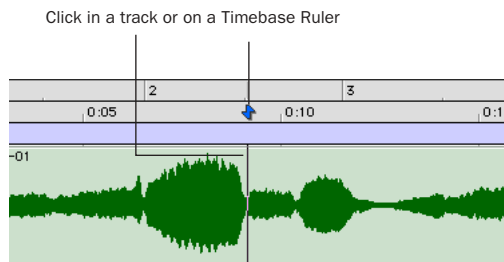

Clicking with the Selector in the Edit window

To navigate using the counters:

- 1 Click in the Main counter and enter a location using your computer keyboard.

- 2 Press Enter (Windows) or Return (Macintosh).



Navigating with the Counter

 Press the * (asterisk) key on the numeric keypad as an alternative to clicking in the counter. (The cursor will always appear in the Transport window's Main Counter if it is displayed.)

Memory Locations

Memory Locations provide another way to navigate within sessions. Memory Locations appear as markers under the Timebase Rulers.

To define a memory location:

- 1 Navigate to the location at which you want to store a marker or memory location.

– or –

Begin playback.

- 2 Press Enter on the numeric keypad while stopped or during playback (or click the Markers icon).

In the New Memory Location window, you can define a marker, store a selection, or store any combination of the other available settings. These settings include track height, group enables, pre- and post-roll values, and track Show/Hide status.

- 3 Choose settings for the memory location and click OK.

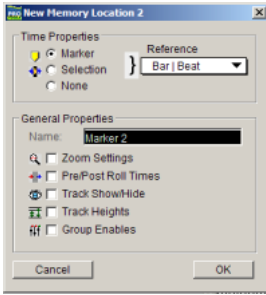

New Memory Location window

To go to a stored Memory Location:

- 1 Choose Windows > Show Memory Locations.
- 2 In the Memory Locations window, click the name of the memory location.

Viewing and Zooming

When viewing tracks in the Edit window, you can adjust the height of tracks as well as zoom in vertically and horizontally using the Track Height selector and Zoom tools.



Zoom and Track Height tools in the Edit window

To change track height:

- Click the Track Height Selector, and select a track height from the pop-up menu.

 You can apply many commands, including track height selection, to more than just a single track. Hold down the Option key (Macintosh) or Alt key (Windows) while performing an operation to apply it to all tracks. Hold down both the Shift and Option keys (Macintosh) or Shift and Alt keys (Windows) while performing an operation to apply it to all selected tracks.

To Zoom in or out on any area of a track in the Edit window:

- 1 Click to select the Zoomer.
- 2 Click or drag with the Zoomer to zoom in horizontally for a track or Ruler.

– OR –

Press Option and click or drag with the Zoomer to zoom out horizontally for a track or Ruler.

To zoom in or out incrementally:

- In Pro Tools, click the appropriate Zoom button:
 - Left Arrow (Horizontal Zoom Out)
 - Right Arrow (Horizontal Zoom In)
 - Waveform and MIDI buttons, to increase or decrease vertical zoom of the appropriate track type (audio or MIDI)

Pro Tools also provides five Zoom preset buttons. You can use these to immediately return to established zoom levels; you can define the magnification level for each preset, on a session-by-session basis.

To use a stored Zoom preset:

- Click the appropriate Zoom preset 1–5.

To store a new Zoom preset definition:

- Command-click (Macintosh) or Control-click (Windows) a Zoom preset number to store the current horizontal and vertical Zoom to that preset.

Using Memory Locations for Zoom Control

Pro Tools Memory Locations let you store many attributes with each marker or memory location, including Track Height and Zoom Settings. By creating Memory Locations that are neither Markers nor Selections, but have Track Height, Zoom Settings, or other options enabled, you can use Memory Locations to zoom in and out using just the numeric keypad.

For more information on creating memory locations, see “Memory Locations” on page 85.

Importing Audio

Pro Tools lets you import existing audio files from disk. This is very useful if you have audio files already recorded to disk or if you are working with CD-based sample libraries that you want to use in a new session.

To import audio files or regions from disk:

- Choose File > Import Audio to Track to import files and regions to new audio tracks (they will also appear as regions in the Audio Regions List).
 - or –
- Choose Import Audio from the Audio Regions List pop-up menu to import files and regions to the Audio Regions List only.

 For more information on importing audio into sessions, refer to the Pro Tools Reference Guide.

To import a CD audio track:

- 1 Put the source CD into your computer’s CD drive.
- 2 Use a third party software program of your choice to extract audio from the CD.
- 3 In the session, create a new track by choosing File > New Track.



Creating a new stereo audio track

- 4 In the New Track dialog, specify 1 Stereo Audio Track, and click Create.
- 5 Open the Workspace Browser by choosing Windows > Show Workspace. The Workspace Browser is a window where you can find, audition, and manage your audio files.

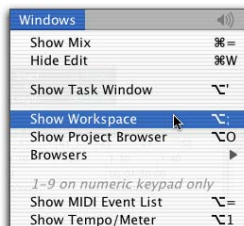

Opening the Workspace Browser

- 6 In the Workspace Browser, navigate to the location where you saved the audio you extracted from your CD in step 2.

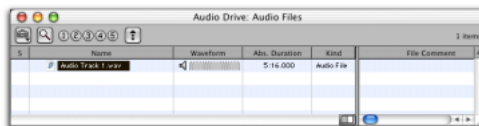

7 You can audition the audio file by clicking on the speaker icon in the waveform window.

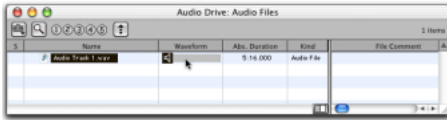

Auditioning an audio file in the Workspace Browser

 If you are running Pro Tools on Mac OS X, you can import audio using the *Movie > Import Audio From Other Movie* command. For more information, see the *Pro Tools Reference Guide*.

 DigiBase provides additional options for importing audio. See the *DigiBase Guide* for more information.

Basic Recording

This section describes how to record audio and MIDI into Pro Tools.

Preparing for Recording

To prepare an audio track for recording:

- 1 Verify the connections to your instruments. Refer to the guide for your audio interface for more information about setting up your studio.
- 2 Choose *File > New Track*, specify 1 Mono Audio Track, and click *Create*.
- 3 In the Mix window, click the Input Selector on the new track.

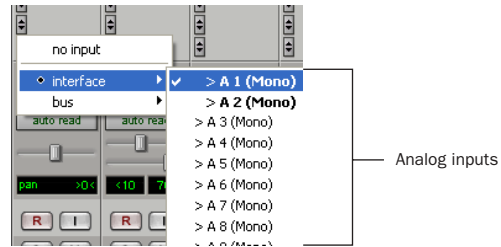

Routing an input to a mono track

4 From the pop-up menu, select the input you want to record. For example, select A 1 if your audio source is plugged into the first analog input on your audio interface. The menu displays the names of the inputs as defined in the I/O Setup dialog.

Setting Levels

Adjust the level of the input at the source (instrument, mic pre-amp, or mixer) to set Pro Tools recording levels. The key to setting proper input levels is to get a signal as loud as possible without creating digital clipping. Signals that get close to the top of the meter in Pro Tools use more of the full bit range (the 16 or 24 bits that make up each audio sample). The more you are able to maximize use of this bit range without clipping, the better your sound quality.

 *Digital clipping occurs when you feed a signal to an audio device that is louder than the circuitry can accept. Watch the meters in Pro Tools while adjusting input levels to prevent clipping.*

Setting Reference Levels

To configure input levels for the 192 I/O:

- 1 In Pro Tools, choose **Setup > Hardware**.
- 2 If using multiple audio interfaces, select an interface in the **Peripherals** list.
- 3 In the **Interface** area, click the **Analog In** tab.

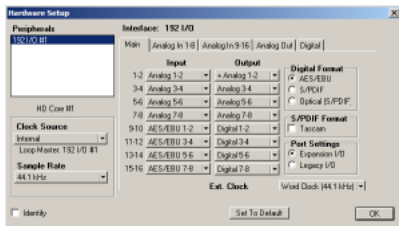

Hardware Setup, 192 I/O Analog In settings

- 4 Set the Reference Level for each Input Channel.
- 5 Click **OK**.

To configure output levels for the 192 I/O:

- 1 In Pro Tools, choose **Setup > Hardware**.
- 2 If using multiple audio interfaces, select an interface in the **Peripherals** list.
- 3 In the **Interface** area, click the **Analog Out** tab.

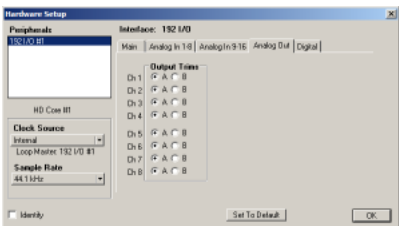

Hardware Setup, 192 I/O Analog Out settings

- 4 Set the Reference Level for each Output Channel.
- 5 Click **OK**.

Recording an Audio Track

To record an audio track:

- 1 Assign the input for a track and set its input levels appropriately.
- 2 Click the **Record Enable** button for a track.
- 3 Choose **Windows > Show Transport** to display the **Transport** window.



Transport window (Expanded view shown)

- 4 Click **Return To Zero** to start recording from the beginning of the session. You can also record according to a selection or from the cursor location in the **Edit** window.
- 5 Click **Record** in the **Transport** window to enable recording.
- 6 Click **Play** or press the **Spacebar** to record on all record-enabled tracks.
- 7 Record your performance.
- 8 Click **Stop** in the **Transport** window or press the **Spacebar** when you are finished recording.

To play back a recorded track:

- 1 Click the track's **Record Enable** button a second time to take it out of **Record** mode.
- 2 Click **Play** in the **Transport** window or press the **Spacebar** to start playback.

3 Click Stop in the Transport window or press the Spacebar to stop playback.

Recording To and From Digital Devices

Using a 96i I/O audio interface, you can digitally transfer up to two tracks at a time to or from any S/PDIF-compatible device. Using a single 96 I/O audio interface, you can digitally transfer as many as eight tracks at a time to or from a digital device (such as an ADAT). You can digitally transfer up to 16 tracks on a single 192 I/O or 192 Digital I/O, up to a system maximum of 96 inputs.

Setting Digital Format and Clock Source

Recording to and from digital devices is only slightly different than analog recording.

Before recording from a digital source, make sure you have enabled the appropriate Clock Source and Digital Format in the Hardware Setup dialog. Digital Format defaults to AES/EBU, meaning your HD I/O will listen to the AES/EBU (Encl) In port for digital clock (if any). If you want to record from a DAT machine connected to your S/PDIF RCA inputs, select S/PDIF Format. If you are using multiple HD interfaces, be sure to configure the appropriate interface in the Hardware Setup dialog.

After enabling a different digital format, appropriate clock signals will become available in the Clock Source selector. If you have multiple interfaces, choose the appropriate clock source on each HD I/O.

Using Pro Tools Output Pairs

Because of the way that outputs function in Pro Tools, each track looks for a stereo output pair. In order to record to eight ADAT tracks, you have to send four pairs of Pro Tools tracks (each pair panned hard left and right) to four pairs of ADAT Optical Digital outputs.

Working with 88.2 kHz or Higher Sample Rates

If the session sample rate is 88.2 kHz or higher, ADAT and TDIF input sources can still be used with Digidesign's 192 I/O, but the sample-rate conversion option must be enabled. 96 I/O and 96i I/O audio interfaces do not have sample rate conversion capability. On the 96 I/O, the ADAT port will go offline with sample rates above 48 kHz. All ADAT and TDIF output ports go offline with sample rates above 48 kHz.

When the sample rate conversion option is disabled, signal does not pass through the sample rate converter.

To enable sample rate conversion on the 192 I/O:

- 1 Choose Setups > Hardware in Pro Tools.
- 2 From the Peripherals list, select the primary 192 I/O audio interface.
- 3 Click the Digital tab.
- 4 Select an Input Format (AES/EBU 1–8, ADAT 1–8, or TDIF 1–8).
- 5 Enable the SR Conversion option for channel pairs.

Recording to and from an ADAT

The 192 I/O and 192 Digital I/O each provide 16 channels of ADAT input and output (eight on the chassis, eight on the digital card). These inputs and outputs are numbered 9–16 and 17–24 by default in the Pro Tools Hardware Setup and I/O Setup dialogs.

The 96 I/O provides eight channels of ADAT input and output. These inputs and outputs are labeled Optical 1–8 and ADAT 1–8 by default in the Pro Tools Hardware Setup and I/O Setup dialogs.

(The 96i I/O does not support ADAT Optical input or output.)

To record ADAT tracks into Pro Tools:

- 1 Connect the Optical Out connector from your ADAT deck to the Optical In connector on the back of your Pro Tools|HD audio interface.
- 2 Open or create a session in Pro Tools.
- 3 Record enable up to eight audio tracks.
- 4 For each track, click its Input Selector and assign Inputs 9–16 to your eight tracks.

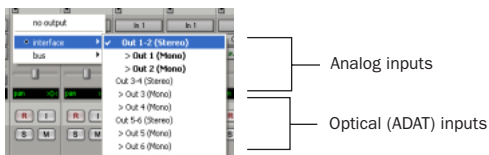

Routing an Optical input pair to a stereo track

- 5 Verify that Pro Tools is synchronized to Optical in the Hardware Setup dialog, and that the Optical Format is set to ADAT.
- 6 Click Record in the Transport window.
- 7 Click Play in the Transport window to begin recording, then press Play on the ADAT.

8 When playback from the ADAT tape is finished, click Stop in the Transport window, or press the Spacebar.

To record Pro Tools tracks to an ADAT:

- 1 Connect the Optical Out connector on your Pro Tools|HD audio interface to the Optical In connector on the back of the ADAT deck.
- 2 Open the session you want to record to ADAT.
- 3 Record-enable up to eight tracks on the ADAT.
- 4 On the ADAT, enable Digital In.
- 5 In Pro Tools, pan the four pairs of tracks you want to record to ADAT so that each pair is panned hard stereo (one track of each pair is panned all the way left, and the other is panned all the way right).
- 6 Route each track pair to a separate Optical output pair by selecting from the Output pop-up menu for each track.
- 7 Verify that Pro Tools is synchronized to Internal in the Hardware Setup dialog.
- 8 Start recording on the ADAT, then click Play in the Pro Tools Transport window. When playback is complete, stop both systems.

Recording MIDI

To configure a MIDI track for recording:

- 1 For Macintosh systems, choose MIDI > Input Devices and make sure your input device is selected in the MIDI Input Enable window. Click OK to apply your changes.

2 Choose File > New Track and specify 1 MIDI Track, then click Create.

3 In the Mix window, click the track's MIDI Device/Channel Selector and choose the destination (assignment) for that MIDI track by choosing a MIDI interface port, a channel, or a device from the pop-up menu. Choices vary depending on the operating system, Pro Tools version, and the hardware and instruments you have connected.

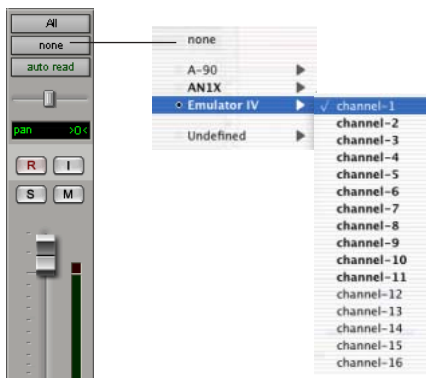

MIDI Device/Channel Selector

4 You can assign a default program change to the track by clicking the Program button in the Mix window and making the necessary selections for program and bank select, and then clicking Done. Default program changes are sent when playing a track.

5 In the Mix window, record-enable the MIDI track.

6 Make sure MIDI > MIDI Thru is selected, then play some notes on your MIDI controller. The MIDI instrument assigned to the track should sound, and the track's meters should register MIDI activity.

To record onto a MIDI track:

1 Verify that the MIDI track you want to record to is record-enabled and receiving MIDI.

2 In the Transport window, click Return To Zero to start recording from the beginning of the session. You can also record according to a selection or from the cursor location in the Edit window.

3 Click Record in the Transport window.

4 Click Play in the Transport window or press the Spacebar to begin recording.

– or –

If using Wait for Note, the Play, Record, and Wait for Note buttons flash. Recording begins when the first MIDI event is received.

– or –

If using Countoff, click Play. The Record and Play buttons flash during the Countoff, then recording begins.

5 Play your MIDI instrument.

6 When you have finished recording, click Stop in the Transport window, or press the Spacebar. The newly recorded MIDI data appears as a MIDI region on the track in the Edit window, as well as in the MIDI Regions List.

To play back a recorded MIDI track:

1 Click the Record Enable button to take the MIDI track out of Record mode.

2 In the Transport window, click Return To Zero to play back from the beginning of the track. You can also play back according to a selection or from the cursor location in the Edit window.

3 Click Play in the Transport window to begin playback. The recorded MIDI data plays back through the track's assigned instrument and channel.

Monitoring MIDI Instruments Without a Mixer

To monitor your MIDI instrument's analog output, you can use an Auxiliary Input. Auxiliary Inputs function as inputs for both internally bussed signals and external audio sources.

To configure an Auxiliary Input for MIDI monitoring:

- 1 Connect the MIDI instrument's audio output to the appropriate inputs on your audio interface.
- 2 Choose File > New Track and specify 1 mono or stereo Auxiliary Input, then click Create.
- 3 Click the Input selector of the Auxiliary Input channel and choose the input to which your MIDI instrument is connected.
- 4 Click the Output selector of the Auxiliary Input channel and choose an output.
- 5 Adjust the level of the Auxiliary Input with its volume fader.

Editing

Pro Tools provides several tools for editing audio and MIDI. In the Edit window, audio and MIDI tracks can be edited into regions or repeated in different locations, to create loops, re-arrange sections or entire songs, or to assemble tracks using material from multiple takes.

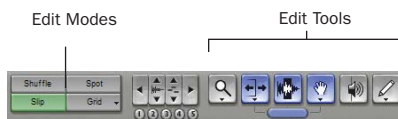

Edit modes and tools (Slip mode, Smart Tool enabled)

Audio and MIDI editing are typically used to:

- Fix or replace mistakes.
- Re-arrange songs and projects.

- Clean up track timing and rhythm by aligning hits to Grid values like bars and beats, time code, or other timebases.
- Create final tracks using selections from multiple takes (also known as a *comp tracks*).

Edit Modes

Pro Tools has four Edit modes: Shuffle, Slip, and Grid. The Edit mode is selected by clicking the corresponding button in the upper left of the Edit window.



Edit mode buttons

 Press F1 (Shuffle), F2 (Slip), F3 (Spot), and F4 (Grid) to set the Edit mode.

The Edit mode affects the movement and placement of audio and MIDI regions (and individual MIDI notes), how commands like Copy and Paste function, and also how the various edit tools (Trimmer, Selector, Grabber, and Pencil) work.

 *Pro Tools 6 provides two Grid modes, Absolute (standard Pro Tools Grid mode), and Relative. For detailed descriptions of Edit modes, refer to the Pro Tools Reference Guide.*

Edit Tools

Pro Tools has seven Edit tools: Zoomer, Trimmer, Selector, Grabber, Scrubber, Pencil, and Smart Tool. Select an Edit tool by clicking it in the Edit window. The Zoomer, Trimmer, Grabber, and Pencil tools have multiple modes, which you can select from a pop-up menu when you click the tool.

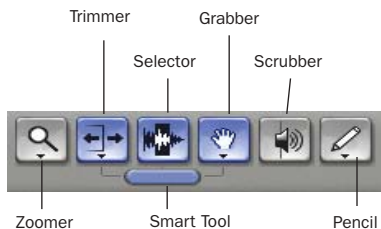

Edit tools in Edit window

 Press the **Escape** key to toggle through the Edit tools.

 For detailed descriptions of the Edit Tools, refer to the *Pro Tools Reference Guide*.

Editing Regions

The Edit tools in Pro Tools are used to edit regions in the Edit window.

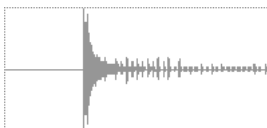

Audio region

Trimming Regions

After recording an audio track, you will have an audio region on that track. If there is some silence at the beginning of the region, or there is some extra audio at the end of the region, you can use the Trimmer tool in Slip mode to shorten the beginning or end of the region.



Audio region on a track

To trim an audio region:

- 1 Select Slip mode.
- 2 Select the Trimmer tool.
- 3 Move the cursor near the beginning of the audio region (notice the cursor changes to a “[”).



Trimming the beginning of a region

- 4 Click at the beginning of the region and drag right to shorten the region.

- 5 Move the cursor near the end of the audio region (notice the cursor changes to a “]”).



Trimming the end of a region

6 Click at the end of the region and drag left to shorten the region.



The trimmed region

You can also extend a region using the Trimmer tool if there is audio data beyond the current boundaries of a region. If extending the region's beginning, drag to the left; if extending the region's end, drag to the right.

Arranging Regions

There are many ways to edit and arrange regions; the following example demonstrates how you might create and arrange a drum loop to compose a rhythm track.

To create and arrange a rhythm sequence:

- 1 Open or create a session in Pro Tools.
- 2 Specify the session meter (MIDI > Change Meter) and tempo (MIDI > Change Tempo).
- 3 Select Grid mode.
- 4 Prepare to record using a MIDI click (see "Saving Sessions" on page 79).
- 5 Record a drum track (see "Recording an Audio Track" on page 89) keeping in mind that you want to use only the best bar (measure). Your recording should fit the grid at the specified tempo and meter.

– or –

Import an existing audio file, such as a drum loop from a sample library, and place it on an audio track (see "Importing Audio" on page 87).

6 Click the Selector tool, then drag on the waveform with the Selector to make a one-bar selection. Note that the selection snaps to the specified grid.

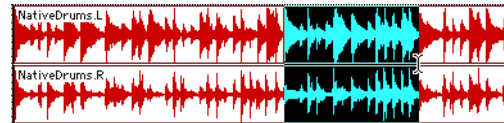

Making a selection in Grid mode

- 7 Create a new audio track (File > New Track).
- 8 From the Grabber pop-up menu, select the Separation Grabber tool.
- 9 With the Separation Grabber tool, drag the selection to the beginning of the new audio track. A new region is created and appears at the beginning of the new track.

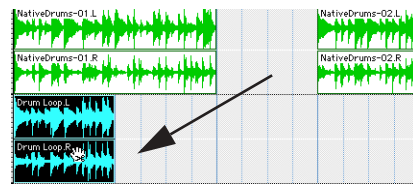

Dragging a selection with the Separation Grabber tool

- 10 With the new region still selected, choose Edit > Repeat.



Repeat dialog

- 11 In the Repeat dialog, enter a number of repeats, and click OK.

You now have a new rhythm track with a "looped" (repeated) phrase. You can use these editing tools to do much more advanced and involved editing of regions. For example, you

could separate beats or “hits” into individual regions and rearrange them in Grid or Shuffle mode as a way of coming up with new and interesting rhythms.

Playlists and Non-Destructive Editing

Playlists let you create and retrieve multiple versions of track edits. A playlist can be a complete take, an overdub, or an arrangement of selections from multiple takes. You can duplicate playlists to save edits in their current state, then continue making additional edits to the new playlist knowing you can always go back to the previous version.

To create multiple playlists for editing:

- 1 Start with a track on which you want to try different edits.
- 2 From the Playlist Selector pop-up menu, choose Duplicate.



Playlist Selector
Popup Menu

Playlist Selector Popup Menu

- 3 Name the duplicated playlist and click OK.
- 4 Make your first series of edits.
- 5 Return to the original playlist by selecting it from the Playlist Selector pop-up menu.
- 6 Repeat steps 2–5 for any further edits.

In this way, you can try out different edits of a track, and switch back and forth between playlists for comparison.

Mixing

The Pro Tools mix environment provides many familiar channel strip controls for setting volume, pan, solo, and mute. Mixer and I/O controls can be shown in both the Mix and Edit windows.

To view the Mix window:

- Select Windows > Show Mix.

 Press *Command+Equals (=)* on Macintosh, or *Control+Equals (=)* in Windows to switch between the Edit and Mix windows.

Using Channel Strip Controls

Volume Increase or decrease the track level by dragging its Volume fader up or down.

Pan Pan a track left or right in the mix by dragging its Pan slider left or right.

Solo Solo a track (muting all other tracks) by clicking its Solo button.

Mute Mute a track by clicking its Mute button.

Basic Signal Routing

Signal routing is accomplished by assigning track inputs and outputs. Audio track inputs can be from any hardware input or bus path. Once recorded, an audio track's input is its audio file on disk. Auxiliary Inputs can be any hardware input or internal bus path. For all types of audio tracks, outputs can be routed to any hardware output or internal bus path.

Together, these signal routing features let you set up virtually any mixer architecture for your projects, including submixing, sends and returns for effects processing, and multichannel mixing for surround.

Send and Return Submixing for Effects Processing

When you are submixing for reverb, delay, and similar effects processing, you can use sends and Auxiliary Inputs to achieve traditional send/return bussing. You can use a real-time plug-in (see “Plug-Ins” on page 99) or a hardware I/O insert (see “Connecting Effects Units” on page 73) as a shared resource for all tracks included in a submix. The wet/dry balance in the mix can be controlled using the track faders (dry level) and Auxiliary Input fader (wet, or effect return level).

Creating a Send

Pro Tools provides up to five sends per audio track. A send can be mono or stereo, routing to an output or one of 64 internal bus paths.

To assign a send on a track:

- 1 Make sure Sends View is enabled in the Mix window (Display > Mix Window Shows > Sends View).
- 2 Click the Sends button on an audio track and choose a bus path from the pop-up menu.

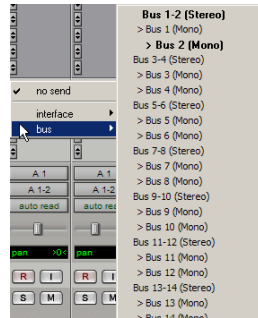

Assigning a send to a stereo bus path

- 3 Set the output level of the send. You can set the send level to zero by Option-clicking (Macintosh) or Alt-clicking (Windows) the send fader.



You can configure the default level for new sends to be $-\infty$ or at unity gain (0 dB) by enabling or disabling the Sends Default To “ $-\infty$ ” option under the Operation Preferences.

Creating a Return

Auxiliary Inputs can be created to act as return channels for busses, as well as for inputs from hardware sources.

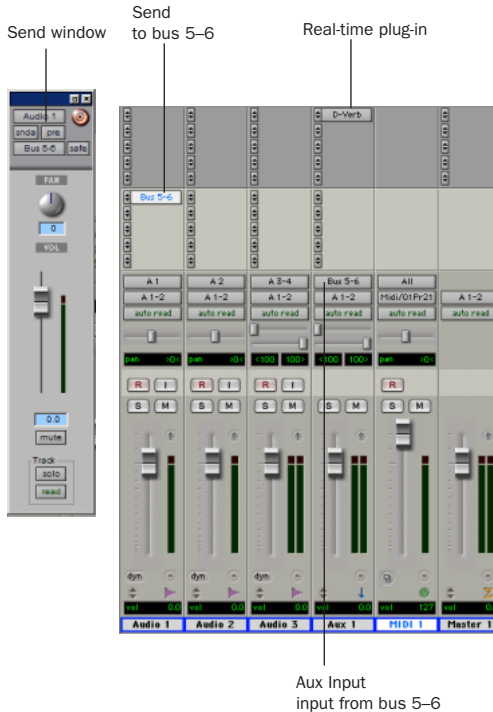

Audio and Auxiliary Input tracks configured for a send and return

To create a return:

- 1 Choose File > New Track and specify 1 mono or stereo Auxiliary Input, then click Create.
- 2 Click the Input Selector of the Auxiliary Input and set it to the bus path you assigned to the sends on the source tracks.
- 3 Click the Output Selector of the Auxiliary Input and choose an output path.

Master Faders

Master Faders are used as output and bus masters, and can control any mono, stereo or multi-channel output or bus path in a session. You can then use the controls on the Master Fader to control the volume, solo and mute, or apply inserts to those paths.

When you are mastering your final mix, it is recommended that you use a dither plug-in on the Master Fader controlling your main outputs (see “Using Dither on Mixdown” on page 101).

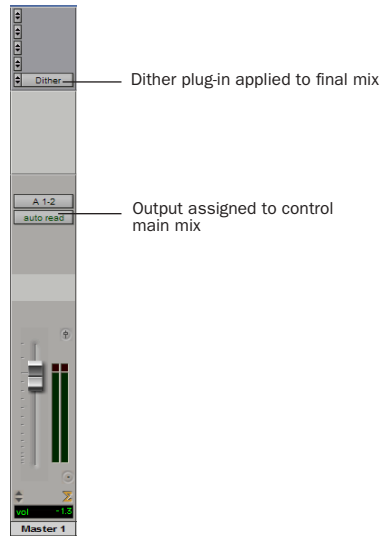

Master Fader controlling main outputs

To create a Master Fader:

- 1 Choose File > New Track and specify 1 mono or stereo Master Fader track, then click Create.
- 2 In the Mix window, click the Master Fader's Output Selector and choose the output path that you want to control. You can choose either outputs or internal busses.

To use a Master Fader as a master stereo volume control for all tracks in a session:

- 1 Choose File > New Track and specify 1 stereo Master Fader track, then click Create.
- 2 Set the outputs of all audio tracks in the session to outputs 1–2 and set the panning of each track.
- 3 Set the output of the Master Fader to your main output path (outputs 1–2).

Plug-Ins

Plug-ins provide EQ, dynamics, delays and many other types of effects processing.

Plug-ins function either in real time or in non-real time. TDM and RTAS plug-ins are non-destructive effects, which are inserted on tracks to process audio in real time—just like an external hardware processor (during playback). AudioSuite plug-ins, on the other hand, are destructive effects that process audio files on disk in non-real time.

Real-time plug-ins are assigned to tracks from the Inserts view in the Mix or Edit windows. Once assigned to a track, plug-ins appear in the track's Inserts view, and can be opened by clicking on the Insert button.

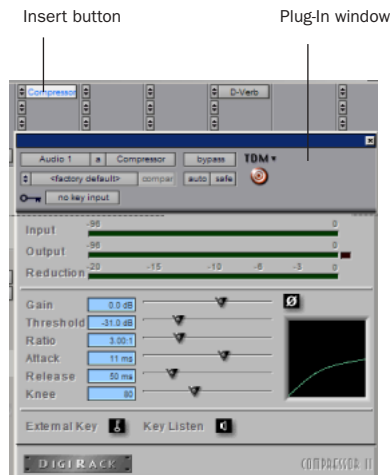

Compressor plug-in

To insert a real-time plug-in on a track:

- 1 Make sure the Inserts View is shown in the Mix or Edit window.
- 2 Click the Insert Selector on the track and select the plug-in that you want to use.

Pro Tools comes with a complete set of DigiRack plug-ins, and many more are available from Digidesign and our Development Partners.

 For more information about plug-ins, see the *DigiRack Plug-Ins Guide*, the *Digidesign Plug-Ins Guide*, and the *Plug-Ins* chapter of the *Pro Tools Reference Guide*.

Mix Automation

Mix automation lets you record, or *automate*, changes to track and send levels, mutes, pan, and plug-in parameters. MIDI tracks provide volume, pan, and mute automation only.

To write automation:

- 1 In the Automation Enable window (Windows > Show Automation Enable), enable an automation *type* (volume, pan, mute, send level, send pan, send mute, or any plug-in automation).
- 2 Select an automation *mode* for the tracks to be automated (Write, Touch, Latch, or Trim mode).
- 3 Start playback and begin writing automation by adjusting faders and other controls during playback. Pro Tools remembers all moves performed on enabled parameters.

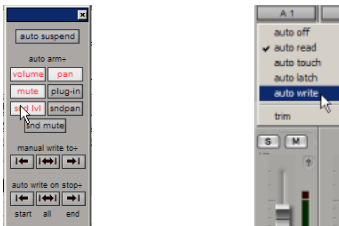

Enabling automation (left) and choosing a track Automation mode (right)

Once written, automation can be re-written or displayed and edited graphically in the Edit window.

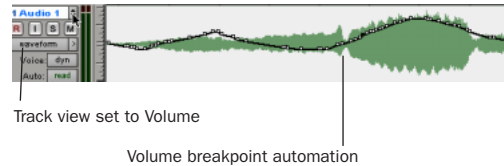

Volume automation in a track in the Edit window

 For more information on using automation, see the *Pro Tools Reference Guide*.

Mixing with a Control Surface

Rather than mixing with a mouse—adjusting one fader at a time—you might find using a MIDI control surface (such as Motor Mix from CM Labs) or an Ethernet control surface (such as ProControl or Control|24) for mixing to be much more effective.

 For more information on using a MIDI Control Surface, see the *MIDI Control Surfaces Guide*. For more information on using ProControl or Control|24, see their guides.

Final Mixdown

The Bounce to Disk command lets you write a final mix to disk, create a new loop, print effects, or bounce any submix. Once you have bounced your final mix to disk, you can use another program to burn the resulting file to Compact Disc.



Pro Tools lets you choose from a variety of formats when you Bounce to Disk (such as .WAV). See the Pro Tools Reference Guide for more information.

When you bounce a track to disk, the bounced mix includes the following:

Audible Tracks All audible tracks are included in the bounce. Any muted tracks do not appear in the bounce. If you solo a track or region, only the soloed elements appear in the bounced mix.

Automation All read-enabled automation is played back and incorporated in the bounced mix.

Inserts and Sends All active inserts, including real-time plug-ins and hardware inserts, are applied to the bounced mix.

Selection or Track Length If you make a selection in a track, the bounced mix will be the length of the selection. If there is no selection in any track, the bounce will be the length of the longest audible track in the session.

To Bounce to Disk:

- 1 Choose File > Bounce to Disk.
- 2 Select any mono, stereo, or multichannel output or bus path as the source for the bounce.
- 3 Select the File Type (such as WAV), Format (such as mono or stereo), Resolution (such as 16-bit), and Sample Rate (such as 44.1 kHz).
- 4 Click Bounce.

Using Dither on Mixdown

You should use a dither plug-in when using the Bounce To Disk command, or when mastering to an external device. Bounce to Disk does *not* automatically apply dither. To dither a bounce file, insert an included Digidesign Dither plug-in, or another dither plug-in, on a Master Fader assigned to the bounce source path. Master Faders are often preferable to Auxiliary Inputs because Master Fader inserts are post-fader (which is better for dither applications).



For more information on using dither, refer to the Pro Tools Reference Guide.

appendix a

Connecting SCSI Drives

SCSI hard drives are the recommended recording media for Pro Tools TDM systems on Windows, and can also be used with Pro Tools on Macintosh.

Although Pro Tools will let you record to your system drive, this is generally not recommended. Performance for recording and playback on system drives is sometimes worse than on non-system drives, resulting in lower track counts and fewer plug-ins.

▲ *Be aware that recording to your system drive can quickly use up available hard drive space. This can negatively affect system stability and the performance of all applications including Pro Tools.*

For the most current information on hard drive requirements and recommendations, see the compatibility pages on the Digidesign Web site (www.digidesign.com/compato).

SCSI Requirements

For maximum recording and playback performance, Digidesign recommends qualified SCSI hard drives and a qualified SCSI host bus adapter (HBA) card or (on Windows systems) a qualified built-in SCSI HBA connector on the motherboard.

SCSI drives must provide a data transfer rate of at least 9 MB per second of sustained throughput.

Visit the Digidesign Web site (www.digidesign.com) for a list of qualified SCSI hard drives and SCSI HBA cards:

▲ *Software RAID is not supported for audio drives.*

SCSI Cables

Use shorter SCSI cables to improve reliability. Table 1 provides guidelines for maximum cable lengths according to SCSI type.

In the following table, the maximum cable length includes all cables used in the chain, not just point-to-point connections.

Table 1: Maximum cable length and number of drives supported according to SCSI type

SCSI type and transfer rate	maximum cable length	maximum # of drives
Fast SCSI 10 MB/sec	3 meters	8
Wide SCSI 20 MB/sec	3 meters	16
Ultra SCSI 20 MB/sec (8-bit narrow)	3 meters	5
Ultra SCSI 40 MB/sec (16-bit wide)	3 meters	5
Ultra SCSI 20 MB/sec (8-bit narrow)	1.5 meters	6–8
Ultra SCSI 40 MB/sec (16-bit wide)	1.5 meters	6–8
Ultra2 SCSI Low Voltage Dif- ferential (LVD) 80 MB/sec	1.2 meters	16

Disk Space for Audio Tracks

A single mono audio track recorded at 24-bit resolution at a CD-fidelity sampling rate of 44.1 kHz requires about 7.5 MB of hard drive space per minute. The same track recorded at

16-bit resolution requires about 5 MB per minute. Stereo tracks require about twice as much hard drive space. Sample rate also affects hard drive requirements.

Using these guidelines:

- 192 mono tracks of 44.1/48 kHz, 24-bit audio takes up about 1453 MB (44.1 kHz) or 1584 MB (48 kHz) of hard drive space per minute.
- 128 mono tracks of 44.1/48 kHz, 24-bit audio takes up about 969 MB (44.1 kHz) or 1055 MB (48 kHz) of hard drive space per minute.
- 128 mono tracks of 44.1/48 kHz, 16-bit audio takes up about 646 MB (44.1 kHz) or 703 MB (48kHz) of hard drive space per minute.
- 64 mono tracks of 88.2 or 96 kHz, 24-bit audio takes up about 969 MB (88.2kHz) or 1055 MB (96kHz) of hard drive space per minute.
- 64 mono tracks of 88.2 or 96 kHz, 16-bit audio takes up about 646 MB (88.2 kHz) or 703 MB (96kHz) of hard drive space per minute.
- 24 mono tracks of 176.4 or 192 kHz, 24-bit audio takes up about 727 MB (176.4kHz) or 791 MB (192kHz) of hard drive space per minute.

Distribute Audio Across Multiple Drives

For best recording and playback performance, don't record and play back all audio files in a session from the same drive. Instead, use Pro Tools Disk Allocation features to distribute audio files between multiple drives. See the *Pro Tools Reference Guide* for details.

Separate Video and Audio Files

If you are working with QuickTime, movie files must reside on a different SCSI bus than audio files. If audio files reside on disks connected to a SCSI HBA card, video data should reside on drives connected to a different SCSI bus.

Dual-Channel SCSI HBA Cards

If you use a dual-channel SCSI HBA card, allocate audio files equally to drives connected to each of the two busses on the card for optimal performance.

If using video files, make sure to put your video files on one bus and audio files on the other bus.

Connecting SCSI Drives

To connect an external SCSI drive:

- 1 Turn off power to both the computer and the hard drive.
- 2 Attach a SCSI cable from the SCSI port of the hard drive to the SCSI port of the SCSI HBA card or computer.
- 3 Secure the cable's connectors to the hard drive and computer.
- 4 Connect additional drives by daisy-chaining from one drive to another. Keep cable lengths to a minimum (see Table 1).

5 Verify that the last SCSI device in the chain is properly terminated. (See "SCSI Termination" on page 106.)

6 Attach power cables to the hard drives.

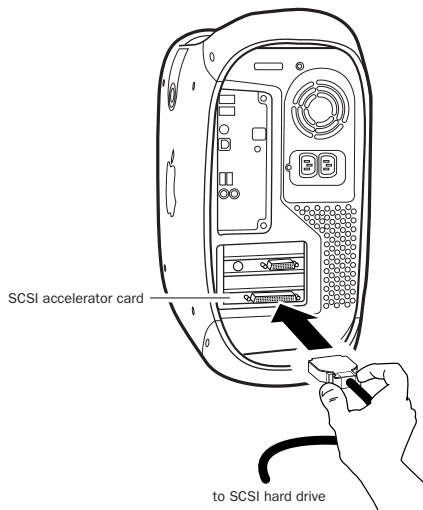

Connecting a SCSI cable to a SCSI HBA card

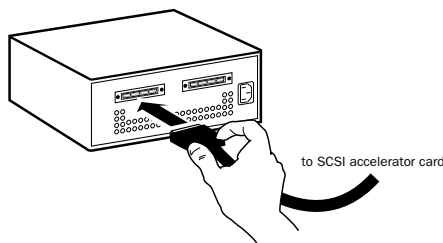

Connecting an external SCSI hard drive

SCSI Termination

Your computer's SCSI chain must be properly terminated or your system will not function correctly. Only the last device on the chain should be terminated using the termination type recommended by the hard drive manufacturer.

The drive should use either an external terminator plug or have its internal terminators enabled. If you are using a terminator plug, Digidesign recommends that you purchase and use an *active* terminator.

▲ *Do not enable internal termination and install an external terminator plug on the same drive. This will cause SCSI errors. See your hard drive's documentation for information on which type of termination it uses.*

Quick Formatting SCSI Drives

Macintosh Requirements

On Macintosh systems, SCSI hard drives used for audio recording on TDM systems must be formatted (or initialized) for either the HFS+ or HFS file system (HFS+ is recommended). Drive partitions of up to 2 terabytes (2000 gigabytes) can be used.

TDM systems require that you use the Apple Disk Utility for all drive formatting and partitioning. Only one disk utility should be used for all drives in a system.

Windows Requirements

SCSI hard drives used for audio recording on TDM systems must be formatted for the FAT32 or NTFS file system. Under Windows 2000 and Windows XP, NTFS drive partition sizes are almost limitless, whereas FAT32 drive partitions have a limit of 32 GB.

TDM Windows systems require that you use Microsoft Windows Disk Administration software for drive formatting and partitioning. Use only one disk utility for all drives in a system.

Initializing a Macintosh Drive

To initialize a new Macintosh drive:

- 1 Turn on your hard drives, computer, and any other peripherals.
- 2 Use the Apple OS X Disk Utility to initialize and partition any new hard drives.



For details on using disk formatting utilities, refer to their online documentation.

Initializing a Windows Drive

To format a new Windows drive:

- 1 Turn on your hard drives, computer, and any other peripherals.
- 2 Use Microsoft's Disk Management software, located in the Administrative Tools Control Panel under Computer Management > Storage.

Refer to your Windows documentation or help for information on how to use the Disk Management software.

General Hard Drive Maintenance

 *If using Macintosh drives on Windows systems, refer to “Using Macintosh Drives on Windows Systems” on page 109.*

Formatting Drives

There are two different types of formatting: high-level formatting and low-level formatting.

 *Digidesign does not recommend low-level formatting.*

High-Level Formatting (Initialization)

High-level formatting, or *initializing* a drive replaces the drive’s directory, volume partition map and drivers. Information about the drive is created and drivers that communicate this information to the host CPU are installed. The drive itself is not erased, nor is verification performed.

When is High-Level Formatting Necessary?

It is generally necessary to high-level format a hard drive in one of the following cases:

- ◆ If a new drive is being prepared for use on a computer for the first time and the drive is not already high-level formatted.
- ◆ If you suspect that the directories containing the drive’s information have become corrupted.
- ◆ If a drive is being changed from one platform to another. For example if you are switching from a Macintosh to a Windows-based system, or from a Windows to a Macintosh-based system, the drive must be high-level re-formatted for the new operating system.

Low-Level (Physical) Formatting

Low-level formatting means completely erasing the hard drive and rewriting each sector address on the drive. In low-level formatting, the sector and track addresses, error-correction codes, and other details are written on the platters of the hard drive in the form of a magnetic pattern. A low-level format permanently erases all data on the drive.

When is Low-Level Formatting Necessary?

Virtually all hard drives come pre-formatted from the manufacturer. Low-level formatting is generally unnecessary except in rare circumstances. They are:

- ◆ If you want to change the Block Size of the drive. This is not recommended by Digidesign. Digidesign systems only recognize 512-byte blocks.
- ◆ If you want to perform permanent deletion of data.
- ◆ If you want to clean a drive that is being migrated from one operating system to another (for instance, from UNIX to Macintosh).

Should you decide low-level formatting is necessary, keep in mind that it can take up to three hours or more (depending on the size of the drive). Avoid power interruptions and computer bus resets during the format operation or permanent damage to the drive could occur. In addition, leave the drive powered on for at least 30 minutes prior to formatting so that the drive has time to make any necessary thermal adjustments or recalibrations.

Partitioning Drives

Partitioning divides a physical drive into multiple, unique volumes, almost as if you were creating virtual hard drives. Partitioning is usually performed when the drive is high-level formatted (Macintosh) or initialized (Windows).

⚠ *Mac OS allows drives larger than 4096 MB to be seen as whole volumes. Drives must be initialized with a disk utility that recognizes the 2 terabyte limit. Single Pro Tools audio files cannot exceed 2048 MB in size.*

⚠ *Windows XP allows drives formatted with the NTFS or FAT32 file systems to be seen as whole volumes. Single Pro Tools audio files cannot exceed 2048 MB in size.*

Seek Times on Partitioned Drives

Seek times are actually faster on partitioned drives (assuming that reads and writes are performed on a single partition), since the heads only have to seek within the partition boundaries, rather than the whole capacity of the drive.

Smaller partitions perform faster than larger partitions, but this comes at the expense of contiguous storage space. When you partition a drive, you will need to find the compromise that best suits your performance and storage requirements.

⚠ *Avoid distributing audio files within a session over different partitions on the same drive since this will adversely affect drive performance.*

Avoiding File Fragmentation

For maximum recording and playback efficiency, data should be written to your hard drive in a contiguous fashion—minimizing the seek requirements to play back the data. Unfortunately, your computer can't always store the sound files in this way and must write to disk wherever it can find space.

In multitrack recording, audio tracks are written in discrete files, spaced evenly across the disk. While fragmentation of individual files may be zero, the tracks may be far enough apart that playback will still be very seek-intensive. Also, the remaining free space on the disk will be discontinuous, increasing the likelihood of file fragmentation on subsequent record passes.

Increased fragmentation increases the chance of disk errors, which can interfere with playback of audio, and result in performance errors.

💡 *On Windows, to avoid fragmentation, format drives with higher cluster sizes (such as 32K).*

⚠ *On Macintosh, if Norton Utilities is used, it must be Norton Utilities v4.0 or later to ensure compatibility with HFS+ drives.*

Optimizing (Defragmenting) Drives

To prevent fragmentation, you can optimize your drive, which rearranges your files into a contiguous format. Most optimizing software lets you run a check on a drive to find out the percentage of fragmentation. If your drive shows moderate to heavy fragmentation, you should consider optimizing it.

If you use your system for intensive editing, or if you frequently delete audio or fade files from your hard drive, you may need to optimize your drives on a weekly basis, or even every few days, since it doesn't take long for even a large hard drive to become fragmented.

Backing Up Data Before Optimizing

Since your files will be rewritten by the optimization process, always make a backup copy of the data on your hard drive before you optimize it. You should also use a hard drive utility to find and repair any problems before optimizing data or re-initializing your drives. If there is any damage to your hard drive's directories prior to optimizing, serious data loss may result.

Using Macintosh Drives on Windows Systems

Pro Tools for Windows lets you record and play back sessions directly from a Macintosh-formatted (HFS or HFS+) drive connected to a Windows system. This functionality requires that all Macintosh session and audio files be stored on Macintosh-formatted drives.

To mount HFS or HFS+ drives on a Windows system, you must use the MacOpener™ software utility by DataViz. An installer for the demo version of MacOpener is included as an installation option for Pro Tools.

 *For details on sharing sessions between Macintosh and Windows systems, see the Pro Tools Reference Guide.*

Installing the MacOpener Utility

To Install MacOpener:

- 1 Quit Pro Tools if it is open.
- 2 Locate the macopener executable (.exe) file in the above location and double-click it to launch the installer.
- 3 Follow the on-screen instructions to install MacOpener.
- 4 When installation is complete, restart your computer.

Enabling the MacOpener Driver

When you are finished installing MacOpener, the MacOpener driver must be enabled to mount HFS and HFS+ drives.

To enable the settings on the MacOpener Driver:

- 1 Choose Start > Programs > MacOpener > MacOpener Driver Preferences.
- 2 Under Driver Settings, select Enable MacOpener Driver.
- 3 Under Extension Mapping, select Do not add the PC extension to the Mac file name.

Mounting HFS Drives

If the MacOpener utility is installed and enabled, no additional steps are required to mount HFS drives. They appear as normal system drives after you connect them and restart your computer.

Formatting and Maintaining HFS and HFS+ Drives

Although you can use MacOpener to format HFS and HFS+ drives from a Windows machine, this is not recommended for use with Pro Tools. We recommend that you connect the drives to a Macintosh computer (if possible) and use the ExpressStripe software from ATTO, included on the Macintosh Pro Tools Installer CD-ROM.

appendix b

DigiTest Error Codes

For the latest version of DigiTest, visit the Digidesign Web site (www.digidesign.com).

DigiTest Error Codes

Code	Description
Err3	Cards from different Pro Tools systems are incorrectly mixed. See the configuration chapters.
Err4	Cards marked with this error are installed in the wrong order. See the configuration chapters.
Err5	Too many cards of this type are installed in the system. Refer to the Digidesign Web site for compatibility information.
Err6	A card is installed in a reserve slot. For example, a Digidesign card is installed in the slot reserved for the Expansion Chassis Host Interface card. Refer to the configuration chapters, as well as related installation guides.
Err1220	SCSI Accelerator card is installed in the wrong slot. See the configuration chapters for correct location of the card.
Err1221	Expansion Chassis Host Interface card is installed in the wrong slot. See Expanded Systems Guide for correct location of the card.

Windows System Optimizations

When installing Pro Tools on Windows XP, there are many system variables that affect performance. If you have followed all the Windows configuration instructions in Chapter 2, “Windows Configuration” and are still experiencing problems, try the following troubleshooting suggestions.

 *Norton Ghost is highly recommended, as it lets you save your system in a working state and easily revert to that state should you accidentally disable anything that your computer needs.*

Troubleshooting

Blue Screen at Startup

If, after installing Pro Tools and QuickTime, your computer crashes with a blue screen, use Add/Remove Programs to uninstall Pro Tools and QuickTime. Then, repeat the installation instructions in “Installing Pro Tools Software” on page 23.

Advanced Settings

The following system optimizations may help Pro Tools perform better on some systems. It is recommended that you only try these optimizations if necessary, as they may disable or adversely affect the functionality of other programs on your system.

Disabling Network Cards

If applicable, disable any networking cards (other than a 1394 “FireWire” card that you might use to connect an external drive to your system).

To disable a network card:

- 1 Right-click My Computer and choose Manage.
- 2 Under System Tools, select Device Manager.
- 3 In the Device Manager window, double-click Network adapters, then double-click the Network Adapter card you want to disable.
- 4 Under the General tab, choose “Do not use this device (disable)” from the Device Usage pop-up menu, and click OK.
- 5 Close the Computer Management window.

Processor Scheduling

To Adjust Processor Scheduling Performance:

- 1 Click Performance and Maintenance, then click System.
- 2 Click the Advanced tab.
- 3 Under the Performance section, click the Settings button.
- 4 Click the Advanced tab.
- 5 Under the Processor scheduling section, select the Background Services option.
- 6 Under the Memory Usage section, select the System cache option.
- 7 Click OK twice. You will need to restart your computer for the changes to take effect.

Startup Items

The fewer items in use by your computer, the more resources are available for Pro Tools. Some startup applications may be consuming unnecessary CPU resources, and should be turned off.

Be very careful when disabling startup items, including (but not limited to) the following:

- Portable media serial number (required for applications that utilize a copy protection key)
- Plug and play
- Event log
- Cryptographic services
- DHCP Client, TCP/IP Net BIOS, and other networking-related items (unless the computer has no network or internet connection, in which case these items can be disabled)



Norton Ghost is highly recommended, as it lets you save your system in a working state and easily revert to that state should you accidentally disable anything that your computer needs.

To Disable System Startup Items:

- 1 From the Start menu, choose Run.
- 2 Type “msconfig” and click OK. The System Configuration Utility opens.
- 3 Under the General tab, choose Selective Startup.
- 4 Deselect Load Startup Items and click OK.
- 5 Click Restart to restart the computer.
- 6 After restarting your computer, a System Configuration message dialog is displayed. Check to see if Pro Tools performance has increased before you deselect the “don't show this message again” option. If performance has not changed, run “msconfig” and return your computer Selective Startup back to Normal Startup. Alternatively, try disabling start up items and non-essential processes individually.

Digidesign ASIO Driver (Windows Only)

Introduction

The Digidesign ASIO Driver is a multichannel, multimedia sound driver that allows third-party audio programs that support the ASIO standard to record and play back through Digidesign hardware.



Check the Digidesign Web site (www.digidesign.com) for the latest third-party drivers for Pro Tools hardware, as well as current known issues.

Full-duplex playback of 24- and 16-bit audio are supported at sample rates up to 96 kHz, depending on the Digidesign hardware and ASIO Driver program used.

The Digidesign ASIO Driver will provide up to 18 channels of input and output, depending on your Pro Tools hardware:

- Up to 8 channels of input and output with Pro Tools|HD systems
- Up to 18 channels of input and output with Digi 002 and Digi 002 Rack
- Up to 2 channels of input and output with Mbox

Compatible Software

For a list of ASIO Driver-compatible software, see the compatibility documents available on the Digidesign Web site (www.digidesign.com/compato).

Installing the ASIO Driver

The ASIO Driver is installed by default when you install Pro Tools.

Removing the ASIO Driver

If you need to remove the ASIO Driver from your computer, complete the following steps.

To remove the ASIO Driver:

- 1 Choose Start > Control Panel.
- 2 Double-click the Add or Remove Programs icon.
- 3 From the Currently installed programs list, select Digidesign Pro Tools.
- 4 Click the Change/Remove button.
- 5 Modify your installation by unchecking the Digidesign ASIO Driver option only.

Changing ASIO Driver Settings

Changing ASIO Driver settings is done in your third party ASIO program. Refer to the documentation that came with your software program. For example, with Propellerhead Reason, click on the ASIO Control Panel button (shown below).

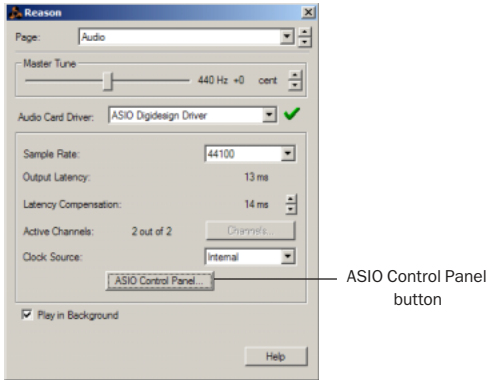

Setup Example, using Propellerhead Reason

ASIO Driver Control Panel

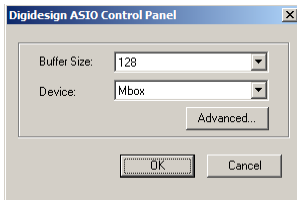

Digidesign ASIO Control Panel

The Digidesign ASIO Driver Control Panel cannot be accessed under the following circumstances:

- When Pro Tools is running.
- When playing or recording in an audio program that does not support the ASIO Driver.
- When using a third-party audio program that has an option to keep the ASIO Driver “open” even when you are not playing or recording. (You must close the audio program before you can open the ASIO Driver Control Panel.)

Buffer Size Control

When you play a file from a client audio program, the client program divides the file into buffers and sends each of these to the ASIO Driver. The ASIO Driver copies the client program’s buffers to your Digidesign hardware’s own buffers in a double-buffering scheme. The Buffer Size control in this dialog allows you to set the size of each of the two buffers the ASIO Driver uses on Digidesign hardware. You may select from the following buffer sizes:

- 128 samples
- 256 samples
- 512 samples
- 1024 samples
- 2048 samples

Small buffers have the advantage of low latency in the record monitor path. Larger buffers have the advantage of making the ASIO Driver more immune to audio dropouts during playback and recording.

In some third-party audio programs, performing various tasks such as maximizing or minimizing windows will interrupt the ASIO Driver and create glitches in the audio. Choosing medium or large buffers (such as 256–1024) can help alleviate this problem.

Changing the Buffer Size for the ASIO Driver does not affect the H/W Buffer Size settings in the Pro Tools Playback Engine dialog.

Device

The Device Type will always be set to your installed Pro Tools hardware.

Advanced Button

The Advanced button opens the Hardware Setup dialog for your Digidesign system.

Digidesign WaveDriver (Windows Only)

Introduction

The Digidesign WaveDriver is a multichannel, multimedia sound driver that allows third-party audio programs that support the WaveDriver standard to play back through Digidesign hardware.



Check the Digidesign Web site (www.digidesign.com) for the latest third-party drivers for Pro Tools hardware, as well as current known issues.



The WaveDriver is not multi-client. Only one application at a time can use the WaveDriver. Be sure to disable the Windows system sounds. It is also recommended that you use a separate sound card for games or other general work. For third-party soft-synthesizer and samplers, use the Digidesign ASIO Driver (refer to the ASIO Driver Usage Guide).

Playback of 24- and 16-bit audio are supported at sample rates supported by the hardware and WaveDriver program used.

The Digidesign WaveDriver will provide up to 18 channels of output, depending on your Pro Tools hardware:

- Up to 8 channels of output with Pro Tools|HD systems
- Up to 18 channels of output with Digi 002 and Digi 002 Rack
- Up to 2 channels of output with Mbox

Compatible Software

For a list of WaveDriver-compatible software, see the compatibility documents available on the Digidesign Web site (www.digidesign.com/compto).

Installing the WaveDriver

The WaveDriver is installed by default when you install Pro Tools.

Removing the WaveDriver

If you need to remove the WaveDriver from your computer, complete the following steps.

To remove the WaveDriver:

- 1 Choose Start > Control Panel.
- 2 Double-click the Add or Remove Programs icon.
- 3 From the Currently installed programs list, select Digidesign WaveDriver.
- 4 Click the Change/Remove button.
- 5 Click OK to remove the WaveDriver.

Configuring WaveDriver for Windows Media Player and Other Third-Party WaveDriver Programs

WaveDriver is configured in the Sounds and Audio Devices Control Panel (for programs that use the Windows Sound Playback Default Device, such as Windows Media Player), or as a preference for third-party WaveDriver programs (such as Sound Forge).

To configure WaveDriver as the Windows Sound Playback Default Device (for example, for Windows Media Player):

- 1 Choose Start > Control Panel.
- 2 In Classic View, launch Sounds and Audio Devices.
- 3 Click the Audio tab.
- 4 Select the Digidesign audio interface in the Sound Playback default device lists.
- 5 Close the Control Panel. When you run Windows Media Player, it automatically output to your Digidesign hardware.

To configure WaveDriver for a third party WaveDriver application:

- In the third-party program, select the Digidesign audio interface as the preference for your playback hardware. Refer to your program's documentation.

appendix f

Digidesign CoreAudio Driver (Macintosh Only)

Introduction

The Digidesign CoreAudio Driver is a multi-channel, multimedia sound driver that allows third-party audio programs that support the CoreAudio standard to record and play back through Digidesign hardware.



Check the Digidesign Web site (www.digidesign.com) for the latest third-party drivers for Pro Tools hardware, as well as current known issues.

Full-duplex playback of 24- and 16-bit audio are supported at sample rates up to 96 kHz, depending on the Digidesign hardware and CoreAudio Driver program used.

The Digidesign CoreAudio Driver will provide up to 18 channels of input and output, depending on your Pro Tools hardware:

- Up to 8 channels of input and output with Pro Tools|HD systems
- Up to 18 channels of input and output with Digi 002 and Digi 002 Rack
- Up to 2 channels of input and output with Mbox

Compatible Software

For a list of CoreAudio Driver-compatible software, see the compatibility documents available on the Digidesign Web site (www.digidesign.com/compato).

Installing the CoreAudio Driver

The Core Auto Driver is installed by default when you install Pro Tools.

Removing the CoreAudio Driver

To uninstall the Digidesign CoreAudio Driver:

- 1 Power on your system.
- 2 On the Pro Tools Installer CD, locate and double-click the Install CoreAudio file.
– or –

From the Digidesign Web site, download and double-click the Install CoreAudio file.

- 3 In the Install CoreAudio window, select Uninstall from the Custom Install pop-up menu.
- 4 When the uninstall is complete, quit the CoreAudio Installer.

Configuring the Digidesign CoreAudio Driver

You can configure the Digidesign CoreAudio Driver using Digidesign CoreAudio Setup, or from within most third-party CoreAudio-compatible client applications (such as BIAS Peak or Logic Audio). Consult the manufacturer's documentation for more information.

Some applications, such as Apple's iTunes or QuickTime Player, also require that you configure either the Apple Sound Preferences or Apple Audio MIDI Setup to use the Digidesign CoreAudio Driver.

Digidesign CoreAudio Setup

Use Digidesign CoreAudio Setup to specify which third-party CoreAudio applications can use the CoreAudio Driver, change the CoreAudio Buffer Size setting, and access the Hardware Setup dialog for your Digidesign hardware. Digidesign CoreAudio Setup also identifies your Digidesign hardware and the supported number of Input and Output Channels.

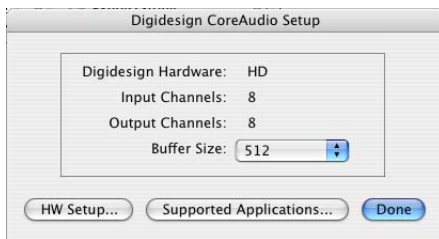

Digidesign CoreAudio Setup

Digidesign CoreAudio Setup cannot be accessed under the following circumstances:

- When Pro Tools is running.
- When another CoreAudio-client application is using the Digidesign CoreAudio Driver.

Supported Applications

The Digidesign CoreAudio Driver provides the Supported Applications feature for CoreAudio-compatible applications. This lets you specify which CoreAudio-compatible applications can be used with the Digidesign CoreAudio Driver.

To add support for a CoreAudio-compatible application:

- 1 Launch Digidesign CoreAudio Setup (located in /Applications/Digidesign).
- 2 Click Supported Applications. The Digidesign CoreAudio Supported Applications window opens.

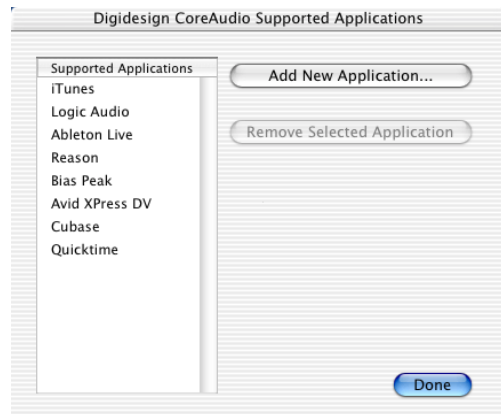

Digidesign CoreAudio Supported Applications window

- 3 In the Digidesign CoreAudio Supported Applications window, click Add New Application. The Open dialog appears.

4 In the Open dialog, navigate to and select the CoreAudio-compatible application you want to add.

5 Click Open. The selected application is added to the Supported Applications list and can be used with the Digidesign CoreAudio Driver.

6 When you are finished adding to the Supported Applications List, click Done.

7 In Digidesign CoreAudio Setup, click Done to apply your changes.

To remove support for a CoreAudio-compatible application:

1 Launch Digidesign CoreAudio Setup (located in /Applications/Digidesign).

2 Click Supported Applications. The Digidesign CoreAudio Supported Applications window opens.

3 In the Supported Applications list, select the application you want to remove.

4 Click Remove Selected Application. The selected application is removed from the Supported Applications list and cannot be used with the Digidesign CoreAudio Driver.

5 When you are finished removing applications from the Supported Applications List, click Done.

6 In Digidesign CoreAudio Setup, click Done to apply your changes.

Buffer Size

When you play a file from a client audio application, the client application divides the file into small packets (buffers) and sends each of these to the Digidesign CoreAudio Driver. The Digidesign CoreAudio Driver copies the client application's input and output buffers to your Digidesign hardware's buffers in a double-buffering scheme. The Buffer Size control in this dialog lets you set the size of each of the two buffers the Digidesign CoreAudio Driver uses on Digidesign hardware. You may select from the following buffer sizes (depending on your Digidesign hardware):

- 128 samples
- 256 samples
- 512 samples
- 1024 samples
- 2048 samples

Small buffers have the advantage of low latency in the record monitor path. (Latency is the time delay between a signal entering the audio inputs and leaving the outputs during recording.)

Larger buffers have the advantage of making the Digidesign CoreAudio Driver more immune to audio dropouts during playback and recording.

In some CoreAudio-client applications, performing various tasks will interrupt the CoreAudio Driver and may result in clicks and pops in audio playback or recording. Choosing medium or large buffers (such as 256, 512, or 1024) can help alleviate this problem.

Changing the Buffer Size for the Digidesign CoreAudio Driver does not affect the H/W Buffer Size settings in the Pro Tools Playback Engine dialog.

To configure Digidesign CoreAudio Hardware Buffer Size:

- 1 Launch Digidesign CoreAudio Setup (located in \Applications\Digidesign).
- 2 From the Buffer Size pop-up menu, select the desired CoreAudio buffer size (in samples). Generally, smaller buffer sizes are preferable. However, if you experience any problems with performance (such as clicks and pops during recording or playback), try increasing the CoreAudio Buffer Size setting.

 *Most audio applications that support CoreAudio will let you adjust the CoreAudio Buffer Size setting from within the application.*

- 3 In Digidesign CoreAudio Setup, click Done to apply your changes.

HW Setup Button

The HW Setup button opens the Hardware Setup dialog for your Digidesign hardware. For more information, refer to the *Getting Started Guide* for your Pro Tools system or the *Pro Tools Reference Guide*.

To configure Digidesign CoreAudio HW Setup:

- 1 Launch Digidesign CoreAudio Setup (located in \Applications\Digidesign).
- 2 Click the HW Setup button to open the Hardware Setup dialog.

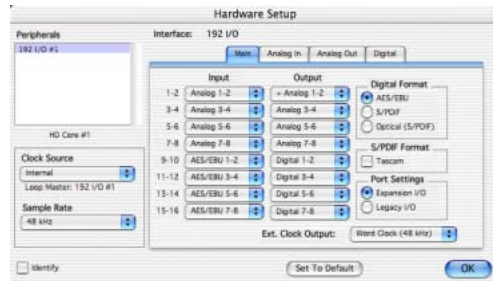



Figure 10. Hardware Setup dialog

- 3 Configure the Hardware Setup dialog for your Digidesign hardware. If you have more than one audio interface connected to your Pro Tools TDM system, be sure to select and configure only the primary audio interface connected to the Pro Tools|HD or Pro Tools|24 MIX Core card.

 *For more information on the Hardware Setup dialog, refer to your Getting Started Guide or the Pro Tools Reference Guide.*

- 4 When you are finished, click OK to close the Hardware Setup dialog.
- 5 In Digidesign CoreAudio Setup, click Done to apply your changes.

Configuring the Apple Sound Preferences or Apple Audio MIDI Setup

To use your Digidesign hardware with common CoreAudio-compatible playback applications (such as Apple iTunes or QuickTime Player), you will need to configure either Sound Preferences or Audio MIDI Setup in addition to Digidesign CoreAudio Setup. However, for most CoreAudio-compatible client applications (such as BIAS Peak or Cubase SX) this is unnecessary because you can configure the CoreAudio Buffer Size setting, and input and output channels from within the application.

Apple Sound Preferences

To configure the Apple Sound Preferences:

- 1 Launch System Preferences (Apple menu > System Preferences).
- 2 Click Sound.
- 3 Click the Output tab and select Digidesign HW as the device for sound output.



Sound Preferences, Output tab

- 4 Click the Input tab and select Digidesign HW as the device for sound input.

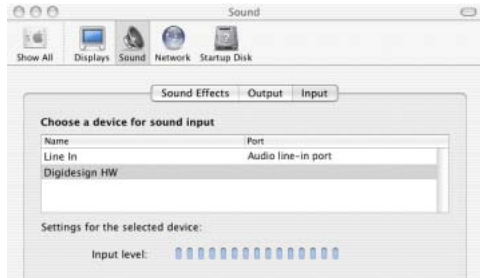

Sound Preferences, Input tab

- 5 Quit System Preferences.

Apple Audio MIDI Setup

To configure the Apple Audio MIDI Setup:

- 1 Launch Audio MIDI Setup (located in Home \Applications \Utilities).
- 2 Select the Audio Devices tab.



Apple Audio MIDI Setup application, Audio tab

- 3 From the System Settings Default Input pop-up menu, select Digidesign HW.
- 4 From the System Settings Default Output pop-up menu, select Digidesign HW.

⚠ Leave System Output and Selected Audio Device set to Built-in Audio. The Digidesign CoreAudio Driver cannot be used for system sounds.

appendix g

Configuring AMS (Mac OS X Only)

Pro Tools recognize the ports on your MIDI interface as generic ports. With Mac OS X, you use Apple's Audio MIDI Setup (AMS) utility to identify external MIDI devices connected to your MIDI interface and configure your MIDI studio for use with Pro Tools.

To configure your MIDI studio in AMS:

1 Launch Audio MIDI Setup (located in Applications\Utilities).

– or –

In Pro Tools, choose Setups > Edit MIDI Studio Setup.

2 Click the MIDI Devices tab. AMS scans your system for connected MIDI interfaces. If your MIDI interface is properly connected, it appears in the window with each of its ports numbered.



Audio MIDI Setup (MIDI Devices tab)

3 For any MIDI devices connected to the MIDI interface, click Add Device. A new external device icon with the default MIDI keyboard image will appear.

4 Drag the new device icon to a convenient location within the window.

5 Connect the MIDI device to the MIDI interface by clicking the arrow for the appropriate output port of the device and dragging a connection or “cable” to the input arrow of the corresponding port of the MIDI interface.

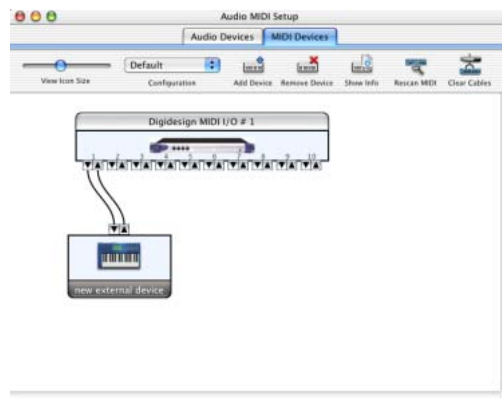

Making MIDI input and output connections

6 Click the arrow for the appropriate input port of the device and drag a cable to the output arrow of the corresponding port of the MIDI interface.

 *To remove a connection, select the cable and press Delete. To delete all connections, click Clear Cables.*

7 Repeat steps 3–6 for each MIDI device in your MIDI setup.

To configure an external MIDI device:

1 Select the external device icon and click Show Info (or double-click the new device icon).



External Device Icon

2 Select a manufacturer and model for the new device from the corresponding pop-up menus. (If the Manufacturer and Model pop-up menus do not provide a name for your particular device, you can type a name.)



Naming a new MIDI device

 *AMS refers to one or more files with the suffix ".middev" in the directory Library\Audio\MIDI Devices for Manufacturer and Model names. Pro Tools installs two such files that contain information for many commercially available MIDI devices, Legacy Devices.middev and Digidesign Devices.middev. If the Manufacturer or Model names for any of your external MIDI devices is not available in the AMS Manufacturer and Model pop-up menus, you can add them by editing any of the current .middev files in any text editor (such as TextEdit).*

3 Click the More Properties arrow to expand the dialog, then enable the appropriate MIDI channels (1–16) for the Transmits and Receives options. (These determine which channels the device will use to send and receive MIDI.)

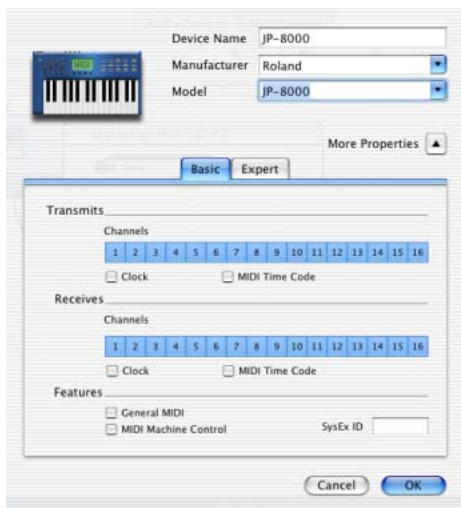

Enabling MIDI channels

4 Click the device image. The window expands to show images for various MIDI devices (such as keyboards, modules, interfaces, and mixers). Select an icon for your device.



Selecting a device icon

 *To use your own custom icons, you can place TIFF image files in `\Library\Audio\MIDI Devices\Generic\Images`, and they will appear as choices in the AMS device window.*

5 Click OK.

The device names you enter appear as MIDI input and output choices in Pro Tools.

index

Numerics

- 1622 I/O 4
- 16-channel peripheral cable adapter 22, 51
- 192 Digital I/O 3
- 192 I/O 2, 35, 63
- 24-bit 3
- 24-bit ADAT Bridge I/O 4
- 882|20 I/O 3
- 888|24 I/O 3
- 96 I/O 3, 36, 64
- 96i 72
 - configuring 37, 65
- 96i I/O 3
- 96-kHz 3

A

- ADAT
 - recording from Pro Tools 91
 - recording to Pro Tools 91
- ADAT Bridge I/O 4
- administrator
 - Macintosh OS X 52
- administrator (XP) 9
- AES/EBU
 - recording from 90
- Apple System software settings 52
- ASIO driver 115
- audio
 - importing 87
 - routing 88, 97
- audio interfaces
 - connecting to Macintosh systems 48
 - connecting to Windows systems 19
 - firmware (Windows) 28, 56
 - HD-series 2
 - heat and ventilation 19
 - Legacy 3

- Audio Regions List 84
- audio tracks 81
- authorization code
 - Macintosh 56
 - Windows 29
- automation 100
 - creating 100
 - editing 100
- Auxiliary Inputs 81, 83, 93, 97

B

- BIOS configuration 10
- Bounce to Disk command 101

C

- Channel Strip controls
 - Mute 96
 - Pan 96
 - Solo 96
 - Volume 96
- click 78
- Click plug-in
 - Accented parameter 78
 - Unaccented parameter 78
- configuring OMS 127
- connecting
 - digital recorders 72
 - effects units 73
 - external SCSI drive 105
 - SMPTE synchronization devices 74
 - studio 69
- connecting audio interfaces
 - Macintosh configuration 48
 - Windows configuration 19
- Control|24
 - Windows 26
- creating a new track 81

D

- DAT recorder
 - connecting to Pro Tools 72
- demo session 25
- DigiNet.inf for ProControl and Control|24 26
- DigiSerial port
 - Windows configuration 15, 42
- digital
 - effects and routing 74
- DigiTest
 - error codes 111
 - Macintosh 54
 - troubleshooting on Windows 28, 55
 - Windows 26
- DMA 13

E

- Edit mode buttons 93
- Edit modes 93
 - Grid 93
 - selecting 93
 - Shuffle 93
 - Slip 93
 - Spot 93
- Edit tools 94
 - Grabber 94
 - Pencil 94
 - Scrubber 94
 - Selector 94
 - Smart Tool 94
 - Trimmer 94
 - Zoomer 94
- Edit window 76
- editing regions 94
- error codes
 - DigiTest 111
- error messages
 - DigiTest on Windows 28, 55
- expansion chassis
 - Windows configuration 15, 41

F

- fade files 75
- firmware
 - audio interfaces (Windows) 28, 56

- formatting hard drives
 - high-level 107
 - low-level 107
- fragmentation 108

G

- Grabber tool 94
- Grid mode 93

H

- hard drives
 - Macintosh requirements 4
 - maintenance 107
 - optimizing 108
 - space requirements 6
 - Windows requirements 4
- hardware installation 13
- HD Accel
 - cards 16, 42
- HD Accel systems 1
- HD Core card
 - Windows configuration 15, 42
- HD Process card
 - Windows configuration 16, 42
- heat 19
- help 8
- HFS 25
- Hibernate 13
- high-level formatting 107, 109
- Hyper-Threading 13

I

- I/O Setup
 - Macintosh configuration 66
 - Windows configuration 38
- importing audio 87
- initializing
 - Macintosh drives 106
 - Windows drives 106
- input levels 88
- installing Pro Tools cards
 - Macintosh configuration 43
 - Windows configuration 17

L

- Legacy audio interfaces
 - Macintosh configuration 51, 65
 - Windows configuration 38

M

- MachineControl 42
 - Windows 15
- Macintosh
 - system requirements
 - hard drives 4
- MacOpener 25, 109
- Master Faders 81, 83, 98
 - creating 99
- memory locations 85, 87
 - defining 85
 - recalling 86
- MIDI 93
 - connections 74
- MIDI click 78
- MIDI control surface 100
- MIDI controls 77, 78
- MIDI Regions List 84
- MIDI tracks 81, 84
- Mix window 76, 96
- mixing 96
- monitoring 93
 - MIDI 93
- Multimedia Setup 26
- Mute button 96

O

- OMS
 - configuration 127
- optimizing hard drives 108

P

- Pan slider 96
- partitioning hard drives 108
- PCI
 - slot guidelines 17
- Pencil tool 94
- playback
 - delay (Macintosh) 59
 - delay (Windows) 32
 - starting and stopping 81

- Playback Engine dialog 79
- playlists 96
- plug-ins 99
- power
 - Windows System Standby 13
- Preferences 23, 52
- Pro Tools
 - automation 100
 - basics 75
 - creating a track 81
 - editing 93
 - Macintosh configuration 57
 - main windows 76
 - plug-ins 99
 - recording audio 89
 - recording MIDI 91
 - remove from Macintosh 53
 - remove from Windows 24
 - sample rate 60
 - saving sessions 79
 - signal routing 97
 - starting a session 75
 - system resources and settings 79
 - tracks 81
 - transport controls 80
 - Windows configuration 29
- Pro Tools software installation
 - Macintosh configuration 52
 - Windows configuration 23
- Pro Tools|HD systems 1
- ProControl
 - Windows 26

Q

- QuickTime 24

R

- recording
 - audio tracks 89
 - from ADAT 91
 - MIDI 92
 - to ADAT tracks 91
- regions 84
 - arranging 95
 - creating 84
 - editing 94
 - trimming 94
- registration 7

- remove Pro Tools
 - Macintosh 53
 - Windows 24
- returns 98
 - creating 98
- rulers 77
- run 27

- S**
- S/PDIF
 - recording from 90
- sample rate
 - and maximum cards 60
- Scrubber tool 94
- SCSI
 - cable length 104
 - requirements 103
 - termination 106
- SCSI BIOS
 - Windows configuration 11
- SCSI drives
 - connecting 105
 - formatting 106
- selections
 - and Bounce to Disk 101
- Selector tool 94
- sends 83, 97
 - assigning 97
- Session Setup window 76
- sessions 75
 - creating 75
 - duplicating 79
 - navigating 85
 - saving 75, 79
 - saving copies of 79
- Shuffle mode 93
- Slip mode 93
- slot order
 - Windows 17
- Smart Tool 94
- Solo button 96
- Spot mode 93
- starting up your system
 - Macintosh configuration 54
 - Windows configuration 26

- studio setup
 - with a mixer 70
 - without a mixer 71
- submixing 97
- SYNC I/O 74
 - DigiSerial (Windows) 15, 42
- system requirements 4
 - Macintosh
 - hard drives 4
 - Windows
 - hard drives 4
- System settings
 - for Windows 13
- system settings
 - Macintosh 52
 - Pro Tools 79
- System Usage window 80

- T**
- TDM FlexCable
 - Windows configuration 16, 43
- technical support 8
- tempo 77
 - setting 77
- tempo events 77
- termination of SCSI drives 106
- track height
 - changing 86
- tracks
 - audio 81
 - Auxiliary Inputs 81, 83, 97
 - creating 81
 - Master Faders 81, 83, 98
 - MIDI 81, 84
 - playing back 89
 - playing back MIDI 92
 - recording 89
 - recording MIDI 92
 - types 81
- Transport window 76, 80
- Trimmer tool 94
- trimming regions 94

U

- uninstall
 - Macintosh 53
 - Windows 24
- USD 42

V

- validating Pro Tools software
 - Macintosh configuration 56
 - Windows configuration 29
- Volume fader 96

W

- Windows
 - BIOS configuration 10
 - configuring MIDI 26
 - required System settings 13
 - SCSI BIOS configuration 11
 - system requirements
 - hard drives 4
 - System Standby 13
- windows 76
 - Edit window 76
 - Mix window 76, 96
 - Session Setup window 76
 - Transport window 76, 80
- Windows System Standby 13
- www.digidesign.com 8

Z

- Zoom presets
 - recalling 86
 - storing 87
- Zoomer tool 94