



A Division of Sony Corporation of America

PROFESSIONAL

RECORDING

EQUIPMENT

JH-110 SCHEMATIC CHANGES

1. Schematic SC25E600, Phase Locked Loop Board, page 3-19
IC9 no longer in circuit, jumper from pin 5 to pin 8
change C7 from .0033 μ f to .0027 μ f
change R32 from 240 ohms to 120 ohms
change IC16 from 7402 to 74C02
change IC19 from 7427 to 74LS27
2. Schematic SC26D001, Analog Torque Board, page 3-21
For 110-14 Hi/Lo (-25) Table of Optional/Variable components
change R92 from 8.2k to 3.6k ohms
3. For Option 7 only:
Schematic SC27D055, Bias and Erase Board, page 5-13
change R74 to 12k ohms
change C35 to 2200pf
change L1 to 910 μ H
add a 470pf cap from plug 7, pin 9 (Bias Hi) to ground
4. Schematic SC2700C0059, Monitor Amp Board, page 5-25
change C13 & C16 from 15MF35V-CTA10 to 22MF25V-CLY
5. Schematic SC26D033 (page 6-3) and SC26D027 (page 6-5)
Power Supply & Motor Driver Board
change R24 & R25 from 470k to 330k on both schematics
6. Schematic SC26B1008, Electronic Flutter Damper Board, page 3-25
change C103 from .047/250 to .1/250.
7. Schematic SC25B287, Capstan Tachometer Board, page 3-35
change R2 from 3.3 megohm to 1.3 megohm.
add a 1.3 megohm from Pin 1, IC1 to ground.

JH-110 SERIES PROFESSIONAL TAPE RECORDERS

THIRD PRINTING — APRIL, 1982

INTRODUCTION	1
OPERATING PROCEDURES	2
TAPE TRANSPORT	3
RTZ III AUTO LOCATOR	4
AUDIO ELECTRONICS	5
POWER SUPPLY	6
MAINTENANCE	7
TROUBLESHOOTING	8
SPARE PARTS KITS	9
UPGRADE KITS	10
APPENDICES	

The JH-110 Series includes the following systems:

- the JH-110B System — 10½" reel — 1, 2 and 4 track — ¼" and ½" tape
- the JH-110B-14 System — 14" reel — 1, 2 and 4 track — ¼" and ½" tape
- the JH-110C-8 System — 10½" reel — 8 track — 1" tape
- the JH-110BC System — 30cm reel · DIN stereo broadcast recorder
- the JH-110BX System — 10½" reel — 1 or 2 track broadcast recorder
- the JH-110M System — 14" reel — disc mastering reproducer



1400 W. Commercial Blvd. • Fort Lauderdale, Florida 33334 • Phone (305) 491-0825

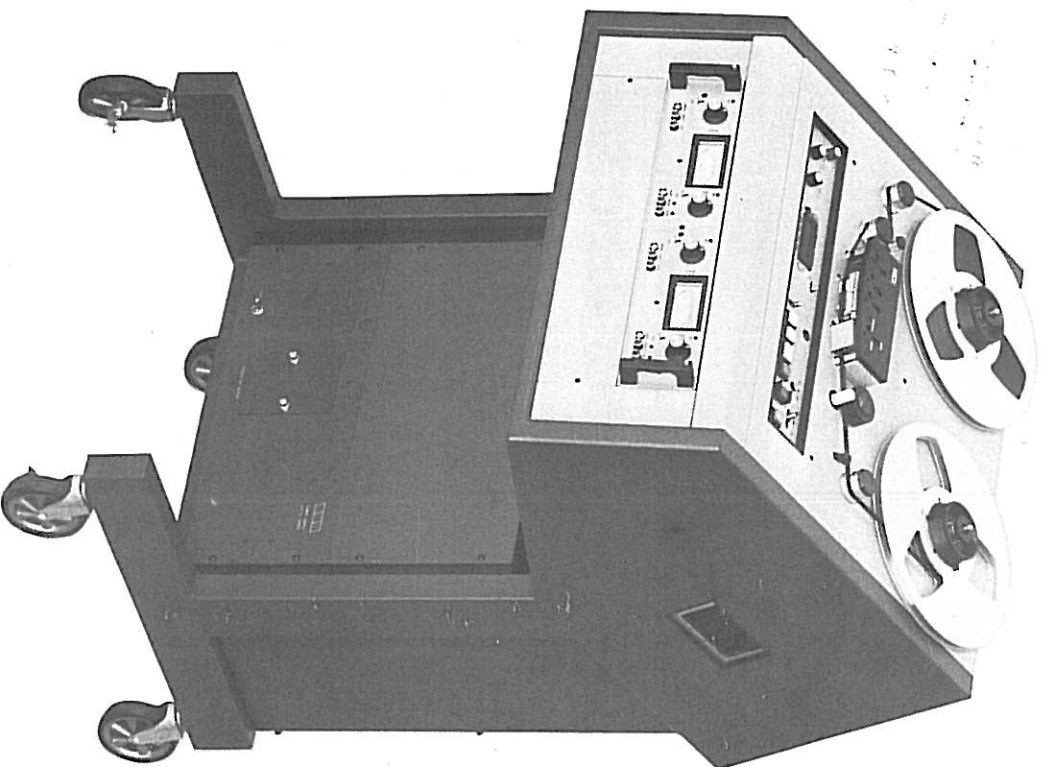

JH-110B

TABLE OF CONTENTS

SECTION 1 — INTRODUCTION

1.1	General Information	1-1
1.2	Transports.....	1-3
1.2.1	JH-110B.....	1-4
1.2.2	JH-110B-14	1-4
1.2.3	JH-110C-8	1-6
1.2.4	JH-110BC.....	1-9
1.2.5	JH-110BX.....	1-9
1.2.6	JH-110M.....	1-12
1.3	Audio Electronics.....	1-15
1.3.1	Standard Audio Electronics	1-15
1.3.2	Broadcast Audio Electronics (JH-110BC)	1-16
1.3.3	Broadcast Audio Electronics (JH-110BX).....	1-16
1.3.4	Mastering Audio Electronics	1-17
1.4	RTZ III and Autolocator III	1-18
1.4.1	RTZ III.....	1-18
1.4.2	RTZ IIIM.....	1-19
1.4.3	Autolocator III	1-19
1.5	Power Supply	1-19
1.6	Options	1-21
1.7	Accessories	1-21

SECTION 2 — OPERATING PROCEDURES

2.1	Controls and Indicators	2-1
2.2	Operating Procedures	2-8
2.2.1	Transport Motion Controls	2-8
2.2.2	Reference and Speed Controls	2-10
2.2.3	RTZ III Autolocator Controls	2-11
2.2.4	Audio Controls	2-12

SECTION 3 — TAPE TRANSPORT

3.1	General Description	3-1
3.2	Control Logic	3-1
3.3	Capstan Servo System	3-8
3.3.1	Phase Locked Loop	3-8

TABLE OF CONTENTS (continued)

3.3.2	Reference Frequency	3-10
3.4	Tape Tension Servo System	3-12
3.4.1	Idle Servo Loops	3-14
3.4.2	Play Servo Loops	3-14
3.4.3	Fast Servo Loop	3-14
	Tape Transport Schematics	3-17
	SC25D027 Control Logic Board	3-17
	SC25E600 Phase Locked Loop Board	3-19
	SC26D001 Analog Torque Board	3-21
	SC25D416 Interface/Lamp Driver Board	3-23
	SC26B1008 Electronic Flutter Damper Board	3-25
	SC25B042 Solenoid Driver Board	3-27
	SC25B160 Photo Sensor Board	3-29
	SC25E085 Transport Mother Board	3-31
	WD26E666 Interconnect Harness	3-33
	SC25B287 Capstan Tach Board	3-35
	SC26C150 Remote Cable	3-37
	WD27D940 Remote Control Cable, JH-110C	3-39
	SC26C003 Head Connector	3-41
	SC28F044 Interconnect Harness, JH-110M	3-43
	SC26B1003 Remote MVC	3-45
	TW27D-43 Head Assembly	3-47
	TW27D-47 Pinch Roller Assembly	3-49
	TW27D-45 Tape Lifter Assembly	3-51
	TW27D-81 Electronic Dancer Arm Assembly	3-53
	TW27D-44 Dancer Arm Assembly (Air Dashpot)	3-55
	TW27D-49 Reel Motor Brake Assembly	3-57
	TW27D-46 Head Shield Assembly	3-59
	TW27D-48 Capstan Motor and Tach Assembly	3-61
	TW27C-34 Rear Connector Pin Outs	3-63
	TW27C-35 Control Panel Replacement Parts	3-65

SECTION 4 — RTZ III AND AUTOLOCATOR III

4.1	General Description	4-1
4.1.1	RTZ III	4-1
4.1.2	Autolocator III	4-2
4.2	Hardware Functional Description	4-3
4.3	Program Description	4-6
4.4	RTZ III M Lathe Control Outputs	4-6
4.4.1	Scully Lathe	4-6
4.4.2	Neumann Lathe	4-6
4.4.3	Interfacing Information	4-6
	RTZ III Schematics	
	SC25E611 Processor Board	4-9
	SC25C609 Display Board	4-11
	SC25C610 Display Board, A/L III	4-13
	SC25C625 Processor Plug On Board	4-15
	SC25B617 Data and Matrix Interconnect	4-17
	WD27D939 Remote Cable, A/L III	4-19
	SC26D191 JH-47 Remote Readout	4-21

TABLE OF CONTENTS (continued)

WD26B193 JH-47 Remote Readout Cable	4-23
TW90E-14 A/L III Assembly	4-25

SECTION 5 — AUDIO ELECTRONICS

5.1 General Description	5-1
5.2 Record Mode	5-2
5.3 Reproduce Mode	5-5
5.4 Broadcast Audio Electronics	5-5
5.5 Mastering Audio Electronics	5-6
5.6 Eight Track Remote	5-6
Audio Electronics Schematics	5-9
SC27D914 Record Board	5-9
SC27D913 Reproduce Board	5-11
SC27D055 Bias and Erase Board	5-13
SC27D916 I/O Amp Board	5-15
SC27E917 Audio Mother Board	5-17
SC27E080 Broadcast Amp Board	5-19
SC27E915 Front Panel EQ Board	5-21
SC27D005 Strip Board	5-23
SC27C059 Monitor Amp Board	5-25
SC27C937 Remote Master Switching Board	5-27
SC27D938 Remote Channel Status Board	5-29
WD27B932 Channel Status Cable	5-31
WDA27B931 Audio Drawer Remote Harness	5-33
TW27E080 Remote Control Assembly	5-35

SECTION 6 — POWER SUPPLY

6.1 General Description	6-1
6.2 Motor Driver Board	6-1
6.3 Voltage Measurements	6-2
6.4 Power Supply Schematic	6-3
SC26D033 Power Supply & Motor Driver Board	6-3
SC26D027 Power Supply & Motor Driver Board	6-5

SECTION 7 — MAINTENANCE

7.1 Equipment Needed	7-1
7.2 Tape Path Adjustments	7-2
7.2.1 Turntable Height	7-2
7.2.2 Head Height	7-3
7.2.3 Head Zenith	7-3
7.3 Capstan Pinch Roller Adjustment	7-4
7.4 Tape Lifter Adjustments	7-5
7.5 Dancer Arm Adjustments	7-5
7.5.1 Air Dashpot Dancer Arm	7-5
7.5.2 Electronic Dancer Arm	7-7
7.6 Reel Motor Brakes	7-7

TABLE OF CONTENTS (continued)

7.7	Tape Tension	7-8
7.8	Capstan Speed	7-10
7.9	Manual Velocity Control Test & Adjustments	7-11
7.10	Tape Load Photo Sensor Adjustments	7-11
7.11	Equalization and Overbiasing	7-11
7.12	Audio Electronics Alignment	7-12
7.12.1	Channel VU Meter Calibration	7-12
7.12.2	Reproduce Input Balance	7-12
7.12.3	Head Wrap Adjustments	7-12
7.12.4	Reproduce Level Adjustments	7-13
7.12.5	Azimuth Adjustments	7-14
7.12.6	Repro Equalization Adjustments	7-14
7.12.7	Erase Adjustments	7-15
7.12.8	Bias Adjustments	7-16
7.12.9	Over-Bias Level	7-17
7.12.10	Record Adjustments	7-17
7.12.11	Record Equalization Adjustments	7-18
7.12.12	Reproduce Low Frequency EQ Adjustments	7-18
7.12.13	Record Linearity Adjustments	7-19
7.12.14	Noise Tests	7-20
7.13	Quick Alignment Check	7-20
7.14	Scrape Flutter Filter	7-24

SECTION 8 — TROUBLESHOOTING

8.1	Introduction	8-1
8.2	Control Logic Board	8-1
8.3	Analog Torque Board	8-6
8.4	Power Supply Motor Driver Board	8-7
8.5	Phase Locked Loop Board	8-8
8.6	Audio Electronics	8-10
8.7	RTZ III	8-12

SECTION 9 — SPARE PARTS KITS

SECTION 10 — UPGRADING KITS

10.1	Possible Configurations	10-1
10.2	Upgrading A Mono Machine To A Stereo Machine	10-1
10.3	Upgrading A Two Track Machine To A Four Track Machine	10-2
10.4	Installing An Additional Play Head	10-3

APPENDICIES

WARRANTY

LIST OF ILLUSTRATIONS

FIGURE NUMBER	TITLE	
1-1	V.P. Cabinet Dimensions	1-2
1-2	H.P. Cabinet Dimensions	1-2
1-3	JH-110B Transport Deck	1-3
1-4	JH-110BC Transport	1-9
1-5	JH-110M Transport	1-12
1-6	Audio Panel	1-15
1-7	Broadcast Audio Panel	1-17
1-8	Mastering Audio Panel	1-17
1-9	RTZ III Panel	1-18
1-10	RTZ IIIM Panel	1-18
2-1	Transport Control Panel	1-22
2-2	JH-110M Fast Motion Limit Control	2-1
2-3	JH-110B-14 Torque Limit Switches	2-2
2-4	Reference and Speed Controls	2-2
2-5	RTZ III Controls	2-3
2-6	RTZ IIIM Controls	2-3
2-7	Audio Controls and Indicators	2-4
2-8	Broadcast Audio Controls and Indicators	2-5
2-9	Mastering Audio Controls and Indicators	2-6
2-10	Transport Motion Controls	2-9
2-11	RTZ III Display	2-12
2-12	Audio Controls	2-13
3-1	Transport Simplified Block Diagram	2-16
3-2	Tape Load and Stop Commands	3-3
3-3	Play and Record Commands	3-4
3-4	Fast Forward Command	3-5
3-5	Rewind Command	3-6
3-6	Edit and Edit Commands	3-7
3-7	MVC and Tape Lifter Commands	3-8
3-8	Capstan Servo Block Diagram	3-9
3-9	Internal Reference Circuit, Fixed	3-10
3-10	Internal Reference Circuit, Variable	3-11
3-11	External Reference Circuit, with Signal	3-11
3-12	External Reference Circuit, without Signal	3-12
3-13	Tape Tension System Block Diagram	3-13

LIST OF ILLUSTRATIONS (continued)

4-1A	RTZ III Block Diagram	4-4
4-1B	AutoLocator III Block Diagram	4-5
4-2	Background Loop Flowchart	4-7
4-3	Mastering Interface	4-8
5-1	Record Mode Block Diagram	5-3
5-2	QUIOR Timing Diagram	5-4
5-3	Repro Mode Block Diagram	5-7
5-4	Monitor Amp Block Diagram	5-8
7-1	Tape Path	7-2
7-2	Head Adjustments	7-3, 7-13
7-3	Tape Lifter Assembly	7-4
7-4	Dancer Arm Assembly	7-6
7-5	Brake Adjustments	7-7
7-6	Repro Card Adjustments	7-13, 7-19, 7-21
7-7	Erase and Bias Adjustments	7-15
7-8	Bias Card Adjustments	7-17, 7-22
7-9	Record Card Adjustments	7-18, 7-23
7-10	Intermodulation Distortion Curves	7-19
7-11	Weighting Network	7-20
7-12	Scrape Filter Removal	7-24
7-13	Scrape Filter Disassembly	7-25

LIST OF TABLES

TABLE NUMBER	TITLE	
1-1	Specifications, JH-110B and JH-110B-14 Transports	1-5
1-2	Specifications, JH-110C-8 Transport	1-7
1-3	Specifications, JH-110BC Transport	1-10
1-4	Specifications, JH-110M Transport	1-13
1-5	Specifications, Standard Audio Electronics	1-16
1-6	Specifications, Broadcast Audio Electronics	1-16
1-7	Specifications, Mastering Audio Electronics	1-18
1-8	Specifications, RTZ III and A/L III	1-19
1-9	Input Power Specifications	1-19
1-10	Ordering Numbers	1-20
6-1	Power Supply Outputs	6-1

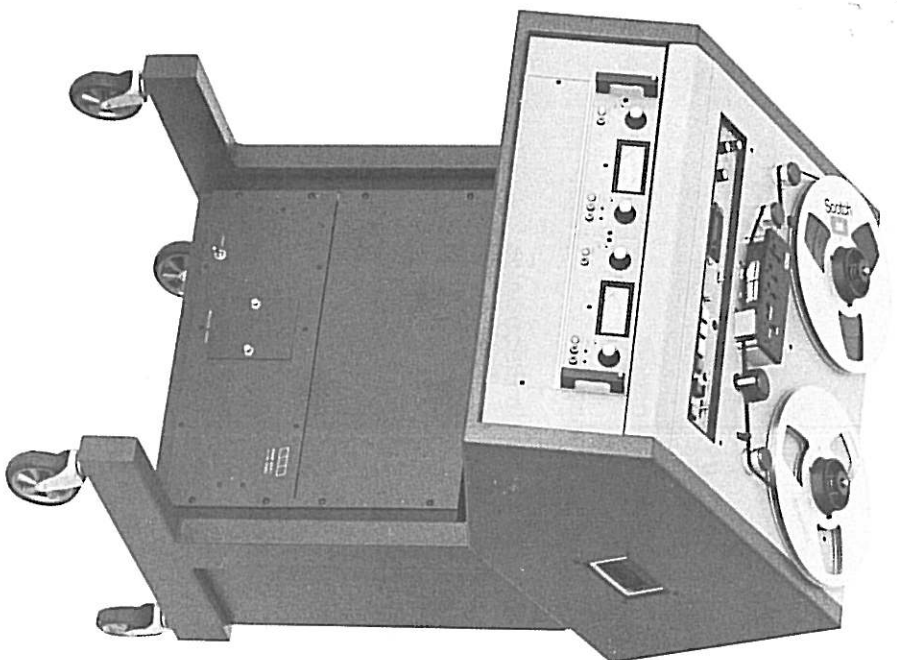

JH-110BX

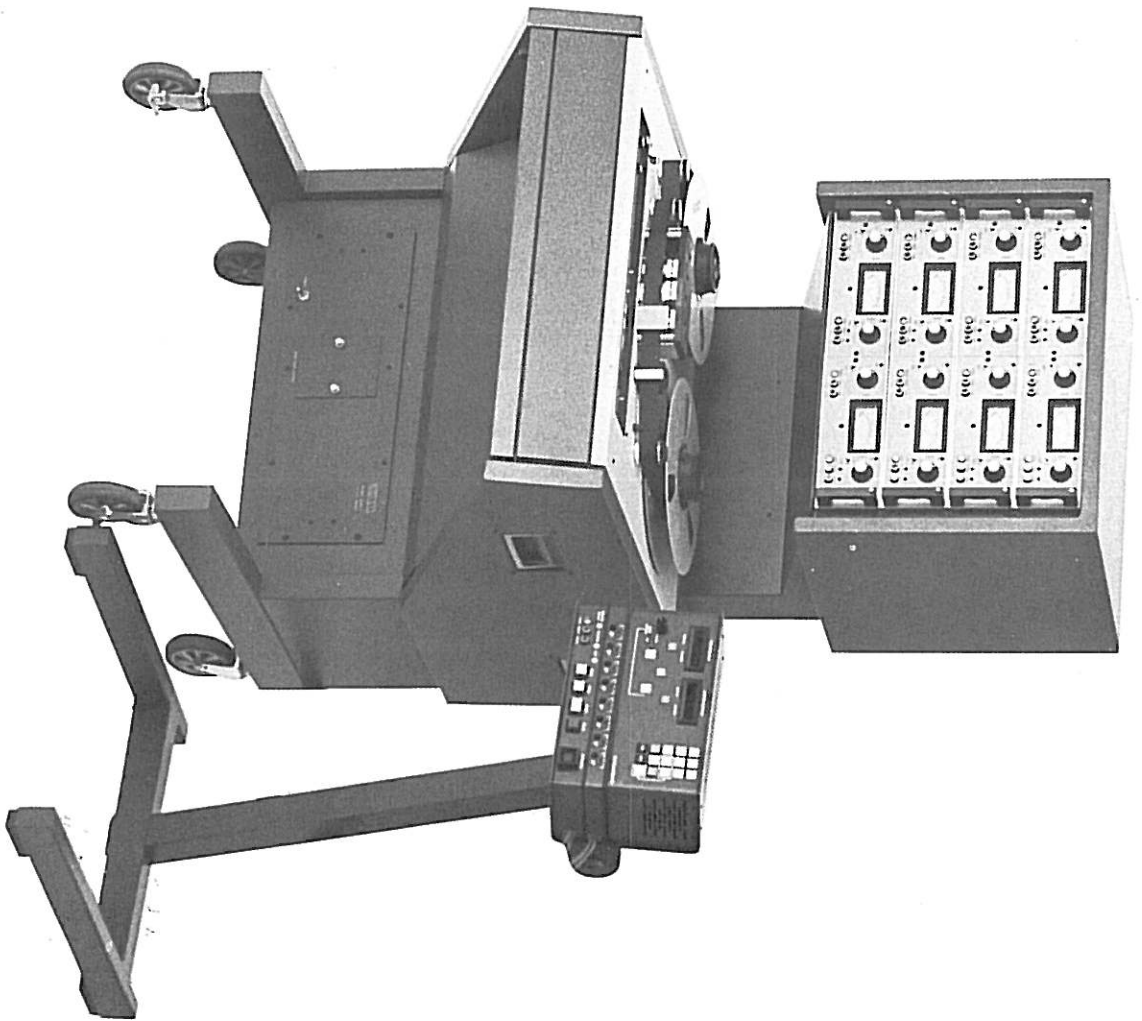

JH-110C-8

SECTION I

INTRODUCTION

1

1.1 General Information

The JH-110 series of professional tape recorders consists of a wide range of models designed for a variety of applications. Models are available for use with 1/4 inch, 1/2 inch, and one inch magnetic tape, for mono, stereo, 4-track, and 8-track recordings. All models accommodate 10-1/2 inch or smaller metal or plastic reels; some models accommodate up to 14 inch reels. DIN hub adapters can be used with any model.

JH-110B tape recorders are available in two tape speed ranges. High speed transports operate at 7-1/2, 15, and 30 inches per second (19, 38, and 76 cm/s); low speed transports operate at 3-3/4, 7-1/2, and 15 inches per second (9-1/2, 19, and 38 cm/s). Changing the speed of the transport automatically selects the proper audio equalization for that speed. Tape speed can also be controlled by an

external source or by a variable internal source for operation at non-standard speeds.

There are two cabinet styles for the JH-110B, the variable profile cabinet and the high profile cabinet. The variable profile cabinet houses from one to four channels of record/playback electronics, the transport, and its power supply. The high profile cabinet houses from one to eight channels of record/playback electronics, the transport, and its power supply.

Both cabinets are mounted on casters for mobility. The record/playback audio electronics are mounted in drawers and the transport base is hinged, making all components easily accessible. All models can also be ordered unmounted for installation in standard 19 inch equipment cabinets. Cabinet dimensions and weights are given in figures 1-1 and 1-2.

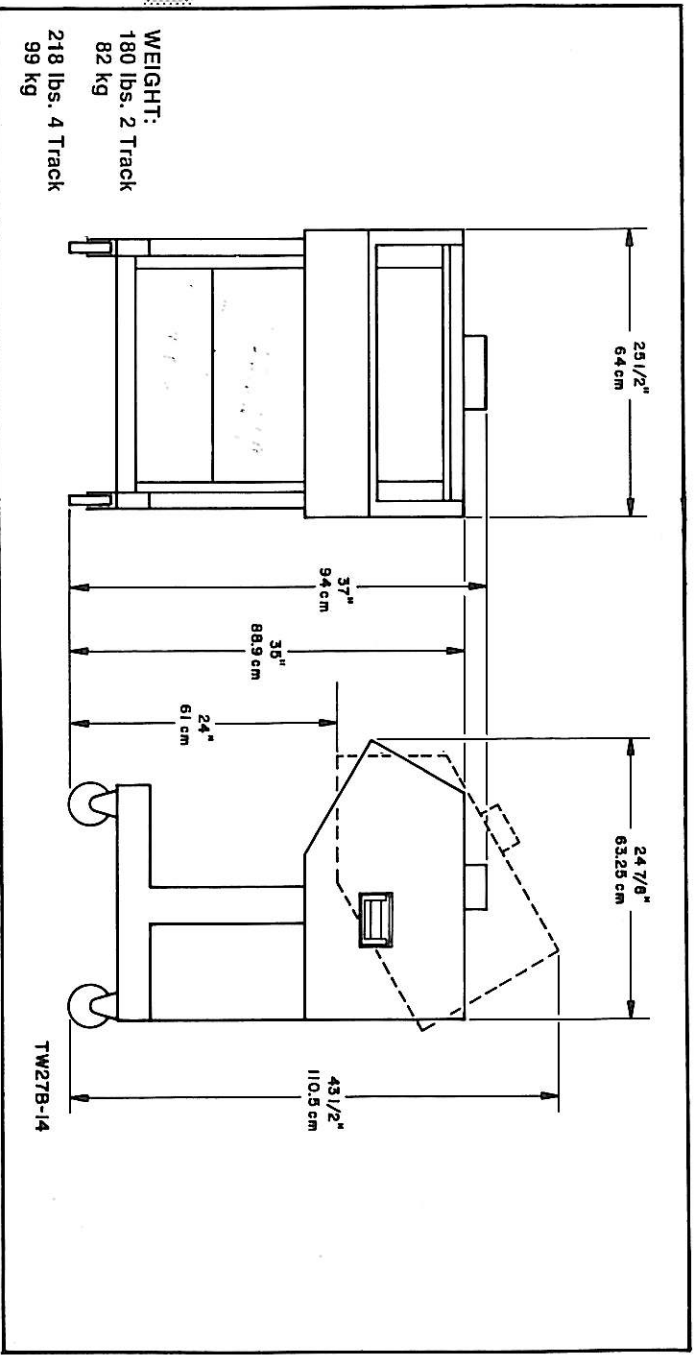

Figure 1-1 Variable Profile Cabinet Dimensions

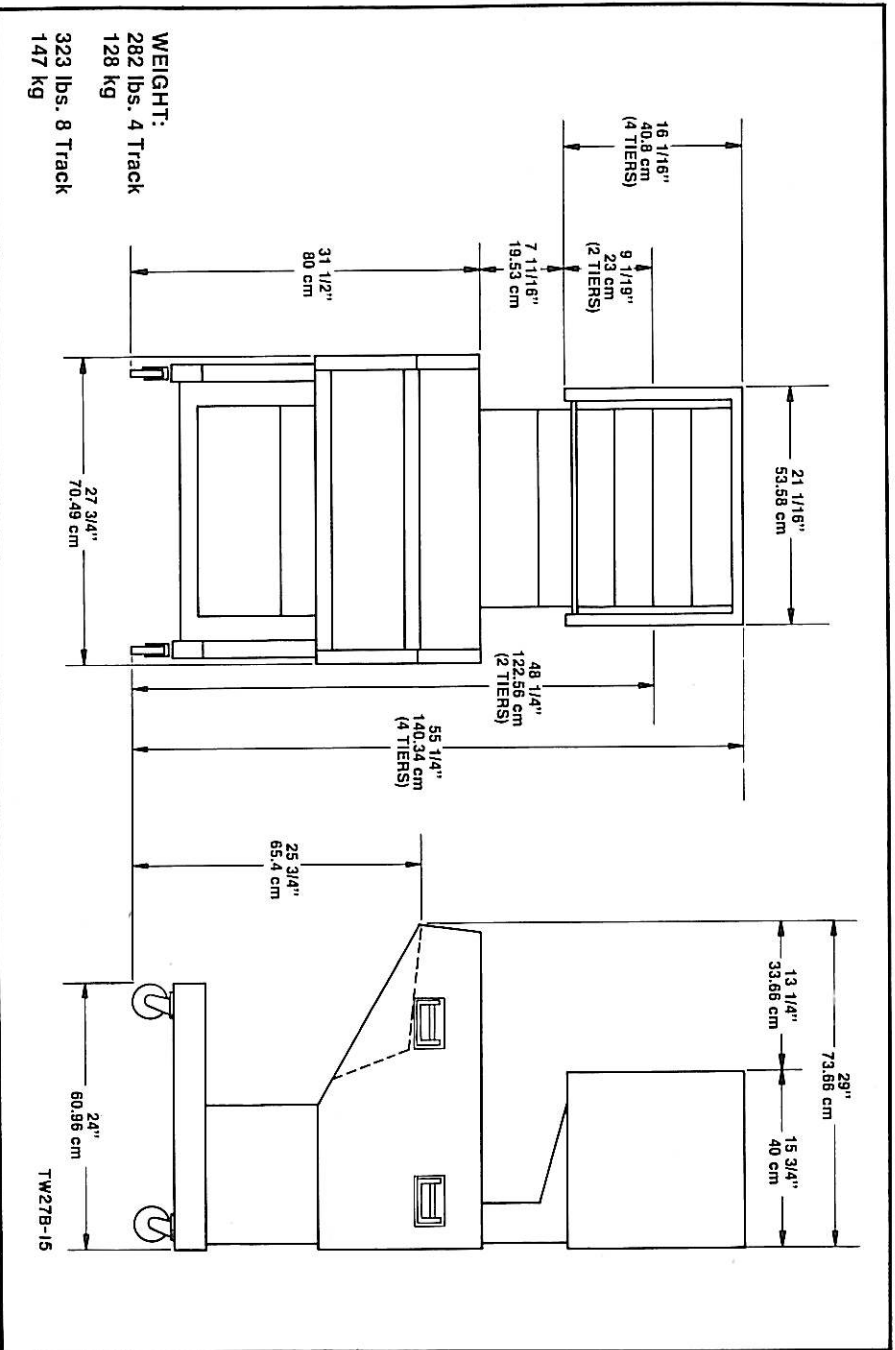

Figure 1-2 High Profile Cabinet Dimensions

1.2 Transports

There are basically six models of the JH-110B tape transport:

the standard JH-110B 10½ inch reel transport
the JH-110B-14 fourteen inch reel transport

the JH-110C-8 eight track transport
the JH-110BC DIN broadcast transport
the JH-110BX broadcast transport
the JH-110M disc mastering transport

There are a variety of options for each model to fit the user's specific needs.

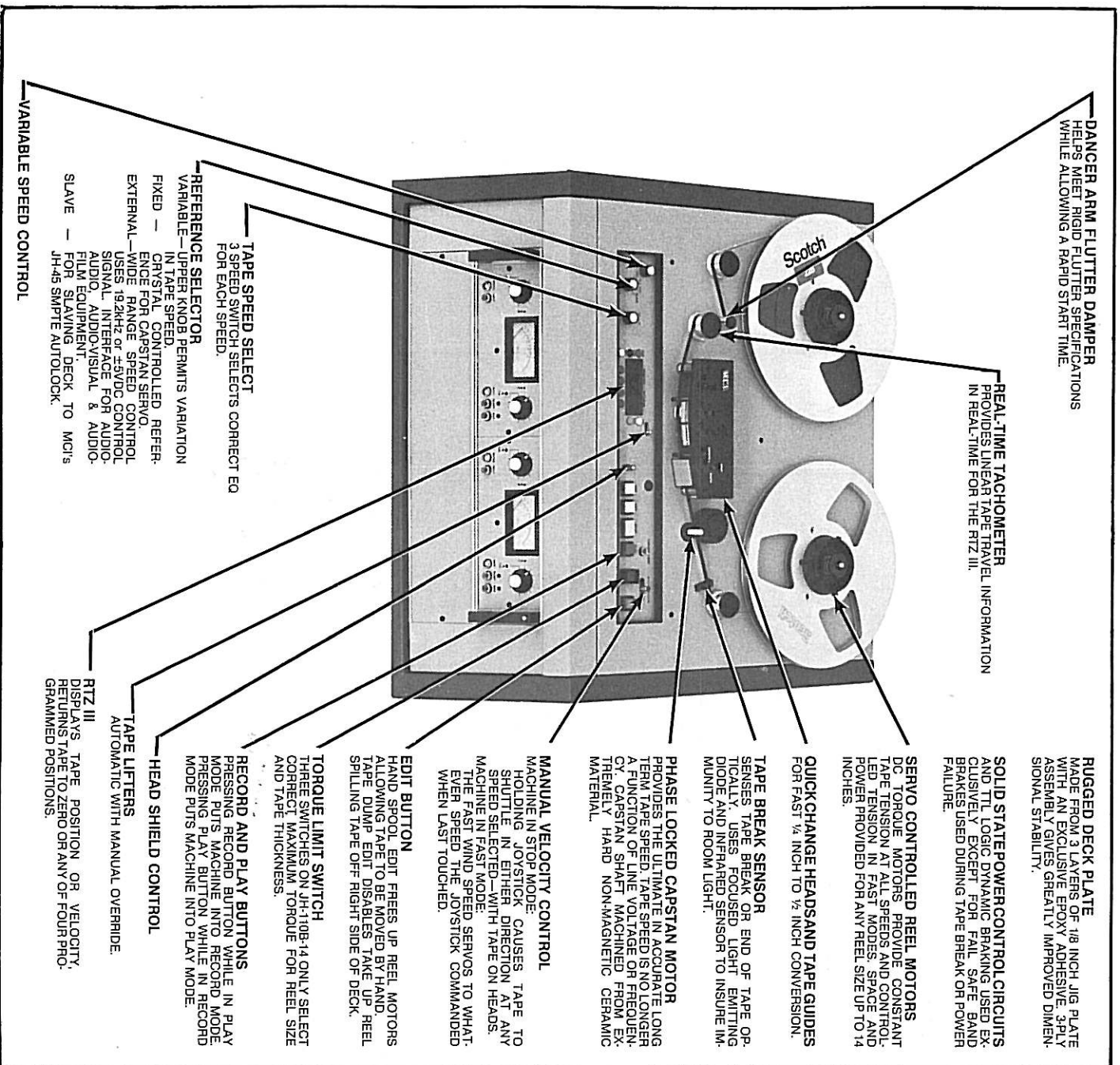

Figure 1-3 JH-110B Transport Deck

1.2.1 JH-110B

The JH-110B, shown in Figure 1-3, is the standard model three speed playback and record tape transport. Full width 1/4 inch, two track 1/4 inch, and four track 1/2 inch tape versions are available. All versions can use 3 inch to 10-1/2 inch metal or plastic reels. A torque limit switch lowers the starting torque of the reel motors for small reels or for delicate tapes.

Available as standard equipment on all the JH-110B decks is the RITZ III autolocator. The autolocator returns the tape to the zero position, or positions the tape at any of four programmable positions. A LED display displays the tape position in minutes and seconds of actual playback time, or the tape speed in inches per second.

During playback and record modes, a ceramic capstan and pinch roller arrangement controls the tape speed. A phase locked loop servo system drives the dc capstan motor. The servo locks the capstan speed to a crystal oscillator reference. A reference switch can alternatively select a voltage controlled oscillator (VCO) or an external signal as the reference for the phase locked loop. The VCO allows variable capstan speed control for operating at any speed 20% above or below the standard speeds. The transport will accept either a clock frequency (19.2 KHz) or a variable dc level (-5 to +5 volts) as an external reference input.

Two servo controlled dc motors regulate the tape tension, keeping it constant during all modes of operation. An infrared tape load sensor brakes the supply and take up reel motors at the end of roll, when the tape breaks, or when the tape is removed from the sensor slot. An Edit switch can

disable the tape tension servo allowing the reels to be moved by hand without resistance from the motors. The manual velocity control (MVC) joystick gives complete control of the tape's motion and speed from either the stop mode or the forward/rewind modes.

To facilitate head alignment and maintenance, the heads are mounted on a precision machined head bridge assembly. Loosening two hex screws separates the head bridge from the transport deck. Removing the head bridge does not affect the head alignment. Swapping head assemblies and roller guides quickly converts 1/2 inch tape machines to 1/4 inch tape.

Standard head bridges contain three heads: reproduce, record/cue and erase. Additional mounting space is provided for a preview head which may be ordered as an option. Tape lifters move the tape away from the heads during the fast forward and rewind modes to reduce head wear.

The JH-110B mounts in the variable profile cabinet; its dimensions are indicated in Figure 1-1. Specifications for the JH-110B are listed in Table 1-1.

1.2.2 JH-110B-14

The JH-110B-14 contains all the features of the JH-110B plus the capability of mounting 14 inch reels. Three torque selection switches adjust the reel motor torque for different size and weight reels. The JH-110B-14 also mounts in the variable profile cabinet.

Specifications for the JH-110B-14 are listed in Table 1-1.

TABLE 1-1 SPECIFICATIONS
JH-110B and JH-110B-14

Reel Size	JH-110B JH-110B-14	3 to 10½ inches 3 to 14 inches	NAB or EIA, plastic or metal reels, DIN hubs optional
Tape Width		¼ inch full width ¼ inch 2 track ½ inch 4 track ½ inch 2 track	NAB or DIN track separation
Tape Speeds			
High Speed (Standard)		7½, 15, & 30 ips (19, 38 & 76 cm/s)	Phase locked loop dc capstan controlled referenced to fixed crystal oscillator or variable VCO output
Variable		6 to 36 ips (15 to 91 cm/s)	
Low Speed (Option)			
Fixed		3¾, 7½ & 15 ips (9½, 19 & 38 cm/s)	
Variable		3 to 18 ips (8 to 46 cm/s)	
Long Term Speed Stability		better than 0.02%	
Tape Tension			
¼ inch		5½ ±¼ oz.	Measured between capstan and roller guide
½ inch		5¾ ± ¼ oz. at all speeds beginning to end of reel	
Start Time		900 msec @ 30 ips 500 msec @ 15 ips 500 msec @ 7½ ips	To 0.1% DIN 45507 flutter with 10½ inch reels
Rewind Time		110 sec for 2500 ft. 170 sec for 4800 ft.	
Wow and Flutter		30 ips < 0.020% 15 ips < 0.030% 7½ ips < 0.045%	DIN 45507 weighted DIN 45507 weighted DIN 45507 weighted

TABLE 1-1 SPECIFICATIONS
(continued)

Frequency Range					
Record/Reproduce (Using Ampex 456 tape)	30 ips, AES	40Hz to 28 KHz	+0.75, -2dB		
	15 ips, NAB	30Hz to 24 KHz	+0.75, -2dB		
	7½ ips, NAB	30Hz to 20 KHz	+0.75, -1.5dB		
Signal to Noise*		mono	2 track	4 track	
	Record/Reproduce referenced to 510nWb/m	30 ips, AES	70	66	66
		15 ips, NAB	68	64	64
7½ ips, NAB		67	63	63	
Weighted dB(A)	30 ips, AES	74	71	70	
	15 ips, NAB	70	68	68	
	7½ ips, NAB	70	67	67	
Harmonic Distortion*					
	1KHz fundamental at 510 nWb/m	30 ips, AES	<0.35%		
		15 ips, NAB	<0.52%		
7½ ips, NAB		<1.6%			
3rd harmonic	30 ips, AES	<0.10%			
	15 ips, NAB	<0.10%			
	7½ ips, NAB	<0.10%			
2nd harmonic	30 ips, AES				
	15 ips, NAB				
	7½ ips, NAB				
3rd harmonic 3% fluxivity level	30 ips, AES	1040nWb/m			
	15 ips, NAB	1020nWb/m			
	7½ ips, NAB	1000nWb/m			
Depth of Erasure referenced to 250nWb/m		better than 80 dB at 1 KHz			
Bias and Erase Frequency	120 KHz				

* Typical values given. Specifications are largely dependent on tape formulation. Also, the performance of any particular type of tape varies from batch to batch.

1.2.3 JH-110C-8

The JH-110C-8 is the eight track version of the JH-110B. This transport uses one inch wide recording tape mounted on 10-1/2 inch or smaller reels. Monitor input and record ready status for each channel can be selected from the remote control unit or from the audio front panel switches. The remote control unit also contains mo-

tion control switches which duplicate the functions of the switches on the transport.

The JH-110C-8 uses the AutoLocator III mounted directly above the remote unit rather than the deck-mounted RTZ III. The AutoLocator III provides additional memories, a repeat function, and variable tape speed control.

The JH-110C-8 mounts in the high profile cabinet; its dimensions are indicated in Figure 1-2. Specifications for the JH-110C-8 are listed in Table 1-2. The AutoLocator III and the remote con-

trol unit mount on the JH-20 accessory stand and connect to the transport via a 35-foot cable harness.

TABLE 1-2 SPECIFICATIONS
JH-110C-8

Reel Size	10½ inch max	
Tape Width	1 inch 8-track	Optional ½ inch 4-track
Tape Speeds		
Fixed	7½, 15, & 30 ips (19, 38 & 76 cm/s)	Phase locked loop dc capstan control referenced to fixed crystal oscillator
Variable	6 to 36 ips (15 to 91 cm/s)	or variable VCO
Long Term Speed Stability	better than 0.02%	
Tape Tension	6 ± ¼ oz. at all tape speeds beginning to end of reel	Measured between capstan and roller guide
Start Time	900 msec @ 30 ips 500 msec @ 15 ips 500 msec @ 7½ ips	To 0.1% DIN 45507 flutter with 10½ inch reels
Rewind Time	110 sec for 2500 ft.	
Wow and Flutter	30 ips < 0.015% 15 ips < 0.020% 7½ ips < 0.030%	DIN 45507 weighted DIN 45507 weighted DIN 45507 weighted
Frequency Range	Record/Reproduce (Using Ampex 456 tape)	
	30 ips, AES 15 ips, NAB 7½ ips, NAB	40Hz to 28 KHz +0.75, -2dB 30Hz to 24 KHz +0.75, -2dB 30Hz to 20 KHz +0.75, -1.5dB
Signal to Noise *		4/8 Track
Record/Reproduce referenced to 510nWb/m	30 ips, AES 15 ips, NAB 7½ ips, NAB	66 64 63
Weighted dB(A)	30 ips, AES 15 ips, NAB 7½ ips, NAB	70 68 67

TABLE 1-2 SPECIFICATIONS
(continued)

Harmonic Distortion *		
1kHz fundamental at 510 nWb/m		
3rd harmonic	30 ips, AES 15 ips, NAB 7½ ips, NAB	<0.35% <0.52% <1.6%
2nd harmonic	30 ips, AES 15 ips, NAB 7½ ips, NAB	<0.10% <0.10% <0.10%
3rd harmonic 3% fluxivity level	30 ips, AES 15 ips, NAB 7½ ips, NAB	1040nWb/m 1020nWb/m 1000nWb/m
Depth of Erasure referenced to 250nWb/m		better than 80 dB at 1 kHz
Bias and Erase Frequency	120 KHz	

* Typical values given. Specifications are largely dependent on tape formulation. Also, the performance of any particular type of tape varies from batch to batch.

1.2.4 JH-110BC

The JH-110BC is a two speed playback and record broadcast tape deck. It can be operated in either DIN stereo or mono modes. The broadcast deck uses 1/4 inch recording tape and will accommodate any size reel or platter up to 30 cm in diameter. Built-in tape scissors and a tape marker are included for editing.

This transport is equipped with the broadcast version audio electronic drawers which include a monitor amplifier and speaker. Standard equipment also includes the RTZ III autolocator.

Specifications for the JH-110BC are listed in Table 1-3.

1.2.5 JH-110BX

The JH-110BX is a two-speed (7½, 15 ips) playback and record tape deck designed for broadcast applications. It uses 1/4-inch recording tape on reels up to 10½ inches in diameter. Both monaural and two-track versions are available. The RTZ III is standard equipment on the JH-110BX.

This transport comes equipped with audio electronics similar to the standard JH-110B electronics. The JH-110BX does not include cue(sync) reproduce mode or instant NAB/IEC standard switching.

Specifications for the JH-110BX are comparable to the JH-110B.

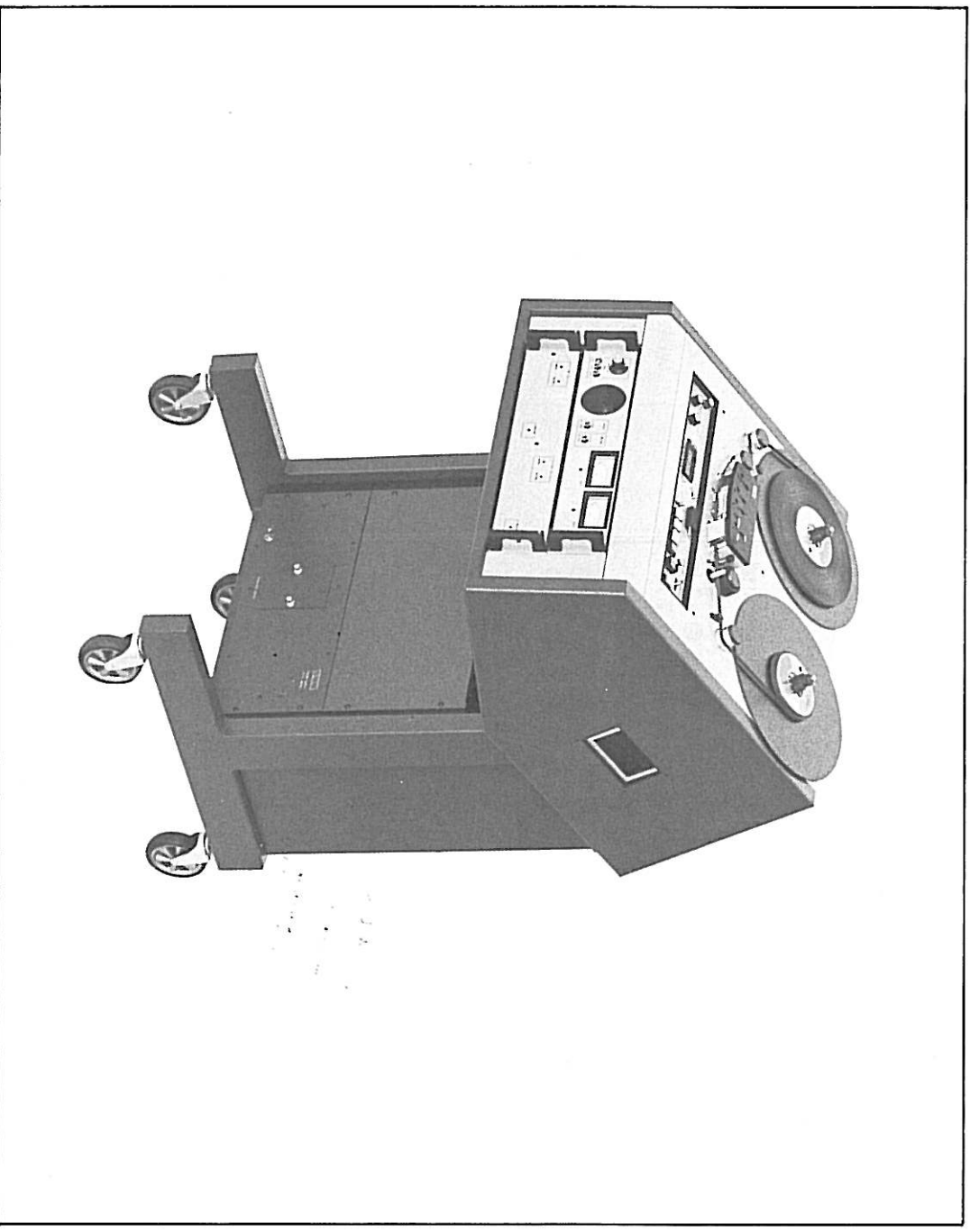

Figure 1-4 JH-110BC Transport

TABLE 1-3 SPECIFICATIONS
JH-110BC

Reel Size	30 cm max DIN	DIN hubs standard
	3 to 1 1/4 inch EIA or NAB	Reel locks optional
Tape Width	1/4 inch 2-track	DIN stereo
Tape Speeds		
Fixed	7 1/2 and 15 ips (19 and 38 cm/s)	Phase locked loop dc capstan control referenced to fixed crystal oscillator
Variable	2 to 22 ips (5 to 56 cm/s)	or variable VCO
Long Term Speed Stability	better than 0.02%	
Tape Tension	5 1/2 ± 1/4 oz. at all tape speeds beginning to end of reel	Measured between capstan and roller guide
Start Time	500 msec @ 15 ips 500 msec @ 7 1/2 ips	To 0.1% DIN 45507 flutter with 10 1/2 inch reels
Rewind Time	110 sec for 2500 ft. 170 sec for 4800 ft.	
Wow and Flutter	15 ips < 0.030% 7 1/2 ips < 0.045%	DIN 45507 weighted DIN 45507 weighted
Frequency Range		
Record/Reproduce (Using Ampex 456 tape)	15 ips, IEC 7 1/2 ips, IEC	30Hz to 20 KHz +0.75, -2dB 30Hz to 18 KHz +0.75, -1.5dB
Signal to Noise *		mono stereo
Record/Reproduce referenced to 510nWb/m	15 ips, IEC 7 1/2 ips, IEC	65 64 63 62
Weighted dB(A)	15 ips, IEC 7 1/2 ips, IEC	72 69 68 66
Weighted CCIR 468	15 ips, IEC 7 1/2 ips, IEC	62 60 58 56

TABLE 1-3 SPECIFICATIONS
(continued)

Harmonic Distortion*		
1kHz fundamental at 510 nWb/m		
3rd harmonic	15 ips, IEC 7½ ips, IEC	<0.52% <1.6%
2nd harmonic	15 ips, IEC 7½ ips, IEC	<0.10% <0.10%
3rd harmonic 3% fluxivity level	15 ips, IEC 7½ Ips, IEC	1020nWb/m 1000nWb/m
Depth of Erasure referenced to 250nWb/m	better than 80 dB at 1 kHz	
Bias and Erase Frequency	120 kHz	

* Typical values given. Specifications are largely dependent on tape formulation. Also, the performance of any particular type of tape varies from batch to batch.

1.2.6 JH-110M

The JH-110M is a three speed disc mastering deck intended for use with full and half revolution delay disc mastering systems. In addition to the standard JH-110B features, the mastering deck includes a tape delay, a fast motion limit control, and an enhanced RTZ IIIIM autolocator. Several tape roller guides provide time delays between the two playback heads. The tape path around these roller guides can insert a half or full revolution delay for 33-1/3 or 45 rpm discs at any of the three

tape speeds.

The fast motion limit potentiometer limits the maximum tape speed in the fast forward and reverse modes for gentler spooling. The RTZ IIIIM, along with the standard locating functions, stores positions for groove expansion, banding, and end of disc lead-out functions.

The JH-110M is available in 1/4 inch stereo and mono versions. Specifications for the JH-110M are listed in Tables 1-4.

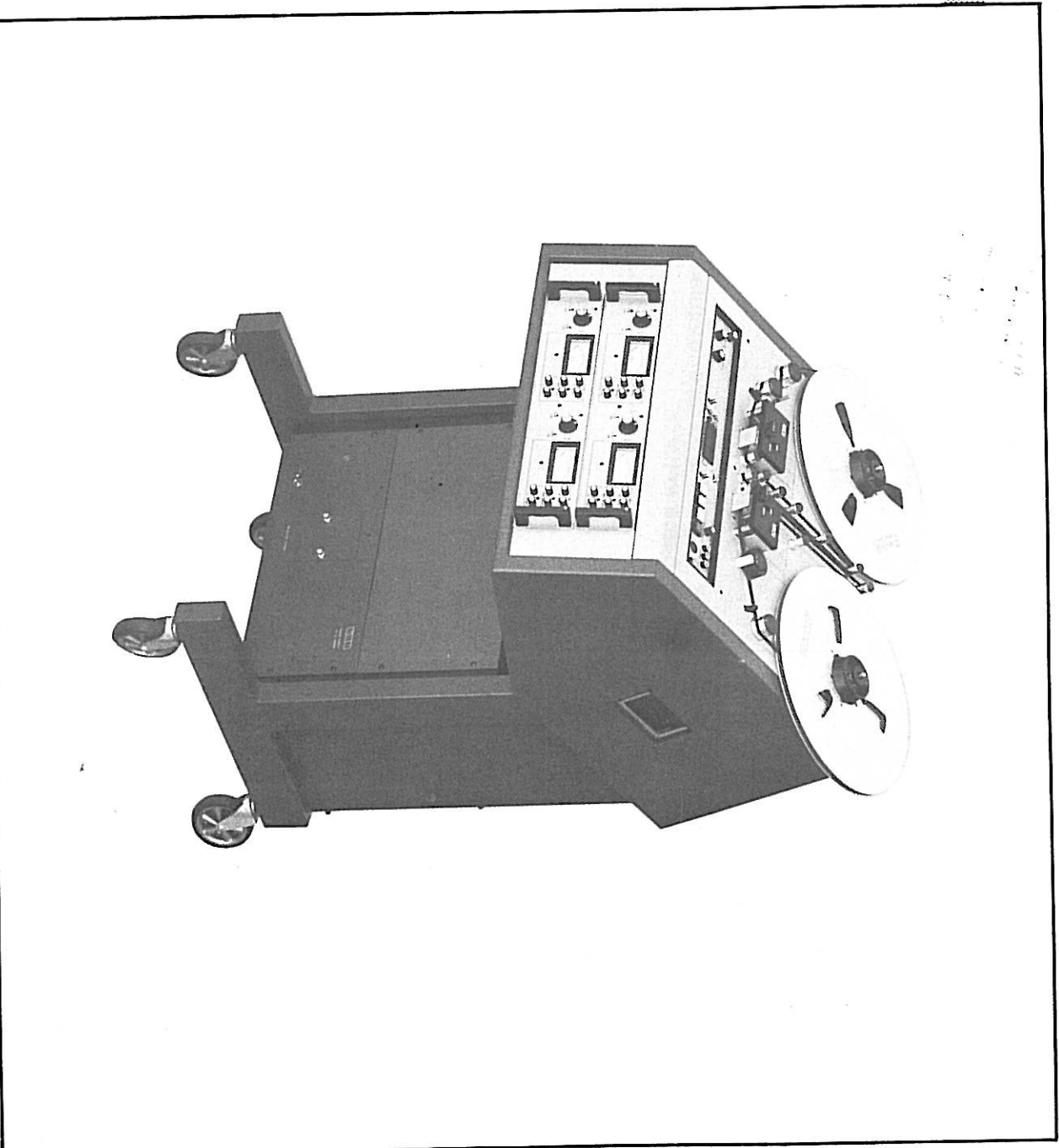

Figure 1-5 JH-110M Transport

TABLE 1-4 SPECIFICATIONS
JH-110M

Reel Size	3 to 14 inch NAB or EIA			
Tape Width	1/4 inch full width 1/4 inch 2 track NAB 1/4 inch 2 track DIN 1/2 inch 2 track			
Tape Speeds				
Fixed	7 1/2, 15, & 30 ips (19, 38 & 76 cm/s)	Phase locked loop dc capstan control referenced to fixed crystal oscillator or variable VCO.		
Variable	5 to 45 ips (13 to 114 cm/s)			
Long Term Speed Stability	better than 0.02%			
Tape Tension	5 1/2 ± 1/4 oz.	At all tape speeds beginning to end of reel		
Start Time	900 msec @ 30 ips 500 msec @ 15 ips 500 msec @ 7 1/2 ips	To 0.1% DIN 45507 flutter with 10 1/2 inch reels		
Rewind Time	variable 110 sec to 11 1/2 min. for 2500 ft.			
Wow and Flutter	30 ips < 0.020% 15 ips < 0.030% 7 1/2 ips < 0.045%	DIN 45507 weighted DIN 45507 weighted DIN 45507 weighted		
Frequency Range				
(Using Ampex 456 tape)	30 ips, AES 15 ips, NAB 7 1/2 ips, NAB	40Hz to 28 KHz 30Hz to 24 KHz 30Hz to 20 KHz	+0.75, -2dB +0.75, -2dB +0.75, -1.5dB	
Signal to Noise*	mono 2 track			
referenced to 510nWb/m	30 ips, AES 15 ips, NAB 7 1/2 ips, NAB	74 73 71	71 70 68	
Weighted dB(A)	30 ips, AES 15 ips, NAB 7 1/2 ips, NAB	87 81 81	84 78 78	

TABLE 1-4 SPECIFICATIONS (continued)

Harmonic Distortion*			
1kHz fundamental at 510 nWb/m			
3rd harmonic	30 ips, AES 15 ips, NAB 7½ ips, NAB	<0.35% <0.52% <1.6%	
2nd harmonic	30 ips, AES 15 ips, NAB 7½ ips, NAB	<0.10% <0.10% <0.10%	
3rd harmonic 3% fluxivity level	30 ips, AES 15 ips, NAB 7½ ips, NAB	1040nWb/m 1020nWb/m 1000nWb/m	
Delays			
Max delay time	30 ips 1.8 sec. 15 ips 3.6 sec. 7½ ips 7.2 sec. 3¾ ips 14.4 sec.		54 inch (137cm) delay Loop
Min delay time	30 ips 0.21 sec. 15 ips 0.46 sec. 7½ ips 0.84 sec. 3¾ ips 1.68 sec.		6.3 inch (16 cm) delay loop Delay may be set for several values between min and max.
1 Revolution			
Delay (Capps or Scully)	30 ips 54 ±.2 in. 15 ips 27 ±.2 in. 7½ ips 13.5 ±.2 in. 3¾ ips 34.3 ±.5cm	33½ RPM (1.8 sec)	45 RPM (1.33 sec)
1/2 Revolution			
Delay (Neumann)	30 ips 27 ±.2 in. 15 ips 13.5 ±.2 in. 7½ ips 6.7 ±.2 in. 3¾ ips 17.1 ±.5cm	33½ RPM (0.9 sec)	45 RPM (0.66 sec)

* Typical values given. Specifications are largely dependent on tape formulation. Also, the performance of any particular type of tape varies from batch to batch.

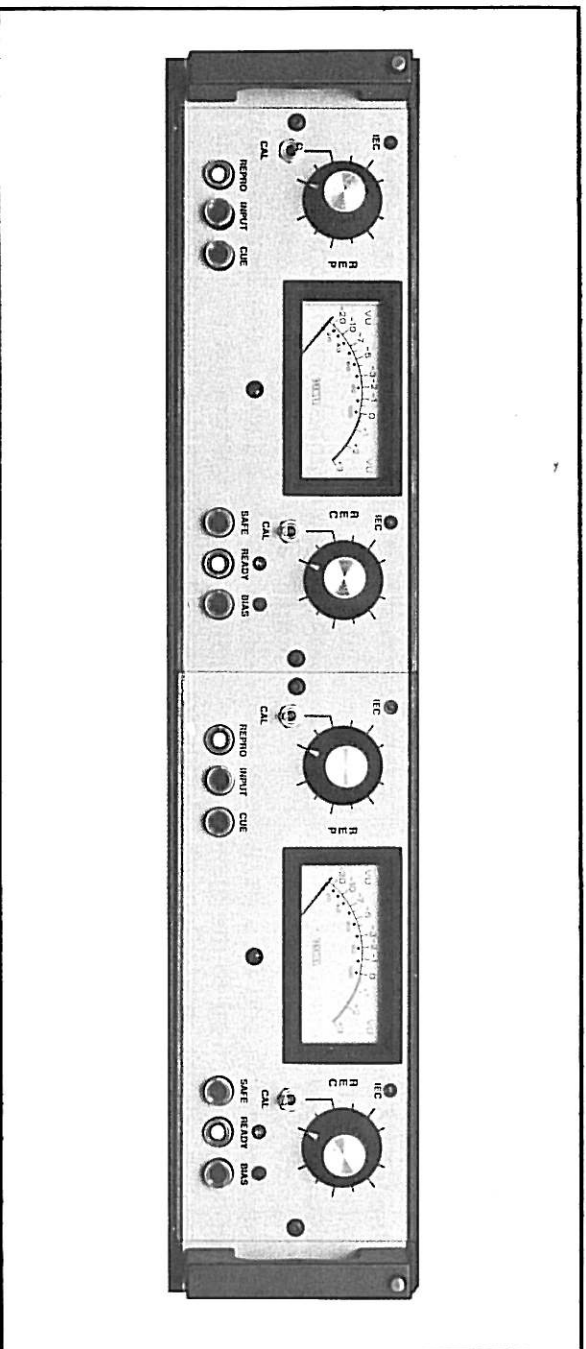

Figure 1-6 Audio Panel

1.3 Audio Electronics

1.3.1 Standard Audio Electronics (JH-110B,-14,-8)

The standard JH-110B audio electronics are housed inside a 3-1/2 by 17-3/4 by 12-1/8 inch drawer (8.9x45.1x30.8 cm). Each drawer holds two channels of audio electronics. Single track operations contain one channel mounted in the left side and a blank panel covering the right side of the drawer. Variable profile cabinets hold one or two drawers; high profile cabinets hold two or four. These drawers extend from the cabinets on latching slide rails for access to the audio printed circuit boards and components. Audio input, output, and power connectors are located at the rear of the drawers. The drawers can be extended on their slide rails without disconnecting any cables.

Each channel consists of a front panel, which sup-

ports the meter and switches, and a Mother Board, which forms the bottom of the assembly. The I/O, Record, Reproduce, and Bias circuit boards are plug in modules which mount directly onto the Mother Board. The channel electronics can be easily removed from the drawer by removing two screws in the front panel and four screws in the Mother Board. All connections to the Mother Board are made via plug in connectors. Since all the channel electronics are identical, modules can be swapped from channel to channel for troubleshooting or maintenance purposes.

Switches on the Repro and Record Modules select either NAB or IEC standard equalization. When properly aligned to specifications the equalization standards can be switched without any realignment necessary.

Specifications for the standard audio electronics are listed in Table 1-5.

1.3.2 Broadcast Audio Electronics (JH-110BC)

The broadcast audio electronics mount in two drawers similar to the standard audio electronics. The bottom drawer contains two channels of audio electronics, similar to the standard audio electronics. The top drawer contains the monitor amplifier and speaker plus the controls and meters.

Two track stereo or mono playback/record modes are switch selectable. The monaural mode records the left line input onto both right and left tracks. In repro both tracks are summed together and applied to the left line output.

The Mother Board, I/O, and Bias Modules of the broadcast deck are similar to the standard audio modules. The Repro and Record Modules however, are unique to this transport. These

**TABLE 1-5
STANDARD AUDIO SPECIFICATIONS**

Line Input	
Level	-15dBm to +24dBm for 0 VU
Input Impedance	10 k Ω balanced
Headroom	30dBm at clipping
Line Output	
Level	+4dBm at 0 VU
Source Impedance	120 Ω balanced
Maximum Output	+24dBm at clipping
Equalization	
High Speed	Low Speed Option
30 ips AES	15 ips NAB/IEC
15 ips NAB/IEC	7½ ips NAB/IEC
7½ ips NAB/IEC	3¾ ips NAB

modules playback and record at preset levels only, there are no repro or record level controls on the broadcast front panel. Also, since this is a two speed transport, the Repro and Record Modules contain only high and low speed equalization networks.

Specifications for the broadcast audio electronics are listed in Table 1-6.

1.3.3 Broadcast Audio Electronics (JH-110BX)

The JH-110BX audio electronics is similar to the standard audio electronics. It consists of either one or two channels mounted in a single drawer. Equalization is provided for two speeds, it is not instant standard switchable like the standard version. These electronics do not contain any cue mode repro circuitry. In addition to the audio electronics drawer, the JH-110BX can be ordered with an optional monitor amplifier drawer. This option provides a built in speaker and a headphone jack for monitoring the deck's output. A volume (level)

**TABLE 1-6
BROADCAST AUDIO SPECIFICATIONS**

Line Input	
Level	-15dBm to +24dBm for 0 VU
Impedance	10 k Ω bridging line balanced
Headroom	30dBm at clipping
Line Output	
Level	+6dBm at 0 VU
Source Impedance	150 Ω balanced, transformer coupled
Maximum Output	+24dBm at clipping
Equalization	
15 ips NAB/IEC	
7½ ips NAB/IEC	

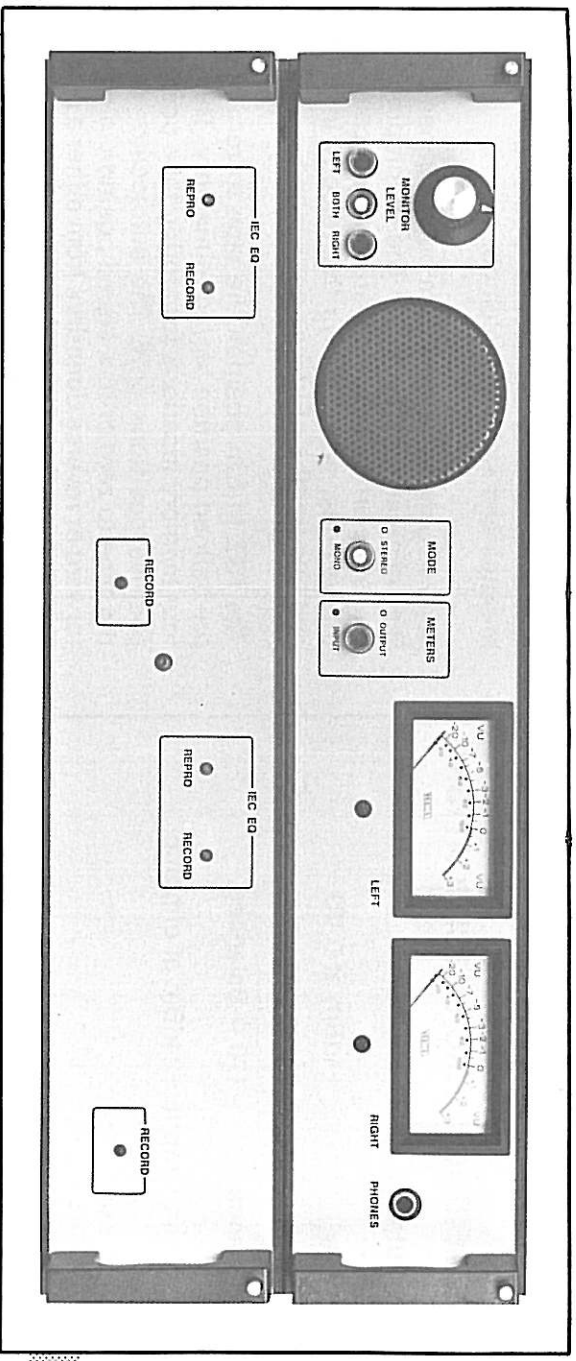

Figure 1-7 Broadcast Audio Panel

control and right/left/both switches are mounted on the monitor's front panel.

switch on the front panel can select preset equalization (NAB or IEC).

1.3.4 Mastering Audio Electronics (JH-110M)

The mastering deck audio electronics are mounted in extendible drawers similar to the standard audio electronics. Two identical channels fit into each drawer. The top drawer contains the repro circuitry for the preview head, the bottom drawer contains the repro circuitry for the repro head. High frequency and low frequency equalization controls for each of the three speeds are provided on the front panel. Alternatively, a

The Mother Board and Repro Modules of the mastering deck audio channels are similar to those of the standard audio channels. Modules unique to these audio electronics are the Front Panel Equalization Board and an output only version of the I/O Amplifier Module. Since this is a reproduce only machine, there are no Bias or Record Modules.

Specification for the mastering deck audio electronics are listed in Table 1-7.

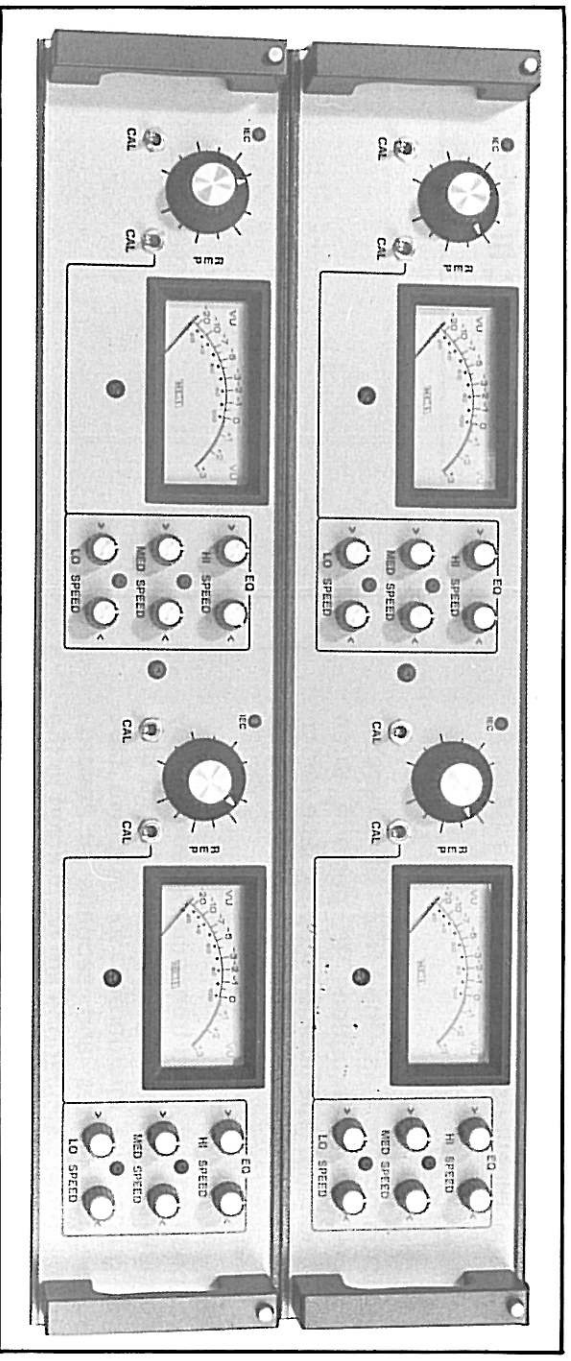

Figure 1-8 Mastering Audio Panel

**TABLE 1-7
MASTERING AUDIO SPECIFICATIONS**

Line Output	
Level	+4dBm at 0 VU
Source	120 Ω Balanced
Impedance	
Maximum Output	+24dBm at clipping
Equalization	
30 ips AES with front panel variable control	
15 ips NAB/IEC with front panel variable control	
7½ ips NAB/IEC with front panel variable control	

1.4 RTZ III and Autolocator III

The RTZ III autolocator is standard on all JH-110Bs. The JH-110M transports are equipped with the RTZ IIIM autolocator which has additional disc mastering control functions. The JH-110C eight track uses the Autolocator III, mounted in a remote control unit. All three locators are microprocessor controlled and have the same accuracy and range specifications. These specifications are listed in Table 1-8.

1.4.1 RTZ III

A microprocessor in the RTZ III executes firmware-stored subroutines to perform three basic functions: tape position display, tape velocity display, and reel motor control allowing relocation to any position on the tape.

Tape position is derived from pulses generated by an optical transducer mounted under the left tape roller guide. The microprocessor displays tape position in minutes and seconds of record/playback time. Calculations are normalized to the tape speed so that the display always indicates actual record/playback time for any standard speed selected. Negative time, that is, positions

on the tape to the left of the zero position, is indicated by a flashing decimal point between the minutes and seconds columns.

Tape velocity is derived from pulses generated by the capstan tachometer. The microprocessor times the arrival of the capstan pulses, calculates the velocity, and displays the velocity in inches and hundredths of inches per second.

The RTZ III can position the tape to zero or to a pre-defined position stored in memory. There are four memory locations for storing tape positions, positive positions only. The autolocator returns the tape to zero or to a stored position in either a forward or reverse direction, from either a positive or negative tape position. Tape positions can be stored in the memory locations at any time using switches on the display panel.

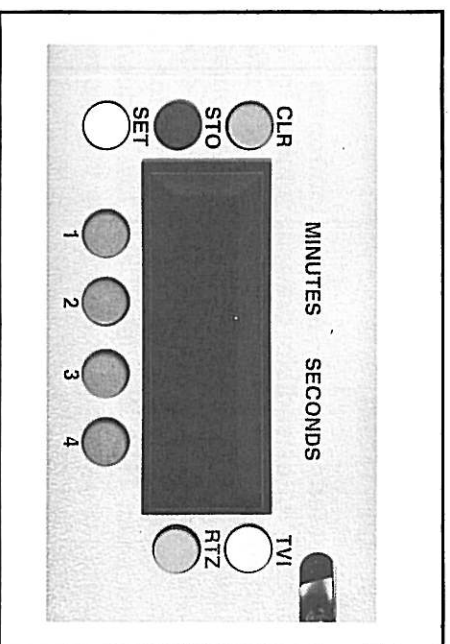

Figure 1-9 RTZ III Panel

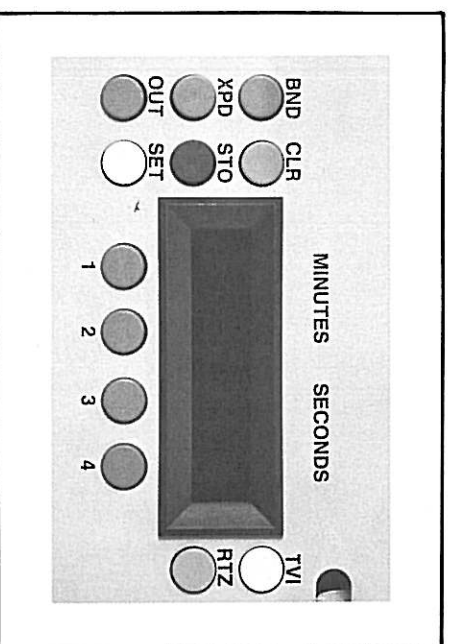

Figure 1-10 RTZ IIIM Panel

1.4.2 RTZ IIIM

The RTZ IIIM, found in the JH-110M transports, performs all the RTZ III functions plus three disc lathe control functions. Twenty additional memory locations are available for storing groove expansion positions, band positions, and the end of record lead out position. During playback the RTZ IIIM signals the disc lathe to perform the desired expand, band, or lead out function when the tape reaches the position stored in memory. The display will read out all the function positions stored in memory and indicate the number of unused locations available.

1.4.3 AutoLocator III

The AutoLocator III performs the same basic functions as the RTZ III and has several additional features. It contains ten position locate memories and uses two LED position displays. One display shows the tape position, the other shows the desired locate position. Tape positions are loaded into the display and the memory with a calculator type keyboard.

The AutoLocator III also allows remote variable speed control of the transport. In the variable speed mode, the tape velocity function displays both the tape speed and the number of semitones of pitch change.

1.5 Power Supply

The JH-110PS power supply converts single phase ac line voltage to the ac and regulated dc voltages required by the tape transport and the audio electronics. The power supply mounts at the bottom of cabinet and is secured by four allen head screws.

Located on the front panel are the ON/OFF power switch and an access door to the voltage regulators. On the rear panel are the power connectors and the fuse holder. The fuse holder plug sets the transformer for use with a 100, 115, or 220 volt ac line input at either 50 or 60 Hz.

Input power specifications for the JH-110PS are listed in Table 1-9.

**TABLE 1-8
RTZ III and A/L III
SPECIFICATIONS**

Position Memories	
RT III	4 locate memories
RTZ IIIM	4 locate memories plus 20 lathe function memories
A/L III	10 locate memories
Position Range	-99 min 59 sec to +99 min 59 sec
Locator Accuracy	±1 sec accumulative over 20 locates
Velocity Range	0 to 50 ips
Velocity Display Accuracy	±0.01 ips

**TABLE 1-9
INPUT POWER SPECIFICATIONS**

INPUT VOLTAGE (50-60Hz)	TOLERANCE	CURRENT DRAW	POWER DISSIPATION	HEAT DISSIPATION	FUSE TYPE
100V	±10%	2.2A	220W	750BTU/hr	115v 4A S/B
115V	±10%	2.0A	220W	750BTU/hr	115v 4A S/B
220V	±10%	1.0A	220W	750BTU/hr	220v 2A S/B

**TABLE 1-10
ORDERING NUMBERS**

MODEL NUMBER	DESCRIPTION
RECORDING SYSTEMS (includes RTZ III)	
JH-110B-1-UM	Monaural recorder 1/4 inch
JH-110B-1/2-UM	Monaural recorder 1/4 inch with additional two track playback head and electronics
JH-110B-2-UM	Two-track recorder 1/4 inch
JH-110B-2/1-PB-UM	Two-track recorder 1/4 inch with additional monaural playback head and electronics
JH-110B-2/2-PB-UM	Two-track recorder 1/4 inch with additional 1/4 track stereo playback head and electronics
JH-110B-4-UM	Four-track recorder 1/2 inch
JH-110B-14-1-UM	Monaural recorder 1/4 inch, 14 inch reels
JH-110B-14-1/2-PB-UM	Monaural recorder 1/4 inch with additional two-track playback head and electronics, 14 inch reels
JH-110B-14-2-UM	Two-track recorder 1/4 inch, 14 inch reels
JH-110B-14-2/1-PB-UM	Two-track recorder 1/4 inch with additional monaural playback head and electronics, 14 inch reels
JH-110B-14-2/2-PB-UM	Two-track recorder 1/4 inch with additional 1/4 track stereo playback head and electronics, 14 inch reels
JH-110B-14-4-UM	Four-track recorder 1/2 inch, 14 inch reels
JH-110C-8	Eight-track , 1 inch, 10 1/2 inch reels
PLAYBACK ONLY SYSTEMS	
JH-110B-1-PB-UM	Monaural reproducer 1/4 inch
JH-110B-2-PB-UM	Two-track reproducer 1/4 inch
JH-110B-4-PB-UM	Four-track reproducer 1/2 inch
JH-110B-14-1-PB-UM	Monaural reproducer 1/4 inch, 14 inch reels
JH-110B-14-2-PB-UM	Two-track reproducer 1/4 inch, 14 inch reels
JH-110B-14-4-PB-UM	Four-track reproducer 1/2 inch, 14 inch reels
BROADCAST SYSTEMS	
JH-110BC-UM	DIN stereo recorder 1/4 inch, 30cm reels
JH-110BX-1-UM	Monaural recorder 1/4 inch, 10 1/2 inch reels
JH-110BX-2-UM	Two-track recorder 1/4 inch, 10 1/2 inch reels
TAPE TO DISK TRANSFER SYSTEMS (reproduce only)	
JH-110M-1-C-UM	Monaural system for Capps lathe
JH-110M-1-N-UM	Monaural system for Neumann lathe
JH-110M-1-S-UM	Monaural system for Scully lathe
JH-110M-2-C-UM	Stereo system for Capps lathe
JH-110M-2-N-UM	Stereo system for Neumann lathe
JH-110M-2-S-UM	Stereo system for Scully lathe
CABINETS	
VP	Variable profile cabinet
VP-M	Variable profile cabinet for JH-110M
HP-4	Overhead bridge cabinet, two tier
HP-8	Overhead bridge cabinet, four tier

1.6 Options

Table 1-10 lists the ordering numbers for the various JH-110B models and options. Model number suffix codes attached to the ordering numbers are defined as follows:

- 1 — 1/4 inch full track
- 2 — 1/4 inch two track
- 4 — 1/2 inch four track
- UM — unmounted
- VP — with variable profile cabinet
- HP — with high profile cabinet
- PB — playback only electronics

The following options are available for the JH-110B. Some options are not available on some models. Check price lists for restrictions.

- Option 1 — low speed transport
- Option 2 — DIN format stereo heads
- Option 3 — tape scissors and marker
- Option 4 — RTZ III autolocator
- Option 5 — technical manual
- Option 6-1 — transformer line outputs
- Option 6-2 — transformer line inputs and outputs
- Option 7-1 — 1/2-inch format stereo heads
- Option 7-M — 1/2-inch format stereo heads for the JH-110M

1.7 Accessories

Monitor Panel JH-110B-MON

The Monitor Panel allows you to monitor the tape machine's output through a built in speaker or a mono headphone jack. This panel contains a volume control and left/right/both channel select switches. The panel and its amplifier occupies the space of a standard electronics drawer. It may be installed in any JH-110 transport containing an empty electronics drawer.

A schematic of the monitor's amplifier, PCA2700-0059, is included in Section 5.

Remote Control JH-110B-R/C

The remote control unit provides full transport motion control. Controls included are: fast forward, rewind, stop, play, record, edit, tape lifter defeat, return to zero, RTZ display reset, and an MVC joystick. The lifter defeat, not found on the

transport, prevents the tape lifters from pushing the tape away from the heads during the fast wind modes.

The remote control plugs directly into the transport via a 35 foot long cable.

This accessory is not compatible with the JH-110C-8.

Cover Plate JH-110B-HA/CP

This cover plate mounts on the top of the head bridge assembly and prevents access to the head adjustment screws.

Accessory Stand JH-20

The JH-20 holds one remote control unit, one AutoLocator III, or one JH-45 AutoLock.

Mounting Bracket JH-20-3

The JH-20-3, when connected to the JH-20 Accessory Stand, holds up to three JH-110B-R/C remote control units.

Accessory Stand JH-21

This larger stand holds, side by side, two AutoLocators, two AutoLocks, or one of each.

Phase Meter JH-22

The JH-22 Phase Meter comes housed in its own chassis that includes its own power supply. The meter reads from -180 to +180 degrees.

Remote Readout JH-47

The JH-47 is a remote display for the RTZ III. This accessory includes a four digit LED display, a bezel cover for the display, and a 35 foot cable. You must supply your own mounting surface or enclosure for the display.

Schematics for the JH-47 are included in Section 4.

Tape Path Alignment Kit ASS6B79

This kit contains precision machined blocks for aligning the heads and the tape guides. It is not intended for use with 1/4 inch tape transports.

Annunciator Board 25B177

DIN Hub Adaptors JH-110-D/H

This board is a troubleshooting aid for the transport. LEDs on this board indicate the output states of several key control signals from the Control Logic Board. A description of this board and its use is given in Section 8.

Accessory JH-110-D/H is a set of two DIN hub adaptors and tape platters for 1000m tape pancakes.

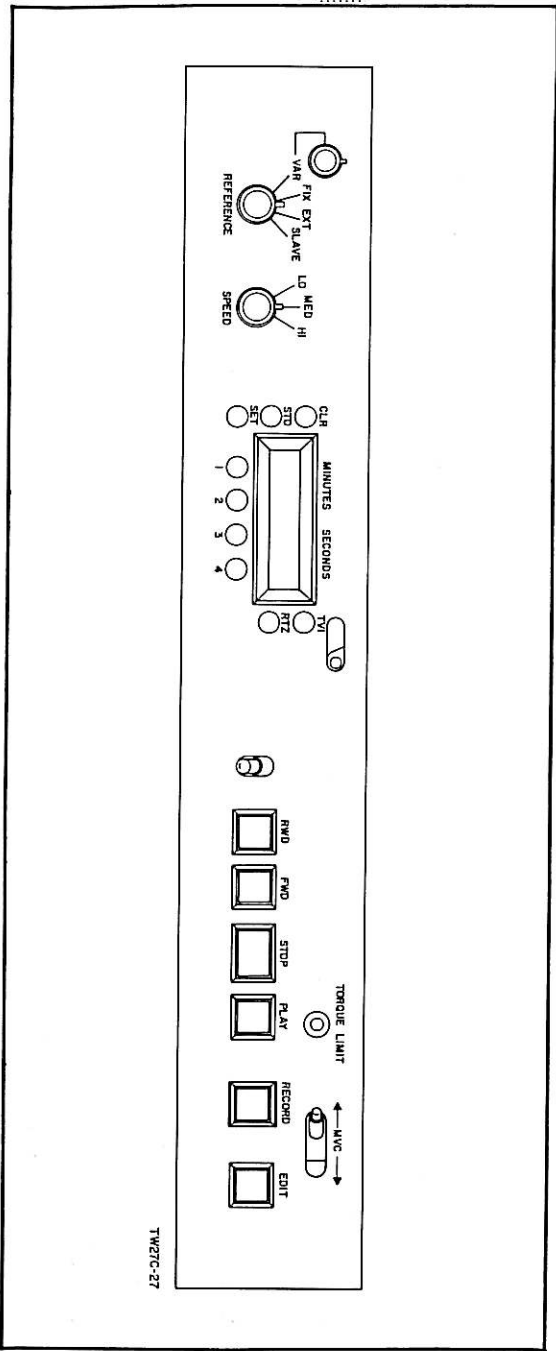

Figure 2-1 Transport Control Panel

SECTION 2

OPERATING PROCEDURES

This section lists all the control switches and indicators of the tape transport and the audio electronics. Several examples of the use of these controls follow these lists. These examples can be used to familiarize yourself with the operation of the tape recorder or as a post installation check-out procedure to insure proper operation. For detailed maintenance and alignment procedures, consult Section 7 of the Technical Manual.

2.1 CONTROLS & INDICATORS

Control/Indicator

Transport

RWD

Rewinds tape onto supply reel at fast speed. Cancels previously selected motion command (i.e. FWD, PLAY, or RECORD).

FWD

Winds tape onto take-up reel at fast speed. Cancels previously selected motion command.

STOP

Cancels previously selected motion command and stops tape.

PLAY

Initiates playback at the selected speed and cancels previous motion command (RWD, FWD, STOP, or RECORD). Playback source is selected at the audio panel.

RECORD

When pressed with PLAY button, or when in play mode, enables recording at selected

speed. To record, RECORD READY must also be selected at the audio panel.

EDIT

When pressed with tape out of the tape load sensor, unspools tape from supply reel without winding it onto the take-up reel. Tape spills off right side of deck for editing and stops when STOP is pressed.

When pressed with tape in the tape load sensor, disables the tape tension system. Tape then moves freely by hand with no resistance from the reel motors. If the tape has remained in the tape load sensor during this mode, tension is restored by pressing EDIT a second time. If the tape is removed from the tape load sensor during this mode, tension is restored by replacing the tape in the tape load sensor.

FAST MOTION LIMIT (110M Only)

Adjusts the maximum limit of the fast forward and rewind speeds, as well as maximum RTZ speed.

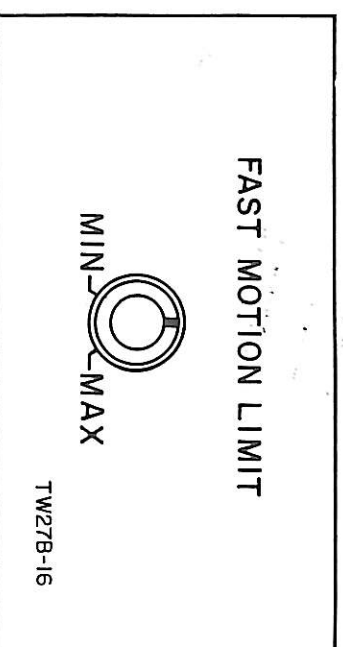

Figure 2-2
JH-110M Fast Motion Limit Control

MVC.

From stop mode, manually controls tape speed and direction while hand is in contact with joystick. When released, returns transport to STOP.

From rewind or fast forward modes, manually controls tape speed and direction if touched and will continue to control tape motion when released. Control cancelled when any other mode is entered.

TORQUE LIMIT SWITCH

Ten inch models — single switch. When out, selects normal torque, for 10-1/2 inch reels. When pressed in, limits reel motor torque for use with smaller or plastic reels.

Fourteen inch models — three switches:

HI — When pressed in, selects higher torque for use with 14 inch reels.

MED — When pressed in, selects standard torque for use with 10-1/2 inch reels.

LO — When pressed in, limits torque for use with smaller or plastic reels.

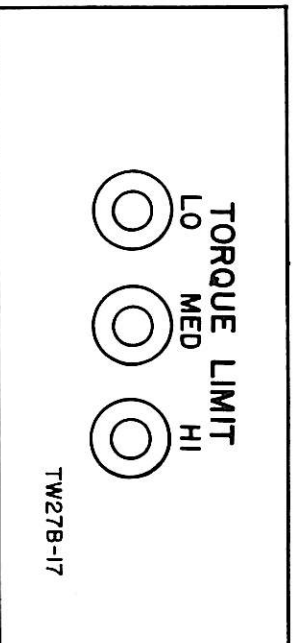

Figure 2-3

JH-110B-14 Torque Limit Switches

SHIELD LEVER

Raises and lowers repro head/shield.

TAPE LIFTER LEVER

Momentarily places tape against heads during fast forward and rewind modes.

SPEED SELECT

Three position switch:

HI — Selects high play and record speed (high speed models 30 ips, low speed models 15 ips)

MED — Selects medium play and record speed (high speed models 15 ips, low speed models 7-1/2 ips)

LO — Selects low play and record speed (high speed models 7-1/2 ips, low speed models 3-3/4 ips)

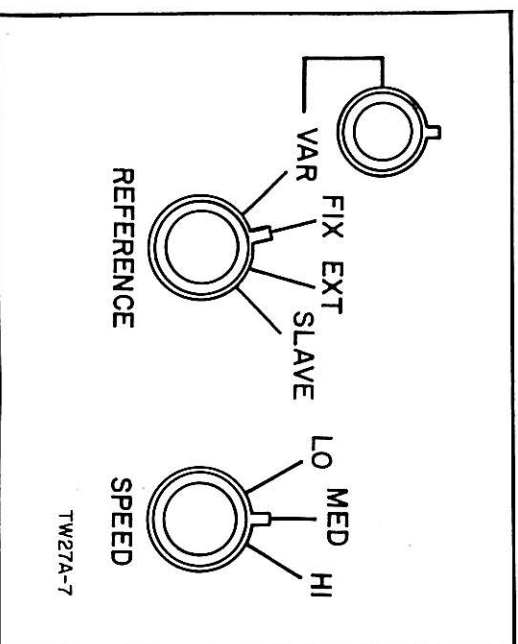

Figure 2-4

Reference And Speed Controls

REFERENCE SELECT

Four position switch:

EXT — Selects an external capstan speed reference for slaving this transport to another device.

FIX — Selects an internal crystal oscillator as a fixed reference for the capstan speed.

VAR — Selects a variable reference for the capstan speed.

SLAVE — Selects interface for use with MCI's AutoLock SMPTE synchronizer.

VARIABLE REFERENCE ADJUST

Varies the capstan speed by $\pm 20\%$ of the selected speed when VAR is selected by the reference switch.

RTZ III

RTZ III DISPLAY

Displays tape position in minutes and seconds of elapsed play/record time. Also used as display for RTZ function switches listed below.

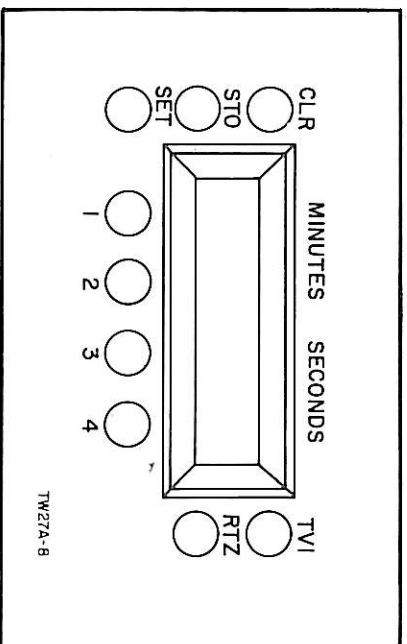

Figure 2-5 RTZ III Controls

TVI

Displays tape velocity in inches and hundredths of inches per second.

RTZ

Autolocates tape to the position where zero was set.

CLR

Clears display and defines present tape position as zero.

STO

Stores displayed tape position in the memory selected by switch 1, 2, 3, 4, BND, XPD, or L-OUT.

SET

Allows switches 1, 2, 3, and 4 to enter a tape position into the display.

1, 2, 3 & 4

Autolocates tape to the position stored in memory 1, 2, 3, or 4.

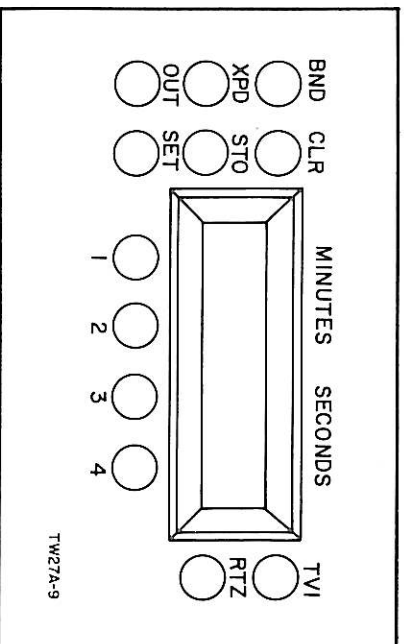

Figure 2-6 RTZ IIIM Controls

If SET is held down, pressing 1, 2, 3, or 4 increments the display digit located directly above the button. If STO were pressed, pressing 1, 2, 3, or 4 stores the displayed position in memory 1, 2, 3 or 4 respectively.

BND (110M Only)

Displays positions of BAND functions stored in memory. If STO were pressed, pressing BND stores the displayed position as a BAND position.

XPD (110M Only)

Displays the starting followed by the ending positions of the expand functions stored in memory. If STO were pressed, pressing XPD stores the displayed position as an expand starting position; releasing XPD stores the displayed position as an expand ending position.

L-OUT (110M Only)

Displays the position of the lead out function stored in memory. If STO were pressed, L-OUT stores the displayed position as the lead out position.

CLR (110M Only)

When pressed simultaneously with SET, clears the display to zero. If BND, XPD, or L-OUT were pressed, clears last displayed entry from memory.

Audio

REP Level

Controls level of the line output signal while REPRO is selected.

REP CAL

When in CAL position, disables the function of the REPRO level control and selects a preset calibrated level for output.

INPUT

Selects the line input as the source of the line output.

REPRO

Selects the reproduce head as the source of the line output.

CUE

Selects the record head as the source of the line output during playback. Selects line input

during recording.

mode.

REC Level

Controls the signal level to the record head for recording.

RECORD (Red)

When on, indicates that track and transport are in record mode.

REC CAL

When in CAL position, disables function of REC level control and selects a preset calibrated record level.

JH-110BC Only

Monitor

Level
Adjusts volume of monitor speaker and head-
phone outputs.

SAFE

Disables track erasing and recording when transport is switched to record mode.

Left

Selects left channel as monitor output to speaker.

READY

Enables track erasing and recording.

Both

Selects combination of left and right channels as monitor output to speaker.

2 BIAS

Displays relative level of bias current on VU meter.

IEC (Green)

When off, indicates that NAB equalization is selected on the Record and/or Repro Modules.

Mode

IN — Selects mono recording and playback.
OUT — Selects stereo recording and playback.

When on, indicates that IEC equalization is selected on the Record and/or Repro Modules.

READY (Amber)

When on, indicates that track is in record ready.

Meters

IN — Selects line input signal for meter display.

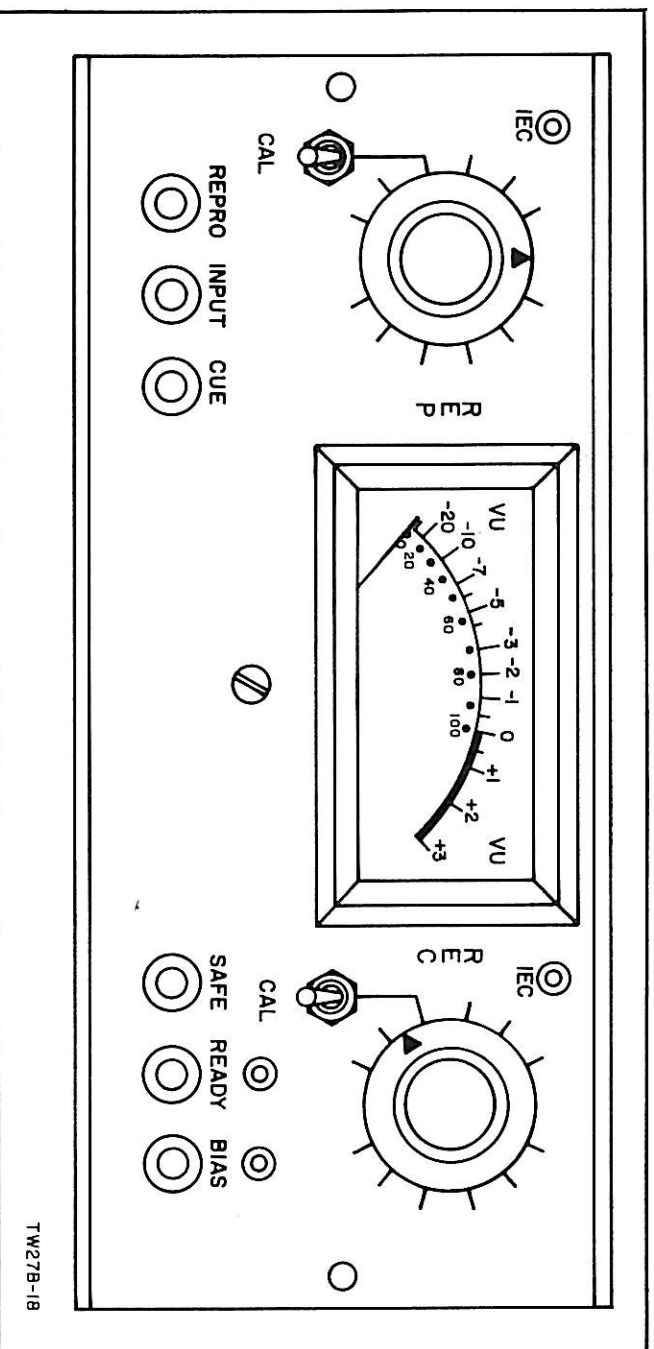

Figure 2-7 Audio Controls and Indicators

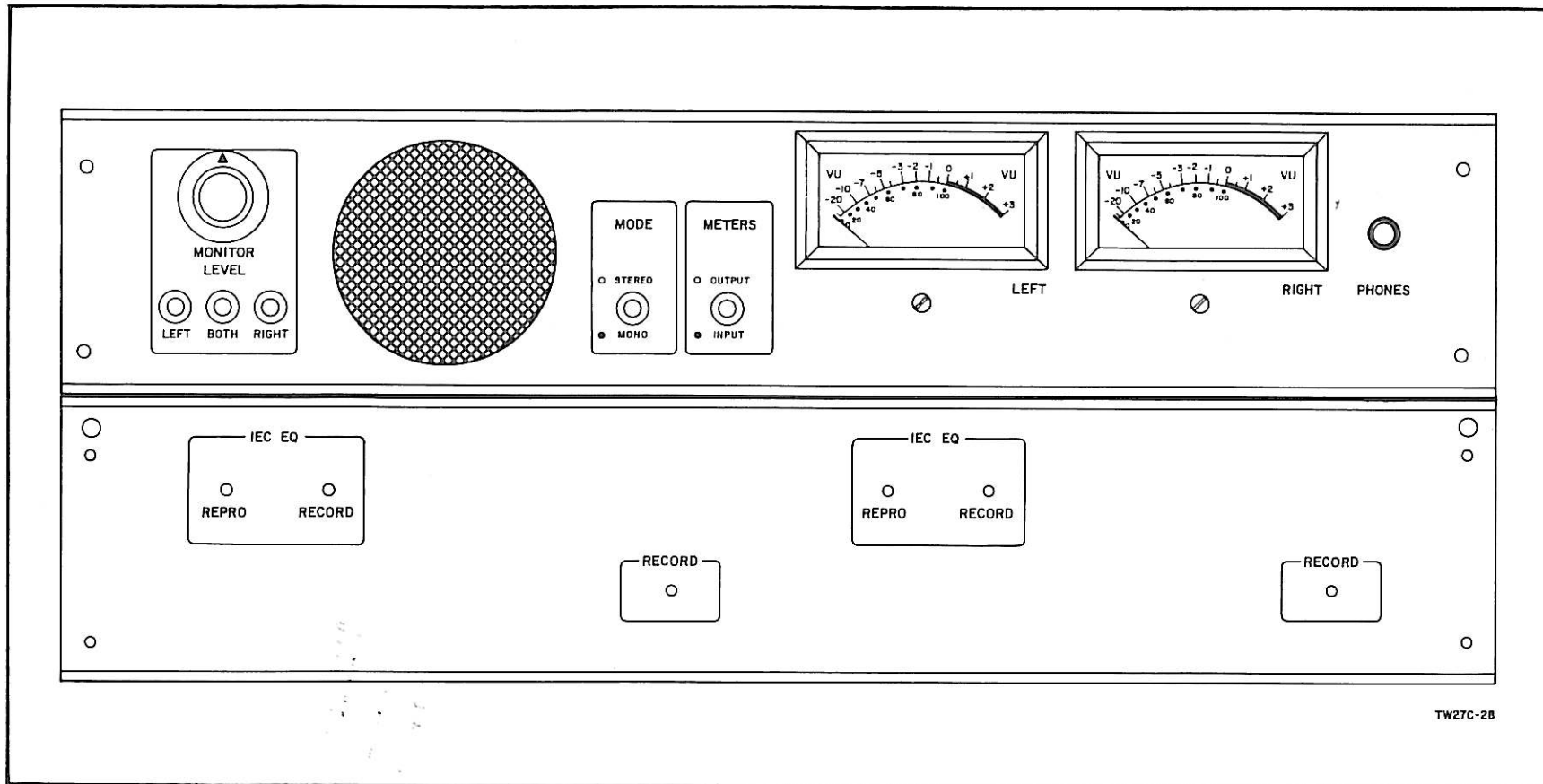

Figure 2-8 Broadcast Audio Controls and Indicators

OUT — Selects repro head output for meter display.

Phone
Jack for low impedance headphones, disables monitor speaker output.

JH-110C-8 Only

Individual Channel Status

NOTE: For remote status operation, the Remote Enable switch on each channel Audio Mother Board must be pressed in.

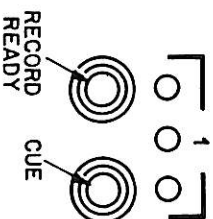

RECORD READY (Black Button)
Enables recording on that particular track.

CUE (Gray Button)
Selects the record head for playback.

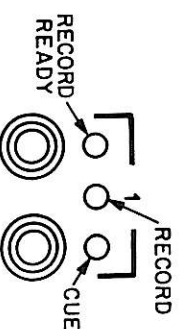

READY INDICATOR (Yellow LED)
Indicates that channel is in record ready mode.

RECORD INDICATOR (Red LED)
Indicates that channel is recording.

JH-110M Only

HI SPEED

< Adjusts high end equalization for high speed (30 ips).

> Adjusts low end equalization for high speed (30 ips).

MED SPEED

< Adjusts high end equalization for medium speed (15 ips).

> Adjusts low end equalization for medium speed (15 ips).

LO SPEED

< Adjusts high end equalization for low speed (7-1/2 ips).

> Adjusts low end equalization for low speed (7-1/2 ips).

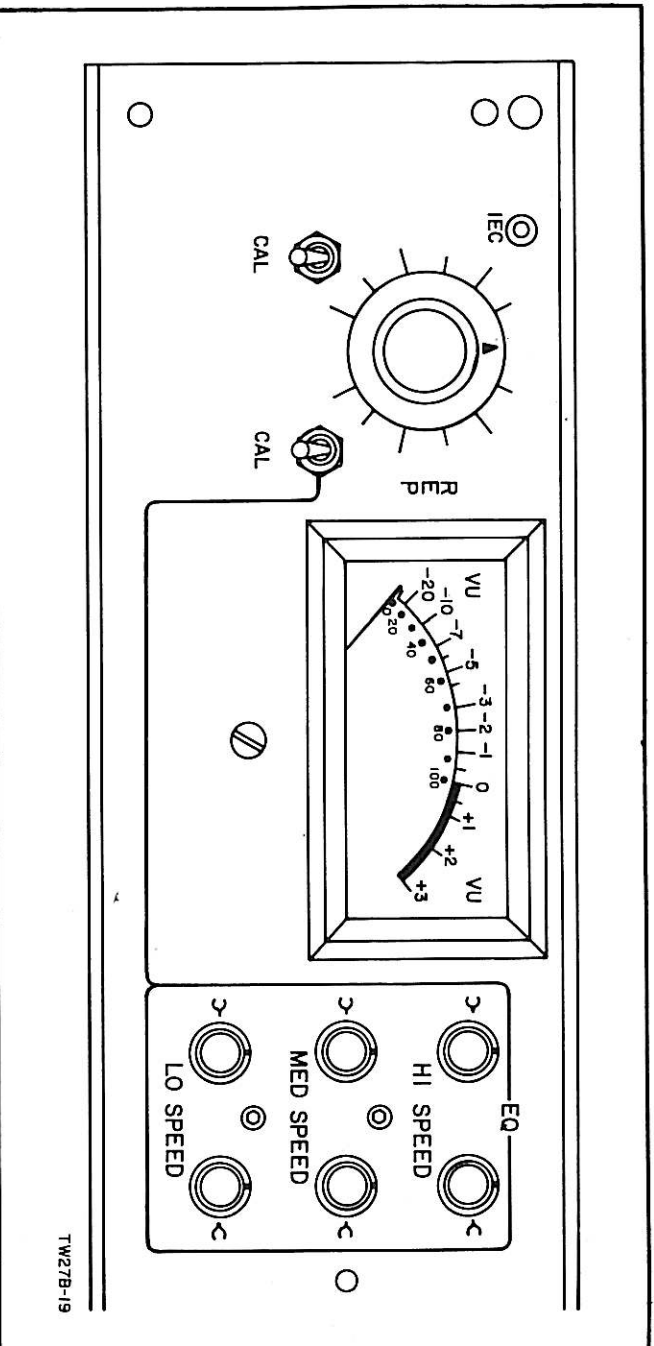

Figure 2-9 Mastering Audio Controls and Indicators

CUE INDICATOR (Green LED)

Indicates that channel playback signal is coming from the record head (cue or sync mode).

Master Status



TAPE INPUT AUTO

TAPE

Selects the repro or record head as source for line output and VU meters.



TAPE INPUT AUTO

INPUT

Selects the line input signal as the source for the line output and VU meters.



TAPE INPUT AUTO

AUTO

Selects automatic overdub operation. Monitor source for all channels in record ready status switch as follows:

Stop mode — input

Play mode — cue

Record mode — input

Monitor source for all other channels is cue (record head).



TAPE INPUT AUTO

INPUT/AUTO

Monitor source for all channels in record ready status is the input.

Monitor source for all other channels is cue (record head).

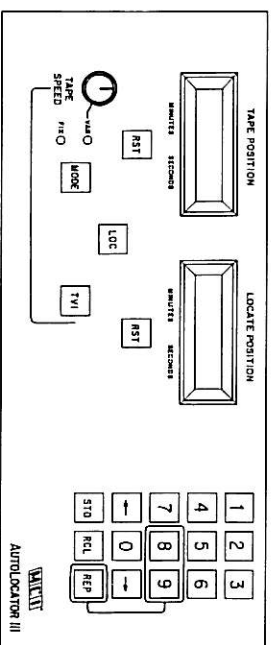

Autolocator III

TAPE POSITION DISPLAY

Displays the present tape position in minutes and seconds or tape velocity in inches per second.

LOCATE POSITION DISPLAY

Displays the autolocate position in minutes and seconds or pitch change in $\frac{1}{4}$ semitones from standard speed.



NUMERIC KEYBOARD (0 through 9)

Each switch enters its corresponding digit into the Locate Position display and memory.



Shifts Locate Position to Tape Position.



Shifts Tape Position to Locate Position.



STO

Stores the Locate Position into memory selected by numeric key.



RCL

Recalls position stored in memory selected by numeric key and displays it in the Locate Position display.

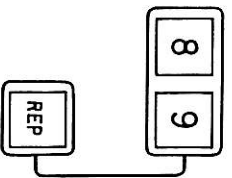

8/9/REP

Repeatedly returns tape to locate position 8 and plays to locate position 9. Cancelled by any function key.



RST

Clears position display and memory to zero.



LOC

Starts autolocation to position in Locate Position display.

Tape Speed Control



TVI

Displays tape velocity in inches per second in the Tape Position display and pitch change in ¼ semitone increments in the Locate Position display.



MODE

Selects either fixed or variable capstan speed reference when transport reference switch is in EXT position.

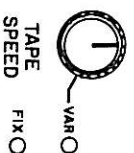

TAPE SPEED FIX ○
 VAR ○

TAPE SPEED

Varies the capstan speed when variable speed reference is selected by MODE switch.

VAR INDICATOR (Red LED)

Indicates variable capstan speed reference.

FIX INDICATOR (Green LED)

Indicates fixed crystal capstan speed reference.

2.2 Operating Procedures

2.2.1 Transport Motion Controls

Turn the Power Switch ON. (Located inside the well at the bottom of the cabinet.)

Meter lights come ON. All transport function lights are OFF.

Insert an opaque card into the Tape Sensor Slot.

The yellow light comes ON under the STOP button. The takeup reel starts turning counterclockwise. The supply reel starts turning clockwise. The speed of rotation for both reels is approximately 20 rpm — or about 1 turn in 3 seconds. The speed need not be identical for the two reels.

Remove the card. Load a roll of tape.

STOP light is ON. Reels wind up loose tape and establish idle tension.

Press the FWD button.

STOP light goes OFF. FWD light comes ON. Tape lifters lift tape away from the heads. The tape accelerates to a fast movement in the FWD direction.

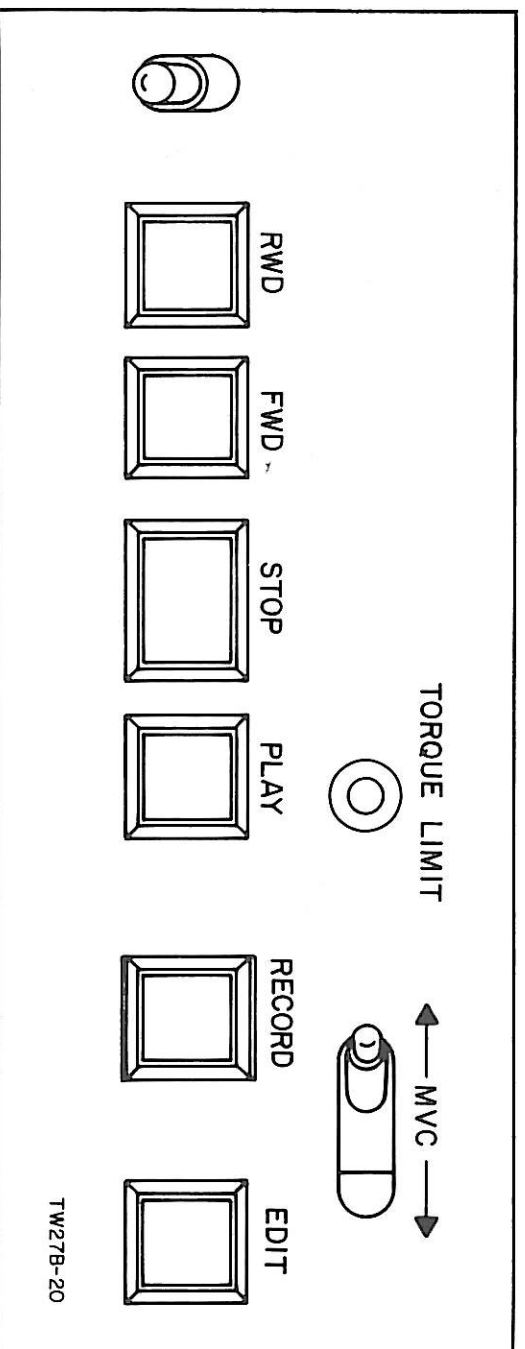

Figure 2-10 Transport Motion Controls

Press the RWD button.

FWD light goes OFF. RWD light comes ON. Tape slows smoothly and reverses direction, then accelerates in a rewind direction.

Press the STOP button.

RWD light goes OFF. STOP light comes ON. Tape lifters go to their recessed position.

Slowly move the MVC (Manual Velocity Control) Joystick to the right.

LED located in the joystick comes ON. Tape moves forward. (Speed of movement is directly related to the angle of the joystick.)

NOTE:

The Joystick may not work if good hand contact is not made to the surface of the tape transport. Contact may be made with either hand.

Slowly move the MVC Joystick to the left.

Tape comes to a stop and then moves in the reverse direction. Speed of the movement is directly related to the angle of the Joystick.

Release the MVC Joystick.

MVC LED turns OFF. Tape stops.

Touch (do NOT move) the MVC Joystick.

Tape starts in the same direction and at the same speed which was set when the Joystick was last used.

Set the MVC Joystick to some intermediate for-

ward speed — then release it.

MVC LED turns OFF. Tape stops.

Press the FWD button.

STOP light goes OFF. FWD light comes ON. Tape lifters come forward. Tape accelerates to full speed forward.

Touch (do NOT move) the MVC Joystick.

MVC LED comes ON. Tape slows to the intermediate speed already established by the position of the MVC Joystick.

Release the MVC Joystick.

Nothing changes. Tape continues to move. MVC LED stays ON. This is known as Latching MVC Mode.

Press any (except EDIT or REC) transport control button.

Machine drops out of latched MVC mode and enters the mode selected. MVC LED goes OFF.

Press the STOP button.

STOP light comes ON. Tape stops.

Press the PLAY button.

STOP light goes OFF. PLAY light comes ON. Capstan pressure roller clamps tape to the capstan. Tape moves at selected play speed.

Press the RWD button.

PLAY light goes OFF. RWD light comes ON. Capstan pinch roller releases tape. Tape lifters lift tape away from heads. Tape accelerates in

the rewind direction.

Press the PLAY button.

RWD light goes OFF. Both STOP and PLAY lights come ON. Tape stops. STOP light goes OFF. Tape lifter goes to its recessed position. Capstan pinch roller clamps tape to the capstan. Tape smoothly accelerates to selected play speed.

CAUTION

The following step will result in erasure of any material which has been recorded on the tape.

2

Press the RECORD button. (On the broadcast transport press both PLAY and RECORD)

RECORD light comes ON. (PLAY light is still ON.)

NOTE:

Transport is in Record mode. However, on the JH-110B decks ONLY channels which have been put into Record-Ready will make a recording.

Press the RWD button.

RECORD light and PLAY light go OFF. RWD light comes ON. Capstan pinch roller releases tape. Tape stops. Tape lifters lift tape away from heads. Tape accelerates in rewind mode.

Allow tape to rewind completely.

As soon as the tape pulls away from the takeup reel, it comes out of the tape sensor slot. All transport lights go OFF. Mechanical brakes come ON. RTZ Display freezes at end of tape position.

Thread the tape across the heads, through the capstan assembly, but NOT through the tape sensor slot.

Allow the end of the tape to spill over the right side of the tape transport.

Press the EDIT button.

EDIT light comes ON. Capstan pinch roller pulls tape against the capstan. Tape spills over the right side of the tape transport. The takeup reel is not activated. (This reel may creep slowly.)

Press the STOP button.

EDIT light goes OFF. Capstan pinch roller releases tape. Tape stops moving.

Retread the tape through the tape sensor slot and around the takeup reel.

EDIT light goes OFF. Reels turn at idle speed and take up any slack tape.

Press the EDIT button.

EDIT light comes ON. Reel stops.

Pull tape out of the tape sensor and to the right.

EDIT light stays ON. Reel motors give no resistance to tape movement, and turn easily in either direction.

Replace tape in tape sensor slot.

EDIT light goes OFF. Reels turn at idle speed and take up any slack in tape.

2.2.2. Reference and Speed Controls

Load a roll of tape.

Turn the REFERENCE switch to VAR.

Turn the SPEED switch to HI.

Press the LO TORQUE LIMIT switch (14 inch model).

Press the TORQUE LIMIT switch (10 inch model).

Put the transport into PLAY Mode.

Press and hold the TVI switch.

Slowly rotate the VAR potentiometer.

Note the speed variation between minimum and maximum position of the potentiometer. The speed range will be from -20% to +20% of the high speed mode of your machine.

Turn the SPEED switch to MED.

The transport goes into STOP mode.

Put the transport into PLAY mode.

Press and hold the TVI switch.

Slowly rotate the VAR potentiometer.

The speed variation will be $\pm 20\%$ of the MED speed of your machine.

Repeat the above procedure for LO speed.
The speed variation will be $\pm 20\%$ of the LO speed of your machine.

Turn the REFERENCE switch to FIX.

The speed will be the lowest fixed speed provided for your machine. (7-1/2 ips for the standard machine, 3-3/4 ips for the low speed option.)

Turn the VAR potentiometer.

There is no change of speed. Note that this potentiometer affects speed ONLY when the REFERENCE switch is in the VAR position.

Repeat the above procedure for MED and for HI speeds.

Speeds will be 15 ips and 30 ips for the standard machine. Speeds will be 7-1/2 ips and 15 ips for the slow speed machine. Note that the machine automatically switches to STOP when the SPEED switch is turned.

Turn the SPEED control to HI.

Press the LO TORQUE LIMIT switch (14 inch model).

Press the TORQUE LIMIT switch (10 inch model).

Hold a finger against the back of the tape between the right roller guide and the takeup reel.

Press FWD then RWD. Continue to rock back and forth between the two modes.

Feel the amount of tape tension developed during acceleration of the tape in a new mode.

Press the HI TORQUE LIMIT switch (14 inch model).

Put the TORQUE LIMIT switch into its UP position (10 inch model).

Feel the greater amount of tape tension developed during acceleration of the tape in a new mode. Also note that the speed change is quicker.

The 10 inch transport has a single torque limit switch. In UP position (for normal tape and 10 inch reels) the maximum torque is 49.5 inch ounces. In DOWN position (for plastic reels and alignment tapes only) the maximum torque is 22.5 inch ounces.

The 14 inch transport has three torque limit switches. The HI switch is for use with 14 inch reels ONLY and has a maximum torque of 72 inch ounces. The MED switch is for use with normal tape and 10 inch reels and has a maximum torque of 49.5 inch ounces. The LO switch is for use with plastic reels and alignment tapes and has a maximum torque of 22.5 inch ounces.

The EXT position of the REFERENCE switch is provided for synchronizing this machine with some other piece of equipment. The SERVO plug on the back of the transport chassis provides connections to this circuit. There are two methods of controlling the speed of the machine through this channel:

1. A signal of $\pm 5\text{vdc}$ will vary the frequency of the internal VCO. When switched to EXT, this signal voltage can control the speed of the machine.
2. A 19.2 KHz signal can be applied to the external reference. The frequency of the external signal then controls the speed of the machine.

The MCI AutoLock is a separate unit which synchronizes a slave machine to a master machine using the SMPTE, EBU, or NTSC (drop frame) digital time code. The slave machine reference switch is set to the SLAVE position. The master machine reference switch is turned to FIX. Synchronization is achieved by comparing synchronizing detect pulses of the slave to the master machine and altering the speed of the slave. The master machine speed is set by fixed 19.2 KHz (and by LO, MED, or HI speed switch) and controls the slave machine speed which receives speed information from the AutoLock.

2.2.3 RTZ III Locator Controls

When the transport locates to any desired position, the tape should quickly accelerate to the fast forward or rewind speed and smoothly decelerate to a stop or to play speed. Note that negative tape positions are indicated with a flashing point between the minutes and seconds. Negative positions cannot be stored in memory.

Load a roll of tape. Press CLR.

Display indicates zero minutes and seconds.

Enter tape positions into memories 1 and 2.

Example — Enter 15 minutes, 29 seconds into Memory 1.
Press and hold SET.

Press 1 once. Press 2 five times. Press 3 twice.
Press 4 nine times.

Digit increments each time button is pressed.
Display indicates 15:29.

Release SET.

Press STO, then Press 1.
Position 15:29 is entered into memory 1.

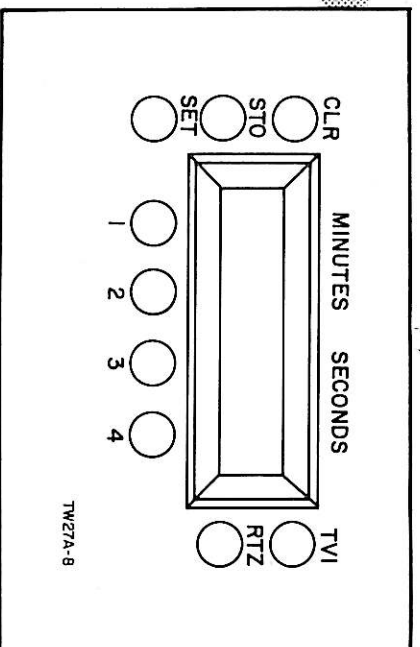

Figure 2-11 RTZ III Display

Repeat above procedure to enter any position into memory 2.

Display indicates desired position entered into memory 2.

Press CLR. Press 1.

Display indicates 0:00. Transport locates to 15:29 and stops.

Press 2, then press PLAY.

Transport locates to position entered in memory 2 and switches to play mode.

Press and hold TVI switch.

Display indicates tape velocity selected by SPEED switch.

Release TVI.

Press STO, then press 3.

Present tape position is entered into memory 3.

Press RTZ.

Transport locates to position where zero was set and stops.

Press 3.

Transport locates to position where STO and 3 were pressed while in play mode.

Repeat above step for memory 4.

Press FWD. Allow tape to run out from supply reel.

Note position indicated on display, then clear display with CLR.

Display counts up until supply reel runs out.

Re-thread tape onto supply reel. Enter position noted above into display with SET and 1, 2, 3, 4 switches.

Press RTZ.

Transport rewinds to beginning of tape and stops before un-spooling from take-up reel.

2.2.4. Audio Controls

NOTE:

Each track has its own electronics panel (a 2 track machine has 2 electronic panels, a 4 track machine has 4 electronic panels, etc.) The controls for each track are identical.

For the following examples it will be necessary to provide a signal input (an audio generator is preferred), and an output monitoring system.

PREPARATION:

Load a roll of degaussed tape.

Put the two small toggle switches on the electronics panel(s) into CAL position (down).

Put the BIAS switch into its OUT position (not reading bias).

Press the INPUT switch.

Press the READY switch.

Put a 500 Hz signal into line input of the channel(s) under test.

If necessary adjust the REC level until the meter reads 0 VU.

Press the PLAY and RECORD buttons on the transport.
Record several minutes of 500 Hz tone.

Press the RTZ button on the transport. Change the input signal to 700 Hz.

If necessary, adjust the REC level until the meter reads 0 VU.

NOTE:

We now have 500 Hz recorded on the tape, and 700 Hz applied to the input. We can easily tell, by listening, whether we are playing back the previously recorded 500 Hz or the 700 Hz from the input.

Press STOP.

Press the SAFE switch(es) on the audio electronics panel(s).

Press the REPRO switch(es).

There is NO output on the VU meter or on the Line Output.

Press the INPUT switch(es).

The output shown on the VU meter and heard on Line Output is 700 Hz (the input signal).

Press the CUE switch(es).

There is NO output on the VU meter or on the Line Output.

Press the PLAY switch on the transport.

Press the REPRO switch.

The output shown on the VU meter and heard on the Line Output is 500 Hz. (The previously recorded signal).

Press the INPUT switch(es).

The output shown on the VU meter and heard on the Line Output is 700 Hz. (The input signal).

Press the CUE switch(es).

The output shown on the VU meter and heard on the Line Output is 500 Hz. (The record head is monitoring the previously recorded signal).

Press the READY switch(es) on the audio electronics panel(s).
The amber LED(s) turn ON.

The amber LED(s) turn ON.

Press the RECORD switch on the transport.
The red LED(s) turn ON.

Press the REPRO switch(es).

The output shown on the VU meter and heard on the Line Output is 700 Hz. (The reproduce head is monitoring the signal immediately after it is recorded).

Press the INPUT switch(es).

The output shown on the VU meter and heard on the Line Output is 700 Hz. (The input signal

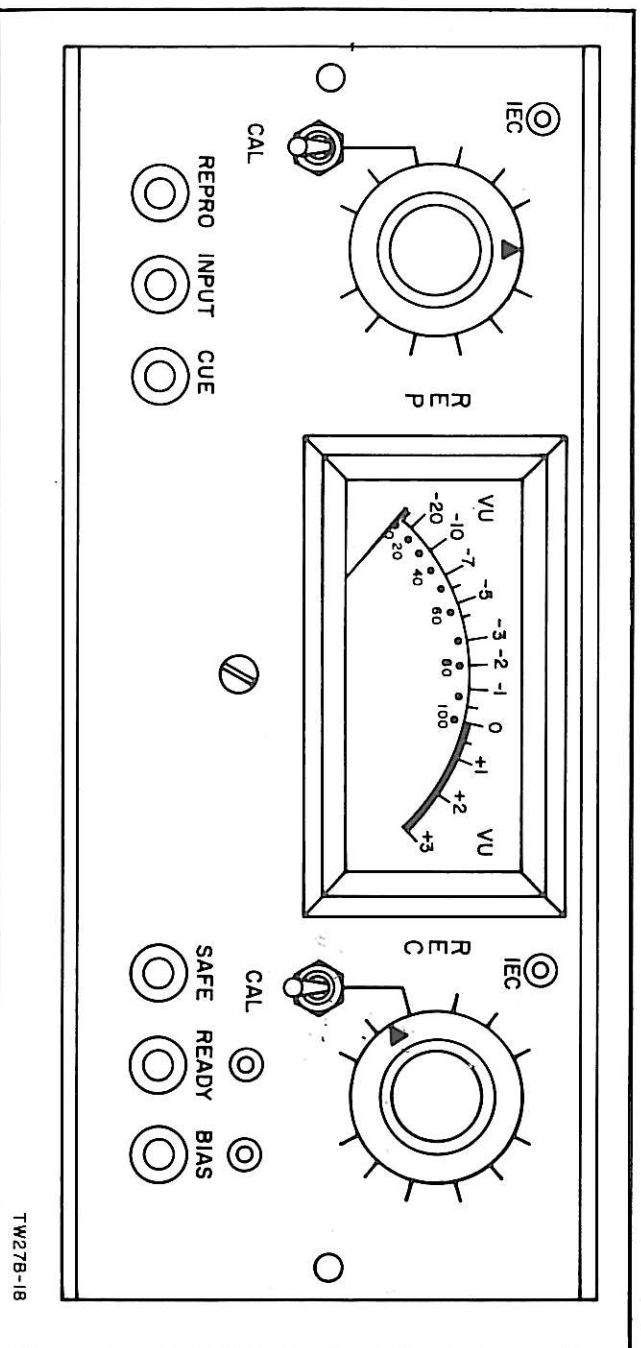

Figure 2-12 Audio Controls

as it is recorded).

Press the CUE switch(es).

The output shown on the VU meter and heard on the Line Output is 700 Hz.

CUE mode switches automatically in the following way:

In Play mode it monitors the record head.
In Record mode it monitors the Line input.

Change the REC CAL toggle switch(es) to their UP position. Press the REPRO switch(es).

Slowly vary the setting(s) of the REC potentiometer(s).

The level shown on the VU meter and heard on the Line Output varies in step with the record potentiometer.

2

Set the REC potentiometer(s) so that the meter(s) read -7dB.

The Line Output has a reduced level.

Press the BIAS button(s). (DOWN position).

The VU meter reads the bias level (approximately 0 VU). 700 Hz tone is still heard on the Line Output.

Press the BIAS button(s) a second time, (UP position).

VU meter reading returns to -7dB (700 Hz Record level).

Return the REC CAL toggle switch(es) to their CAL (down) position.

VU meter reading returns to 0 VU. 700 Hz tone from the Line Output returns to full output level.

Change the REPRO CAL toggle switch(es) to their UP position. Slowly vary the setting(s) of the REPRO potentiometer(s).

The level shown on the VU meter and heard on the Line Output varies in step with the reproduce potentiometer. (The 700 Hz tone is

being recorded at standard level — the reproduce gain is being varied).

Leave the REPRO potentiometer so that the meter(s) read -5dB.

Return the REPRO CAL toggle switch(es) to their CAL (down) position.

The output level shown by the VU meter and by the Line Output has returned to standard (0 VU).

Vary the setting of the REPRO potentiometer(s) and the REC potentiometer(s).

Output level does NOT change. Reproduce CAL switch and record CAL switch remove the potentiometers from the circuits.

Unlatch the electronics panel(s) and pull out so that the plug-in cards are visible.

Press the red button(s) at the front of the Reproduce Card(s) (Down position).

The green IEC LED(s) light above the reproduce potentiometer(s). (Equalization circuits on the Reproduce Cards have been switched to IEC standards).

Press the red button(s) a second time (UP position).

The green IEC LED(s) to OFF. (Equalization circuits on the Reproduce Cards have now been switched to NAB standards).

Press the red button(s) at the front of the Record Card(s) (down position).

The green IEC LED(s) light above the record potentiometer(s). (Equalization circuits on the Record Cards have been switched to IEC standards).

Press the red button(s) a second time. (UP position).

The green IEC LED(s) go OFF. (Equalization circuits on the Record Cards have now been switched to NAB standards).

Figure 3-1
Transport Simplified
Block Diagram

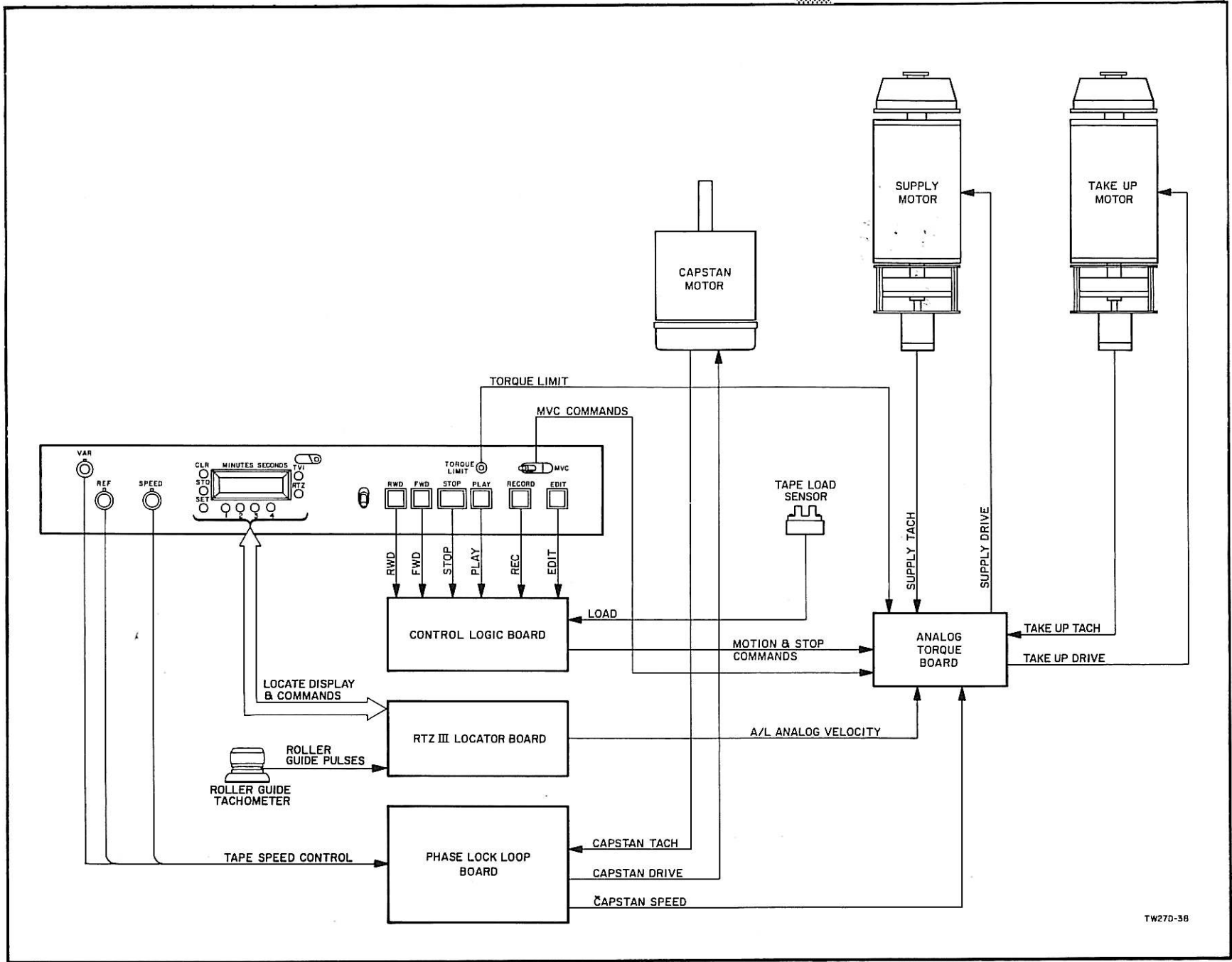

SECTION 3

TAPE TRANSPORT

3.1 General Description

Functionally, the tape transport consists of four major systems: the control logic system, the capstan servo system, the tape tension servo system, and the autolocator system. Figure 3-1 illustrates the transport's four systems. The control logic, capstan servo, and tape tension servo systems are covered in this section. The autolocator is covered in Section 4 of this manual.

The control logic system generates commands which control the operation of tape transport. Inputs to the Control Logic Board come from the motion control switches and tape load sensor. Outputs from the Control Logic Board operate the indicator lights, reel motor brakes, pinch roller, and tape lifters. Motion and stop commands control the operating mode of the tape tension system.

The capstan servo system moves the tape past the heads at a constant velocity during play and record modes. Reference and speed switches select the reference frequency for the phase locked loop. The Phase Locked Loop Board, capstan motor, and capstan tachometer form the servo loop, which locks the capstan motor's speed to the selected reference.

The tape tension servo system keeps a constant tension on the tape during the stop, play, and record modes and reels the tape in the rewind and fast forward modes. Reel motor motion is servo controlled by the Analog Torque Board. Commands from the control logic select the servo reference which determines the speed and direc-

tion of the motors. The reel motors can also be controlled by signals from the MVC and the autolocator.

3.2 Control Logic

The control logic system consists of the Control Logic Board, the Interface/Lamp Driver Board, and three solenoid Driver Boards. Drivers on the Interface/Lamp Driver Board operate the motion control lights and the record relays. This board also buffers the autolocate and MVC commands. The Solenoid Driver Boards contain amplifiers which operate the reel motor brake, pinch roller and tape lifter solenoids in response to TTL signals from the Control Logic Board.

The Control Logic Board contains combinational logic circuits whose outputs control all the functions of the transport. Portions of the schematics have been redrawn to help you follow the signals through the logic. These drawings show the logic levels present for the mode indicated. If measuring these levels, remember, that outputs of the cross coupled latches remain constant until switched, and the outputs of the switches and pulse networks are momentary.

Figure 3-2 shows the logic involved in the stop mode. The number inside each gate is the chip's IC number in the schematic diagram. Logic levels in the figure indicate the stop mode with tape in the tape sensor slot.

Figure 3-3 shows the logic involved in the play and the play/record modes.

Figure 3-4 and 3-5 have the logic for the fast forward and rewind modes.

Edit is initiated by pressing the EDIT switch with tape in the tape sensor.

Figure 3-6 shows the logic for the edit modes. Some of the circuits shown are located on the mother board. There are two edit modes, Edit and Edit'. Edit is initiated by pressing the EDIT switch after removing the tape from the tape sensor.

Figure 3-7 shows the logic involved in the tape deck manual velocity control (DMVC) and remote manual velocity control (RMVC) modes and in moving the tape lifters.

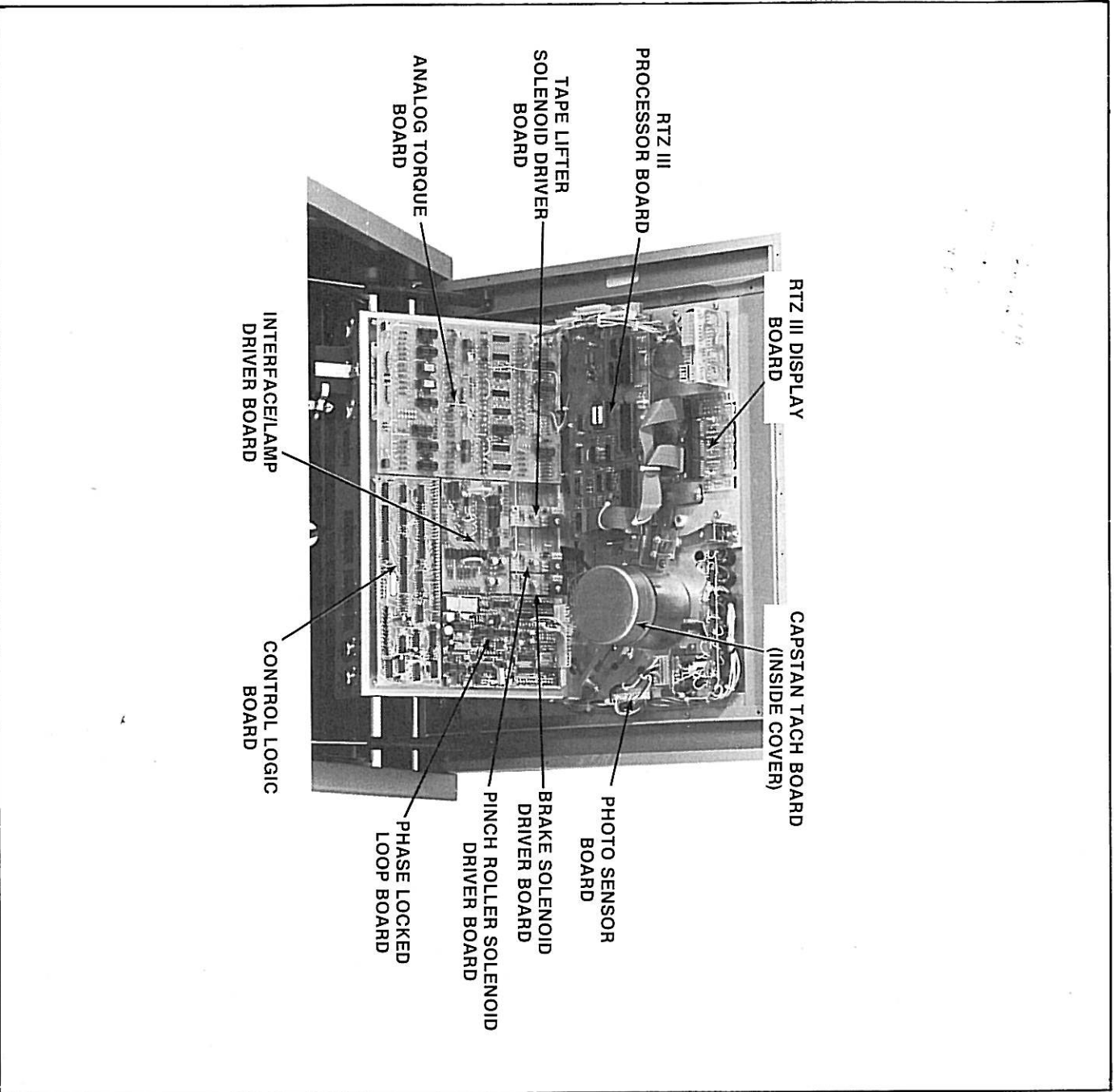

Transport Circuit Board Locations

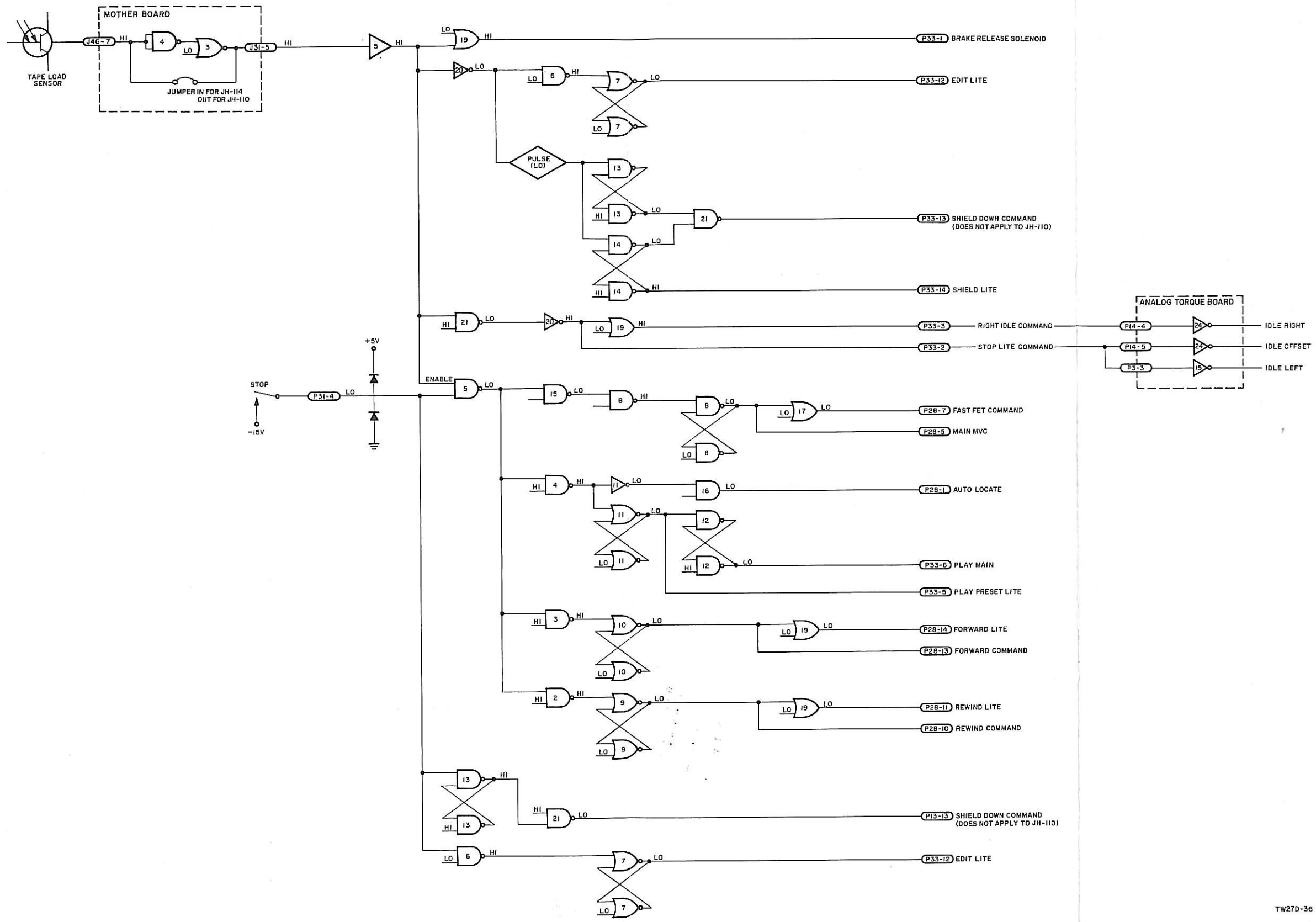

TW27D-36

Figure 3-2
Tape Load and Stop
Commands

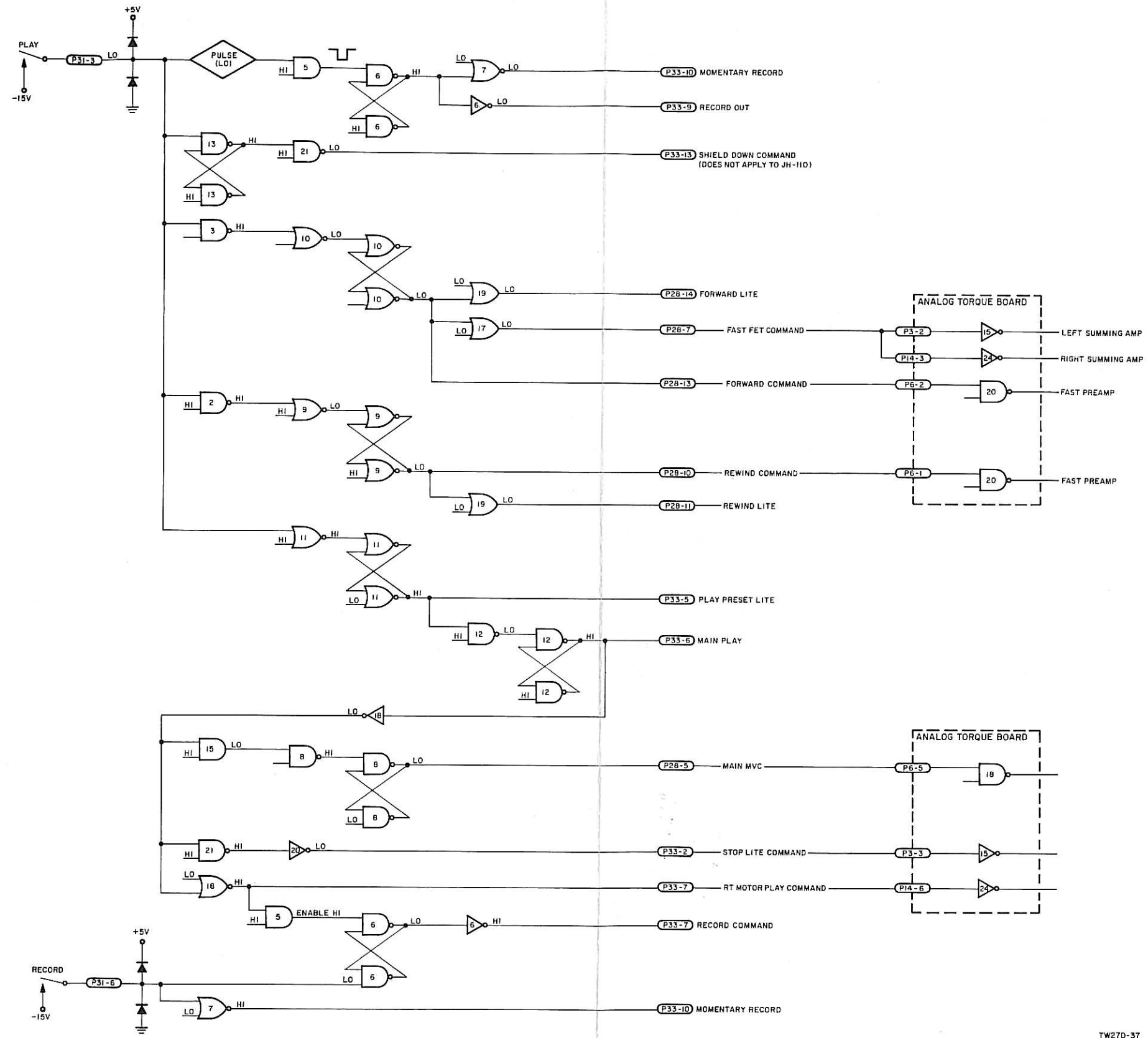

Figure 3-3
Play and Record
Commands

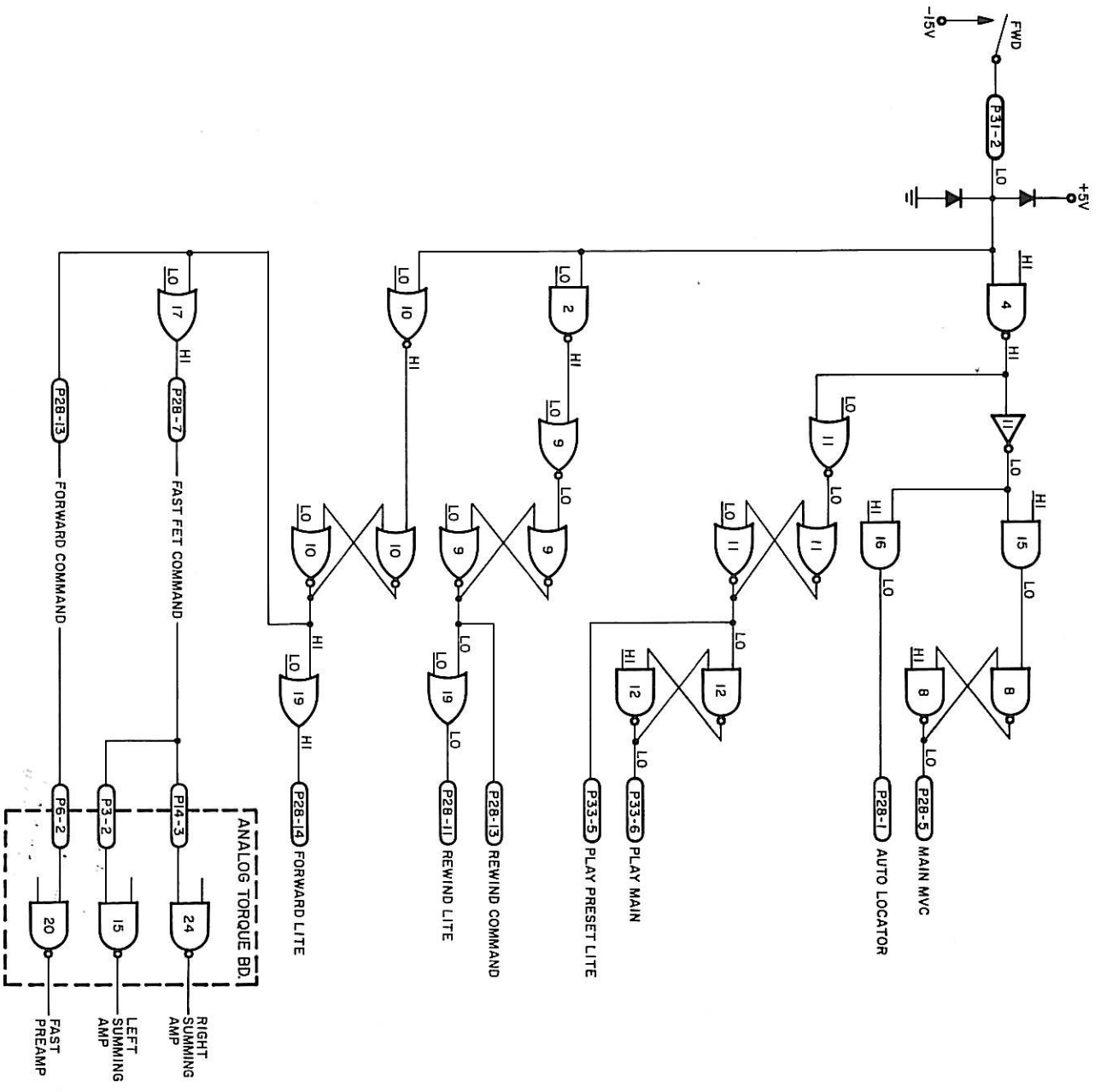

Figure 3-4
Fast Forward
Commands

TW27C-29

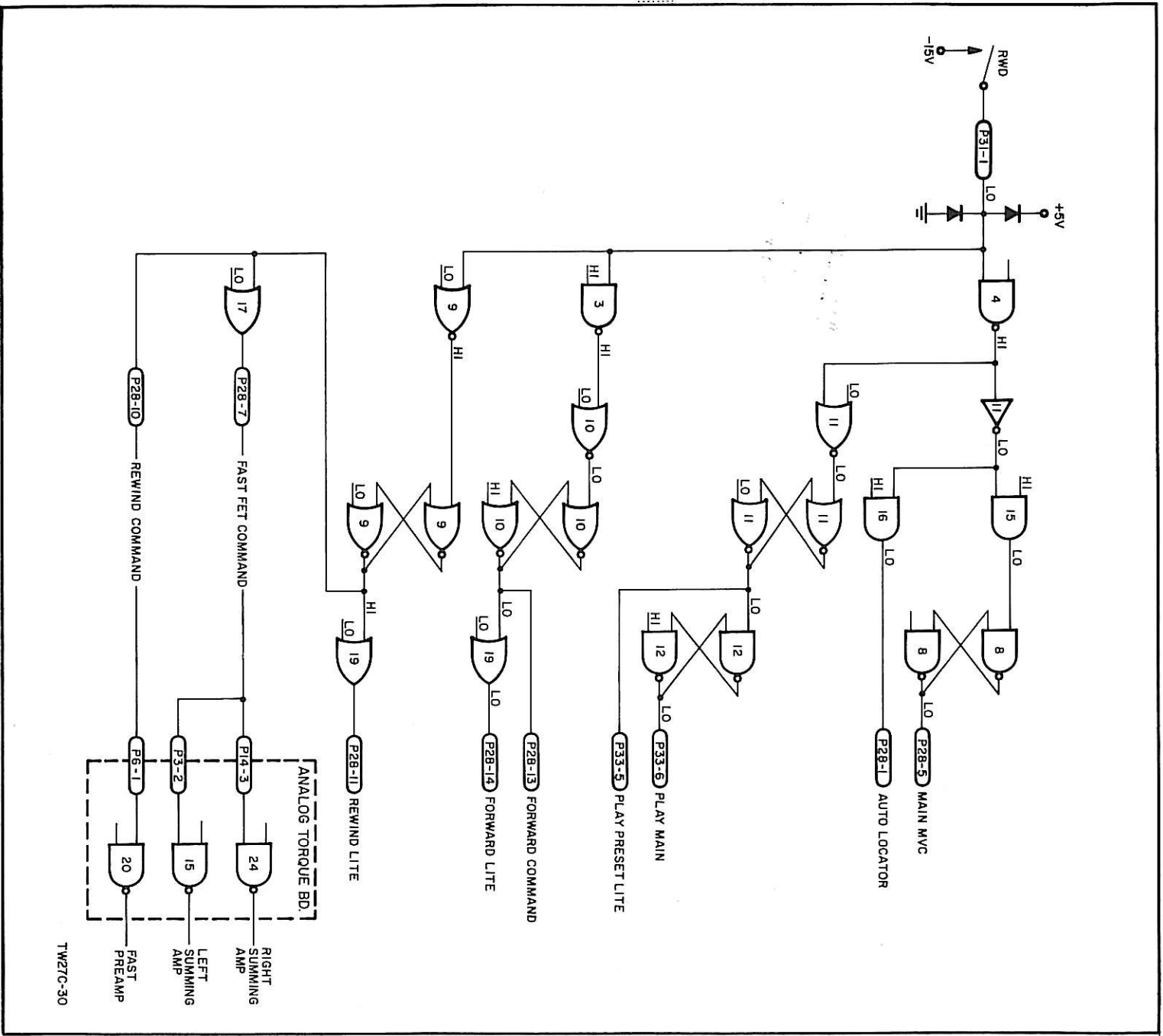
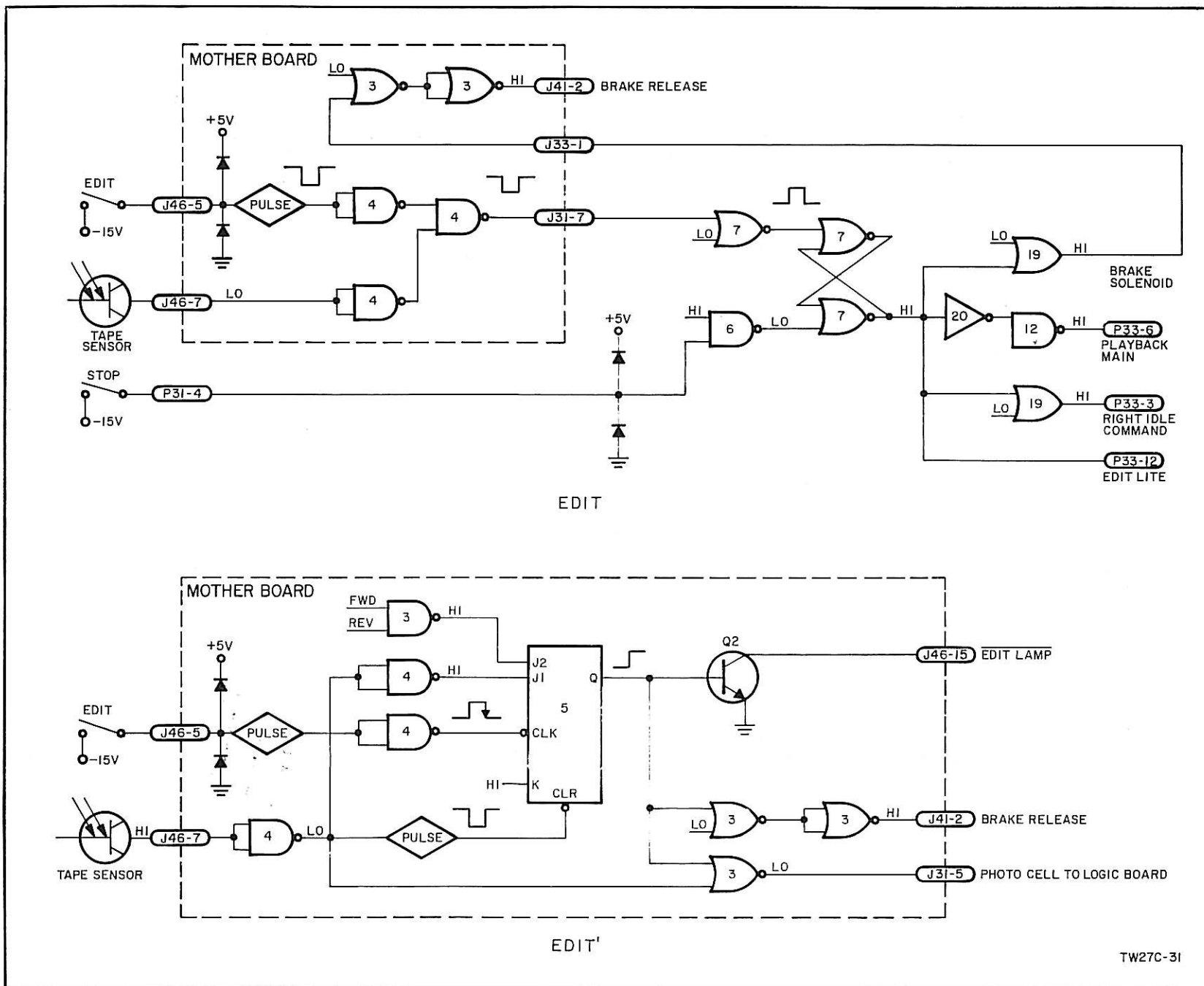

Figure 3-5
Rewind Command

TWZTC-30

Figure 3-6
 Edit and Edit'
 Commands



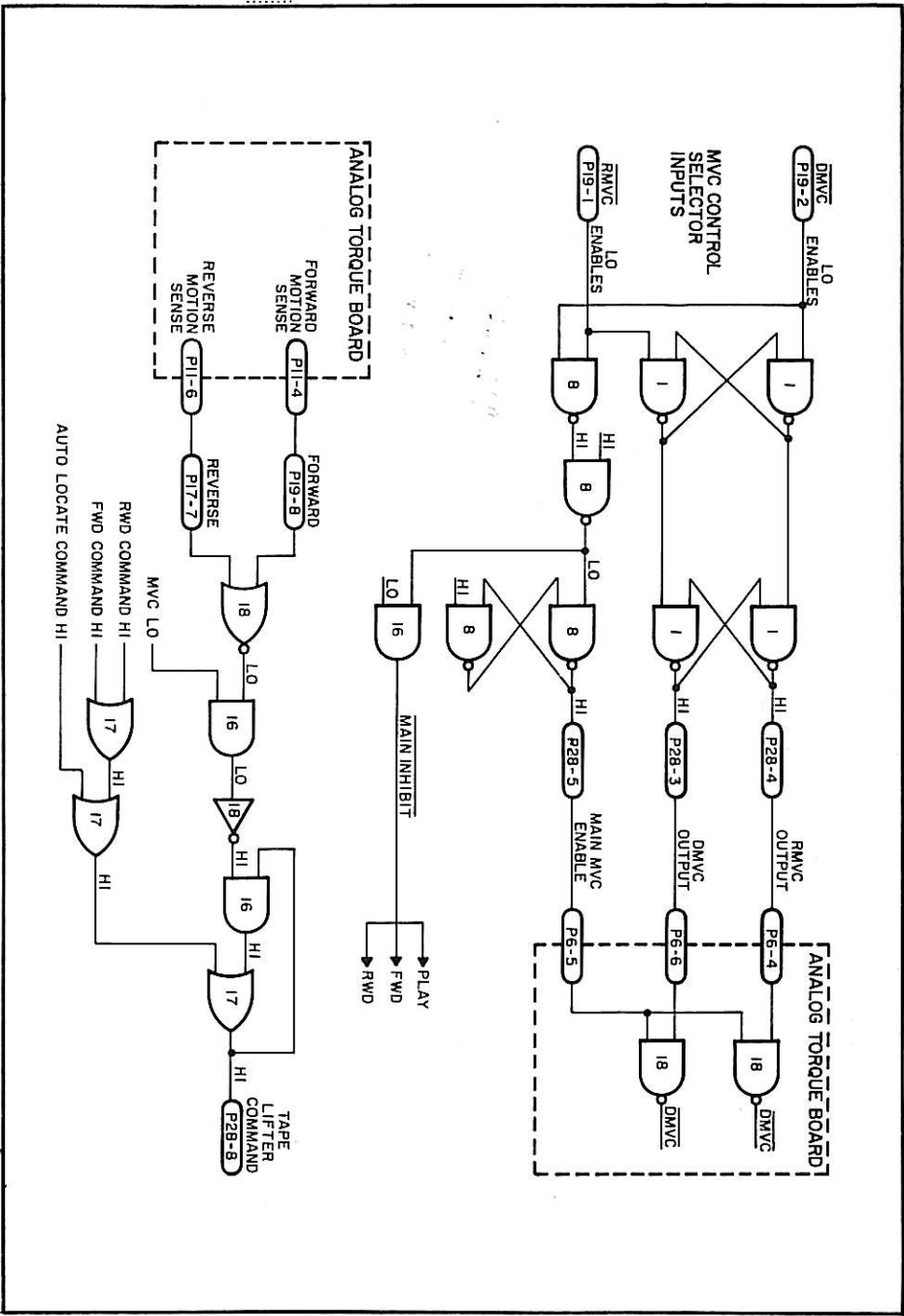

Figure 3-7
MVC and Tape Lifter
Commands

3.3 Capstan Servo System

3.3.1 Phase Locked Loop

Figure 3-8 is a block diagram of the capstan servo system showing the phase locked loop, reference select logic, and the capstan dc motor. Whenever the play mode is initiated, the capstan motor accelerates to the selected speed. When the motor speed approaches the reference speed, the servo locks. Once lock is established the capstan turns at a constant speed.

The rectangular wave output from the phase comparator is averaged by an active filter. The resulting dc level is then amplified and used to drive the capstan motor.

The capstan's speed is measured by a slotted disk and photo sensors mounted to the bottom of the capstan motor. This tachometer produces 500 pulses per revolution. The frequency of the pulse train is directly related to the motor speed. On the Capstan Tach Board, the tachometer output frequency is doubled and applied to a buffer on the Phase Locked Loop Board. This buffer clocks the one shot. At 15 ips this frequency is 9.6 kHz and can be measured at test point 1. The one shots fix the pulse widths of the tachometer and reference waveforms to 5µs as required by the phase comparator.

The phase comparator produces an output waveform whose duty cycle is proportional to the phase difference between the reference pulses

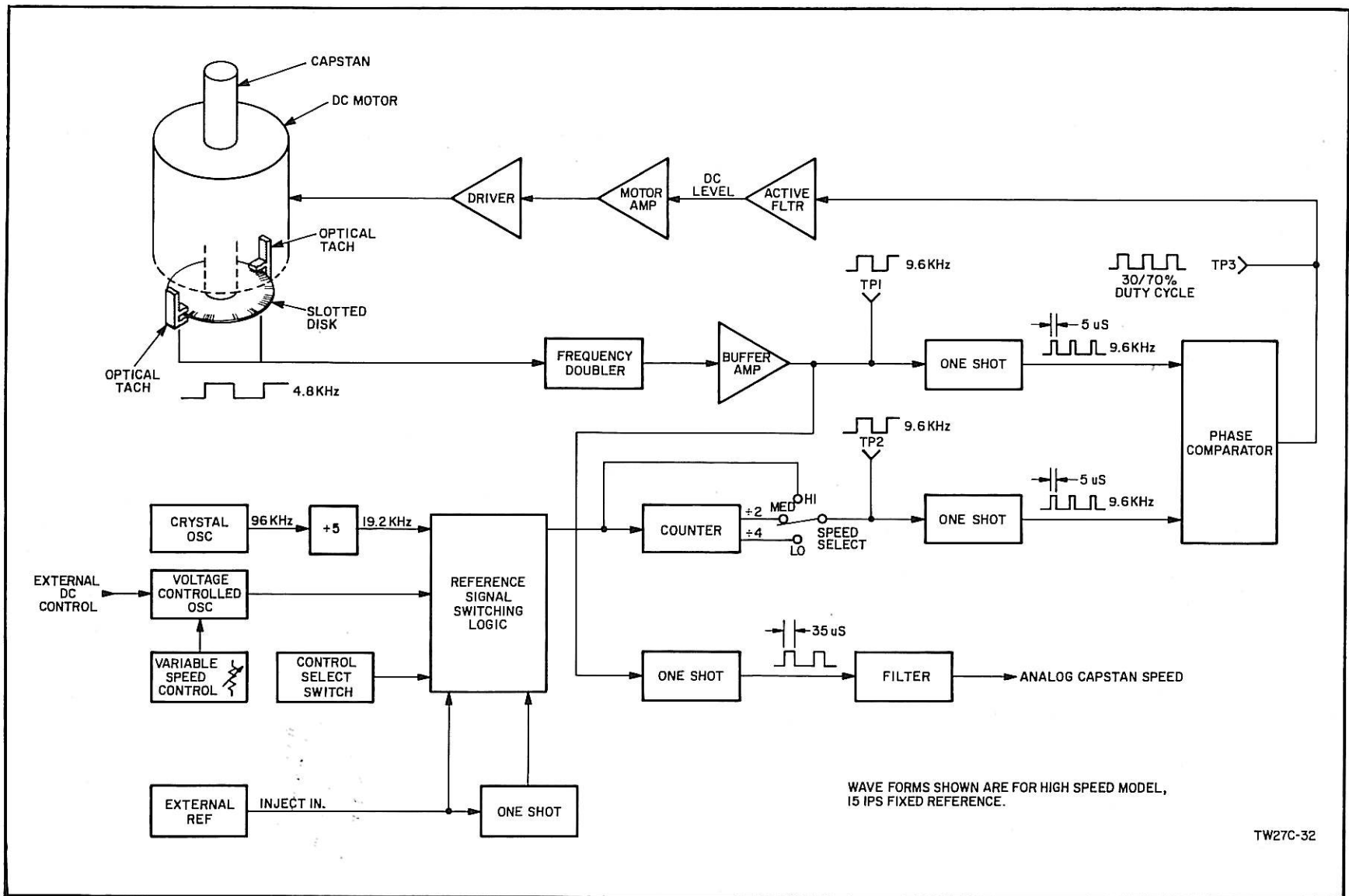

Figure 3-8
Capstan Servo Block Diagram



and the tachometer pulses. Specifically, the pulse width of the phase comparator output is equal to the time difference between the rising edge of the reference pulse and the falling edge of the tachometer pulse. Prior to achieving lock the output of the phase comparator is latched high. After obtaining lock, the output has approximately a 30% duty cycle. If the tachometer pulses begin to lag behind the reference pulses, the duty cycle increases, speeding up the motor. As the motor speeds up, the phase difference between the two pulse trains decreases, decreasing the duty cycle of the phase comparator output and slowing the motor.

3.3.2 Reference Frequency

The reference frequency for the phase locked loop comes from one of three sources: a crystal oscillator, a VCO, or some external source. Figures 3-9, 10, 11, and 12 detail the reference selection circuit.

When the speed reference switch is in the FIX

position, a 96 kHz crystal oscillator provides the reference. The crystal frequency is divided down to 19.2 kHz and applied to the speed select circuit. The speed select switch and a binary counter choose the frequency reference for high, medium, and low speed operation.

When the speed reference switch is in the VAR position, the VCO supplies the input frequency to the speed select circuit. The center frequency of the VCO is 19.2 kHz. The output frequency can be varied by $\pm 20\%$ with a ± 5 volt input. Either the variable speed control potentiometer (in VAR) or an externally supplied dc level (in EXT) provide the reference input to the VCO.

When the speed reference switch is in the EXT position an external frequency input is selected as the speed reference for the phase locked loop. For standard speed operation this signal should be 19.2 kHz. If no external frequency is present and the reference switch is in the EXT position, the reference circuit chooses the internal VCO as the reference input.

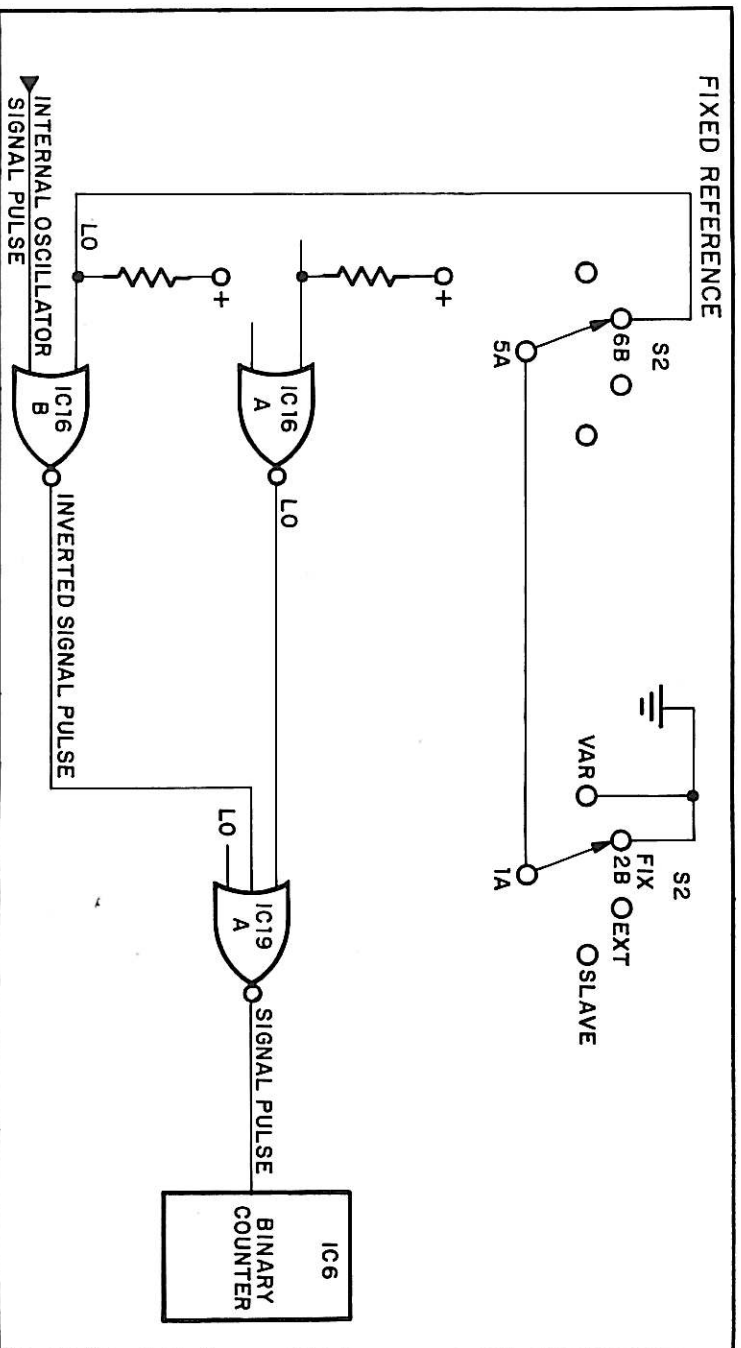

Figure 3-9
Internal Reference Circuit,
Fixed

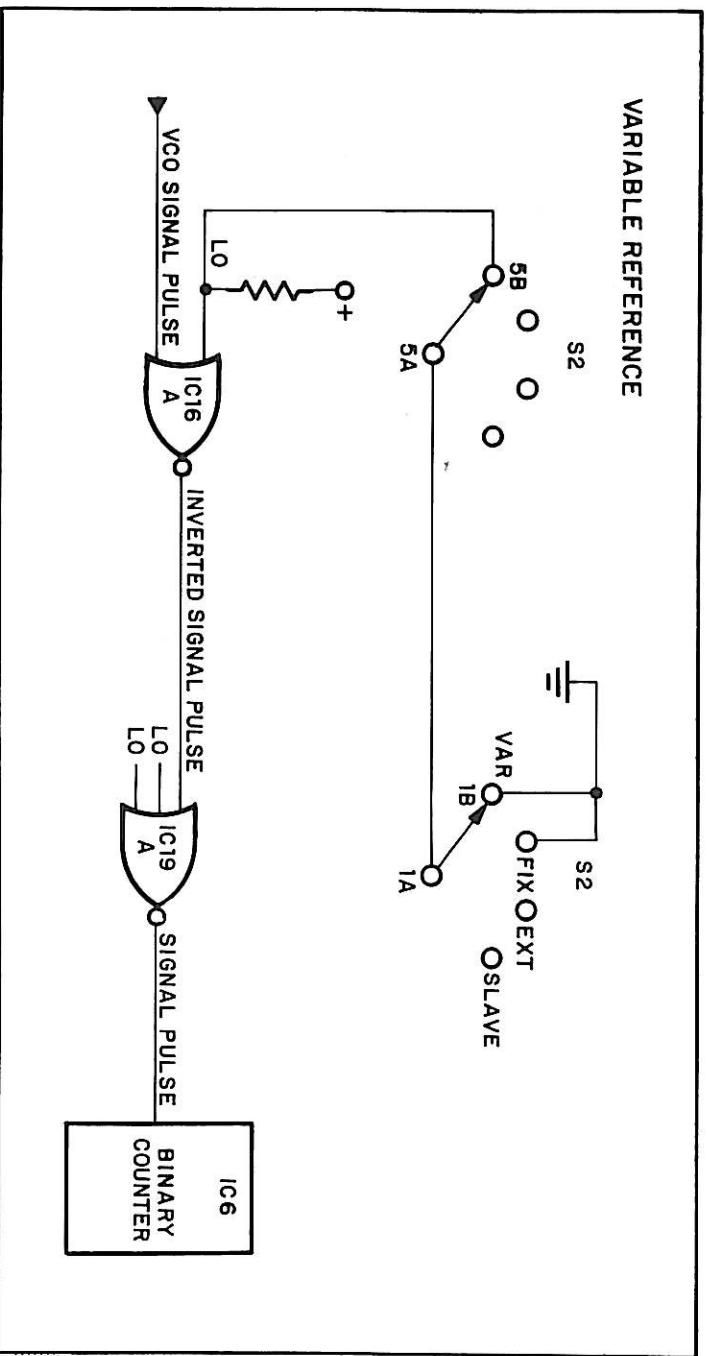

Figure 3-10
Internal Reference Circuit,
Variable

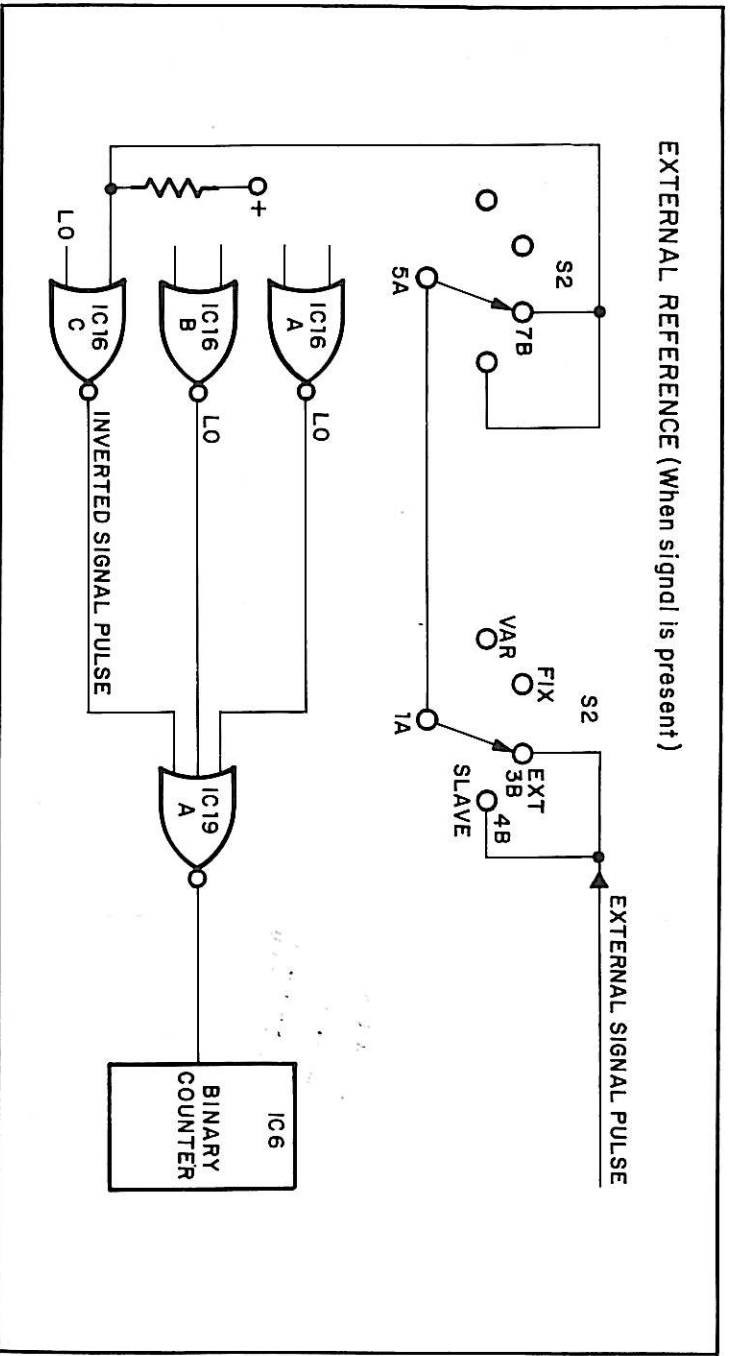

Figure 3-11
External Reference Circuit,
With Signal

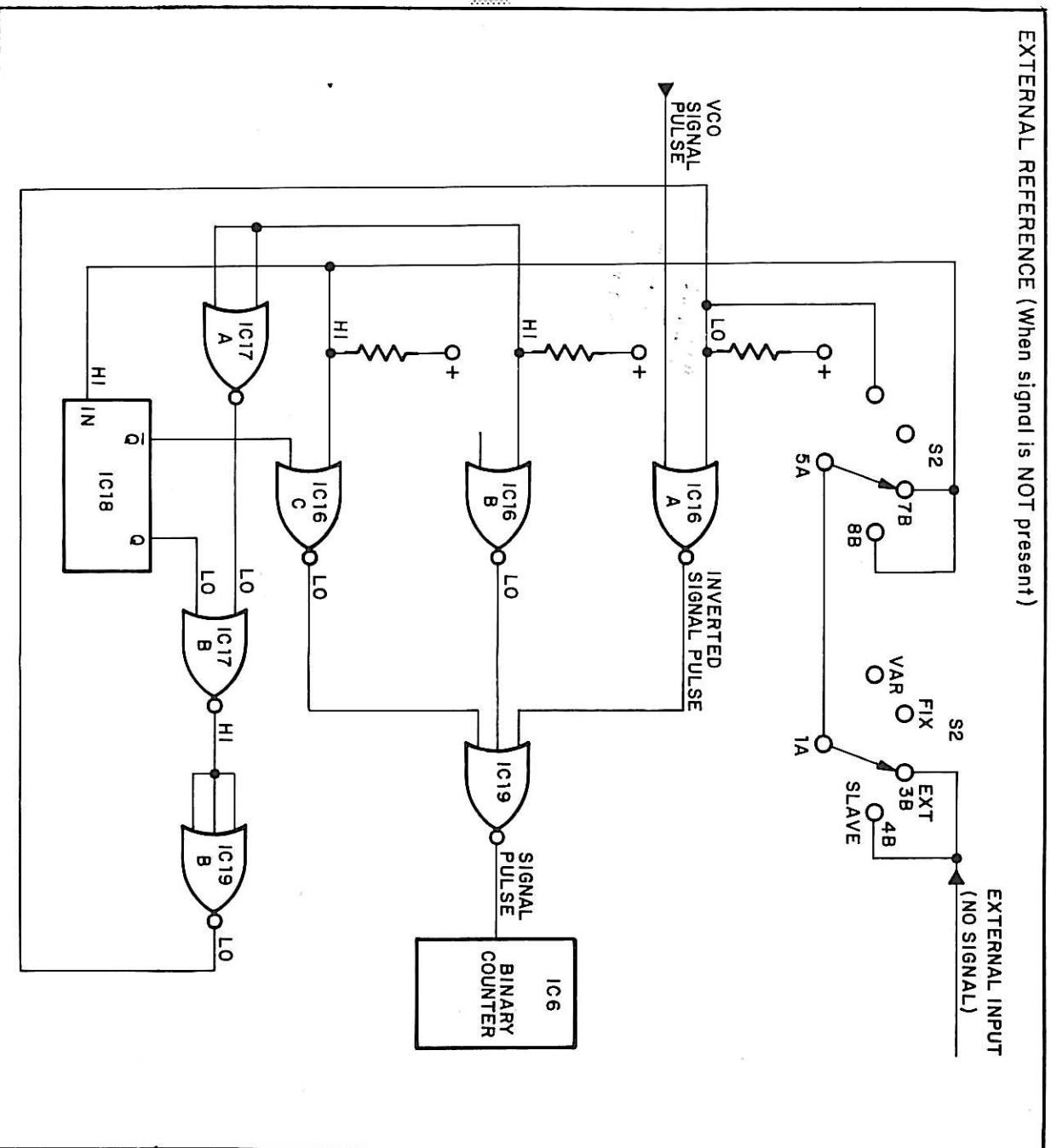

Figure 3-12
External Reference Circuit,
Without Signal

3.4 Tape Tension Servo System

Figure 3-13 is a block diagram of the tape tension servo system. All the circuits represented in the diagram are located on the analog torque board, except the phase locked loop and the motor drivers. The motor drivers for the reel motors are located in the power supply.

A positive signal applied to the reel motor drivers allows current to flow through the motors. This

current produces a torque which accelerates the motor. The torque is always applied in the direction to pull the tape. That is, the supply reel is always driven in a clockwise direction and the take up reel is always driven in a counter-clockwise direction.

The tape tension servos are always active, whenever there is tape in the tape load sensor. Reel motor speed is continually adjusted to maintain a constant tension on the tape in all modes.

Figure 3-13
Tape Tension System
Block Diagram

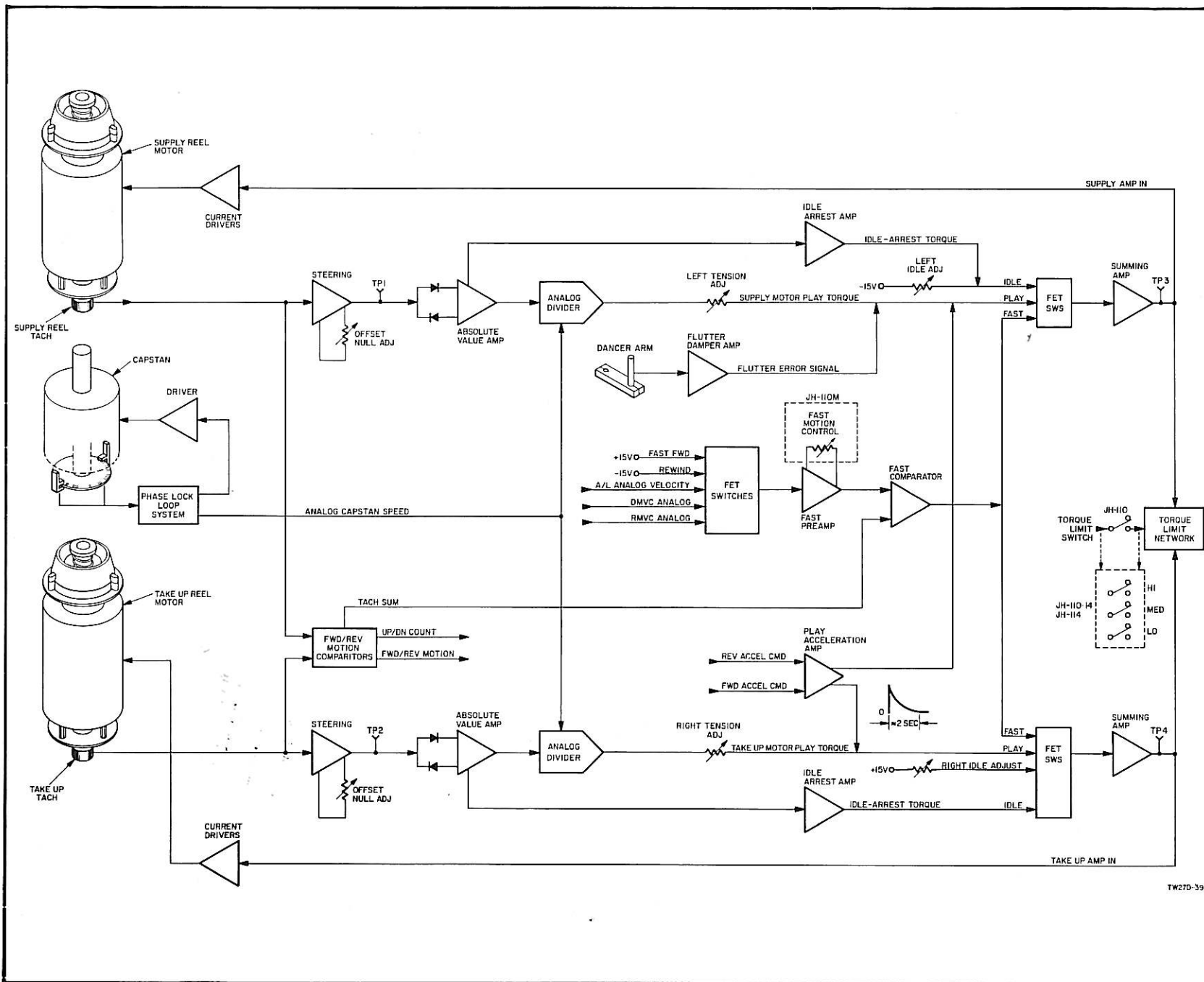

TW270-39

Commands from the control logic, through FET switches, select the servo loop involved in each mode. There are three tension servo loops: the idle servo loop for the stop mode, the play servo loop for the play and record modes, and the fast servo loop for the fast forward, rewind, autolocator, and MVC modes.

3.4.1 Idle Servo Loops

There are two idle servo loops, one for each reel motor. In the stop mode, they drive both reel motors in opposite directions to apply the required tension on the tape. With no tape reels mounted on the motors and a card in the tape sensor slot, you can see the reel motors turning in opposite directions, completing one revolution every three seconds.

The torque applied to the motors is set by the idle adjust potentiometers. The idle adjust level is summed with the dc output of the tachometers to resist any motion which tends to alter the tension on the tape. This provides a dynamic braking force which decelerates the tape when the STOP button is pressed, and prevents the reels from moving once they stop. In stop mode, the reels should only turn to take up slack in the tape path to restore the proper tension.

3.4.2 Play Servo Loops

There are two separate play servo loops, one for each reel motor. During play mode, the servos apply the torque required to keep the tape moving at a constant speed under constant tension. When properly adjusted, the reel motors actually transport the tape. The capstan motor only meters the speed of the tape, it does no work in pulling the tape across the heads.

The torque required to keep a constant tension on the tape depends on the amount of tape on each reel. Since the amount of tape on a reel changes continuously during play and record, the torque must be continuously adjusted. Divider circuits in the servo loops calculate the adjustments necessary to maintain the proper tension.

The tension applied to the tape is equal to the motor's torque divided by the effective radius, which is the distance between the center of the hub and the point at which the tape leaves the reel. This means that for any given torque, the ten-

sion decreases as the tape radius increases. Therefore, in order to keep the tape tension constant, the torque must increase as the radius increases. More torque is required for a full reel (large radius) than for an empty one (small radius).

The radius of the roll of tape is proportional to the speed of the tape divided by the speed of the reel motor. A full reel, which requires more torque because of its larger radius, turns slower than an empty reel, which requires less torque because of its smaller radius. The reel motor tachometer supplies a dc level indication of the reel motor speed. The capstan tachometer supplies a dc level indication of the tape speed. Analog dividers in the play servo loops divide the tape speed by the reel motor speed producing a torque signal proportional to the radius of the roll of tape.

In play or record mode, as the take up reel fills with tape, the torque is proportionally increased to pull the tape with the proper tension. The opposite happens to the supply reel whose radius decreases. It requires less torque to decelerate the reel to apply the proper holdback tension.

Some versions of the JH-110B use a mechanical (air dashpot) dancer arm flutter damper; others use an electronic flutter damper. The dashpot type is not electrically connected to the tape tension servo system. It operates as a shock absorber to smooth out variations in the tape's movement.

The electronic flutter damper produces an error signal that is summed into the supply motor play servo loop. A permanent magnet, connected to the dancer arm, is positioned directly over an inductor coil. Whenever the magnet moves over the coil it induces a current proportional to its velocity. This velocity signal increases or decreases the torque applied to the supply reel motor during play mode.

3.4.3 Fast Servo Loop

There is one feedback loop involved in the fast modes. The control logic selects the fast servo loop FETs in the fast forward and rewind modes, and when the transport is under autolocator or MVC control. Torque, applied by the servo, drives the tape at a constant speed selected by the FWD or RWD switches or by the autolocator or MVC analog velocity voltages.

The fast feedback loop consists of summation of the two reel motor tachometer signals. The fast loop servos when the combined speed of both reel motors reaches the control velocity at the fast comparator. In the fast forward and rewind modes this is approximately 300 inches per second. From that point, the reel motors are accelerated only to maintain the speed selected by the FET switches. The combined tachometer signals also produce

direction information for the autolocator's position display.

Torque limiting circuitry clamps the output of the fast comparator to limit the maximum torque applied to the motor. The maximum torque is controlled by the torque limit switch(es) mounted on the transport deck.

PCA2500-0027
CONTROL LOGIC

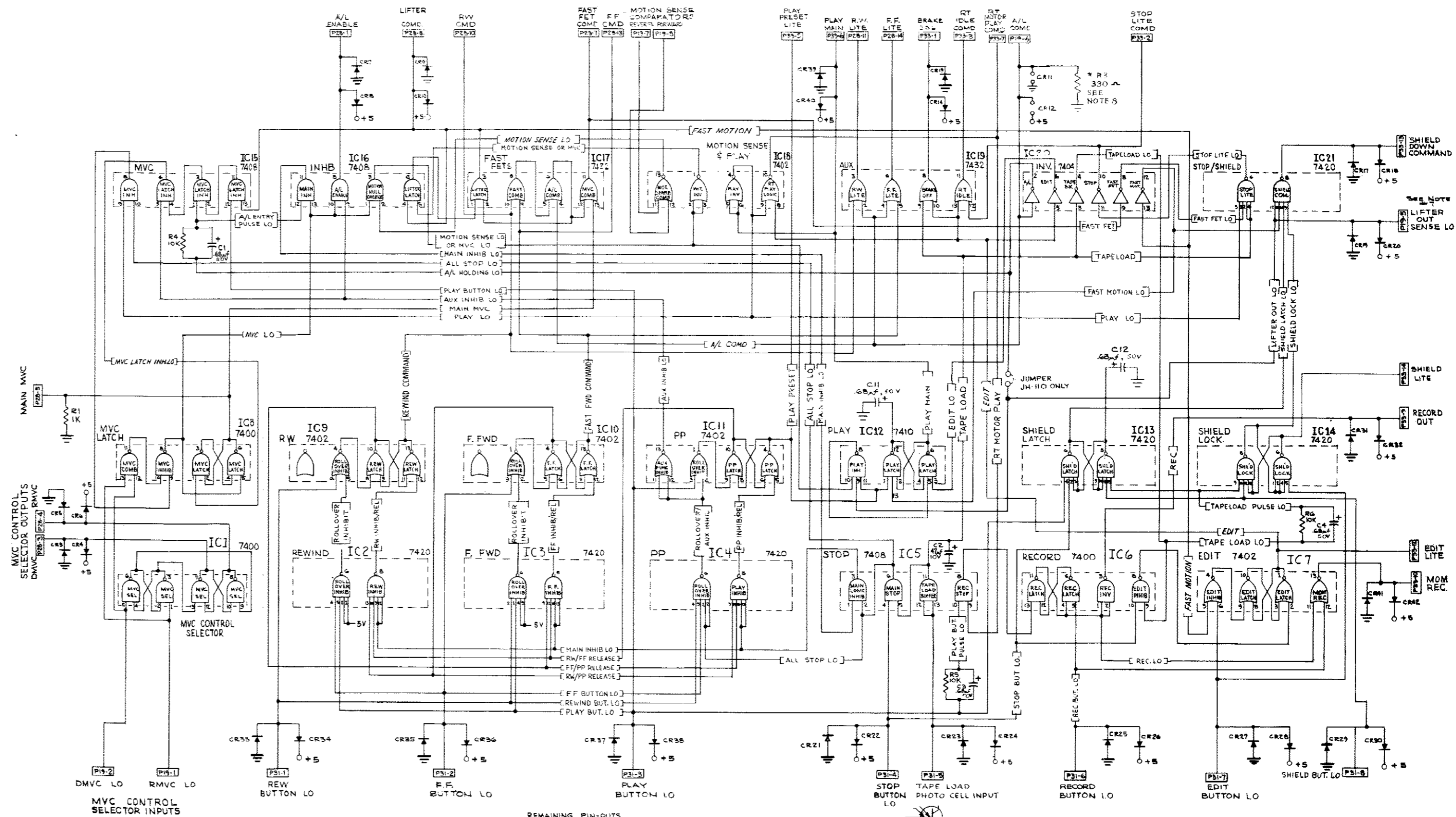
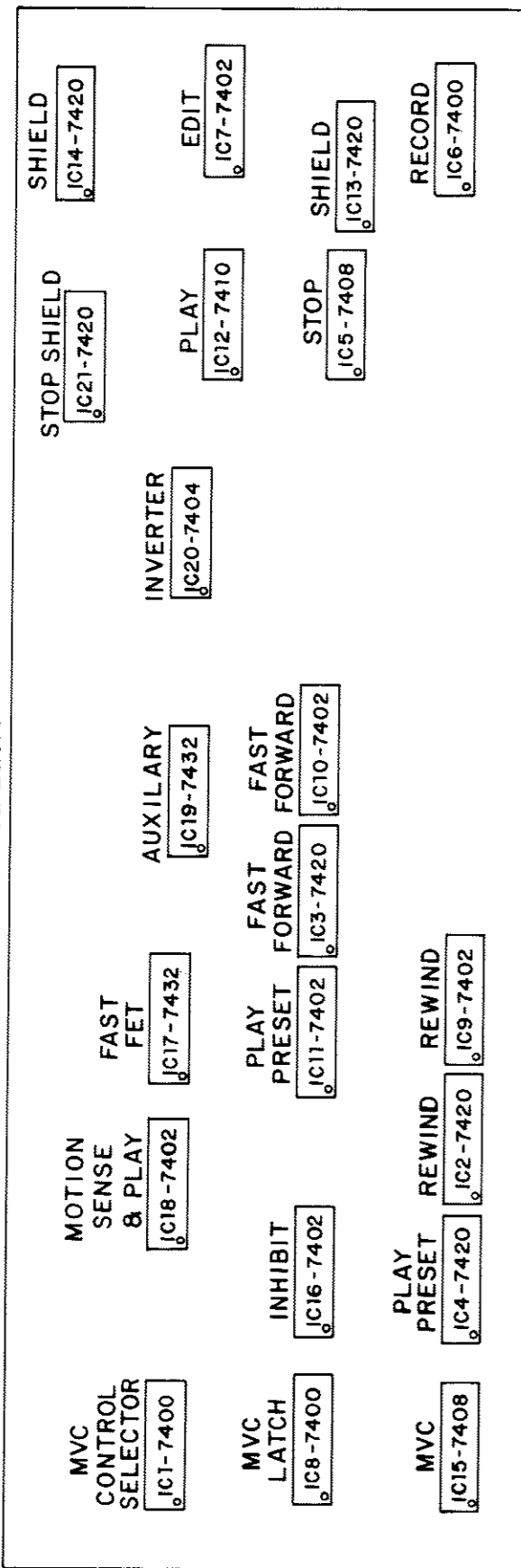

- REMAINING PIN-OUTS**
 +5V GND SPARE
 P19-3 P22-2 P19-4
 P20-6 P19-9
 P20-9 P20-10
 P20-12 P31-9
 P32-2 P31-10
 P32-5 P31-11
 P33-11
- NOTES:**
 1) ALL DIODES ARE IN4004.
 2) ALL RESISTORS ARE 1/2 W, 5% TOL.
 3) ALL CAPACITORS ARE IN MICROFARADS/VOLTS.
 4) ALL IC'S RECEIVE +5V AT PIN 14 & GND AT PIN 7.
 5) USE DECOUPLING CAPS (0.1µF) AS NOTED ON ASSY DWG. (CS-C10) THEY ARE NOT SHOWN HERE.
 6. ALL FUNCTION CALLOUTS ARE ACTIVE HI UNLESS "LO" IS DESIGNATED.
 7. JH-110 USES LOCATE COMMAND FROM RTZ BOARD FOR LIFTER OUT SENSE.
 8. REMOVE R3 JUMPER ONLY IF RTZ ALLOCATOR OR AUTO LOCK IS NOT USED.

**PARTS LIST
CONTROL LOGIC BOARD
PCA2500-0027**

Molex Connector 9CIR	09-52-3093
Molex Connector 15CIR	09-52-3153
Diode	1N4004

TEST A 3/29/84 TP3 CH 2

LINE FUNCTION TABLE (SEE NOTE 1)	
J47-PIN 4	CONT. SEL. SW. EXT
-5	CONT. SEL. SW. COMM
-6	STOP LINK THRU
-7	STOP LINK THRU
-8	REF. SIG. SEL. SW. FIXED
-9	VAR. SPEED POT. C.W.
-10	SPEED SEL. SW. 7.5 IPS (NOT USED)
-11	SPEED SEL. SW. 15 IPS LO
-12	VAR. SPEED POT. C.W.
-13	REF. SIG. SEL. SW. COMM. (SPEED SEL. SW. 30 IPS HI)
-14	REF. SIG. SEL. SW.
-15	SPEED SEL. SW. COMM.

LIST REF DES. USED
 V1
 Q4
 CR14
 IC19
 C42
 R65

REF. DES. NOT USED
 C19,15,21,22
 IC11
 R12,24,35-36,44,45,50,51
 Q1

- NOTES:
- MOTHER BD. MOLEX CODE:
 - ⊗ - HARNESS FROM REAR
 - ⊙ - HARNESS FROM FRONT
 - U.S. RES. ARE 1/4W-5%
 RES. VALUES ARE IN OHMS
 - U.S. CAP. VOLT. RANGES ARE WORKING
 CAP. VALUES ARE IN MICROFARADS
 - U.S. DIODES ARE IN 914
 - P42-1,2, AND 3 ARE NON-EXISTENT
 - R54 IS USED IN MACHINES WITH
 RENCO TACH.
 - HI - ALL JH-114,
 JH-110 30/15/7 1/2 IPS,
 LO - JH-110 15/7 1/2/3 3/4 IPS
 - OP. FREQ. STRAPPING
 HI - JH-114 30/15 IPS
 JH-110 30/15/7 1/2 IPS
 LO - JH-114 15/7 1/2 IPS
 JH-110 15/7 1/2/3 3/4 IPS
 - TEST FREQ. STRAPPING
 19.2 KHZ - JH-114 30/15 IPS
 JH-110 30/15/7 1/2 IPS
 9.2 KHZ - JH-114 15/7 1/2 IPS
 JH-110 15/7 1/2/3 3/4 IPS
 - JH-114 - R39 IS A 39K RESISTOR
 JH-110 - R39 IS A 10K RESISTOR
 JH-110M - R39 IS A 39K RESISTOR
 - ⊕ ALSO TIES TO PIN 14 AT IC9, IC16,
 IC17 & IC18
 ⊕ ALSO TIES TO PIN 7 AT IC9, IC16,
 IC17 & IC18

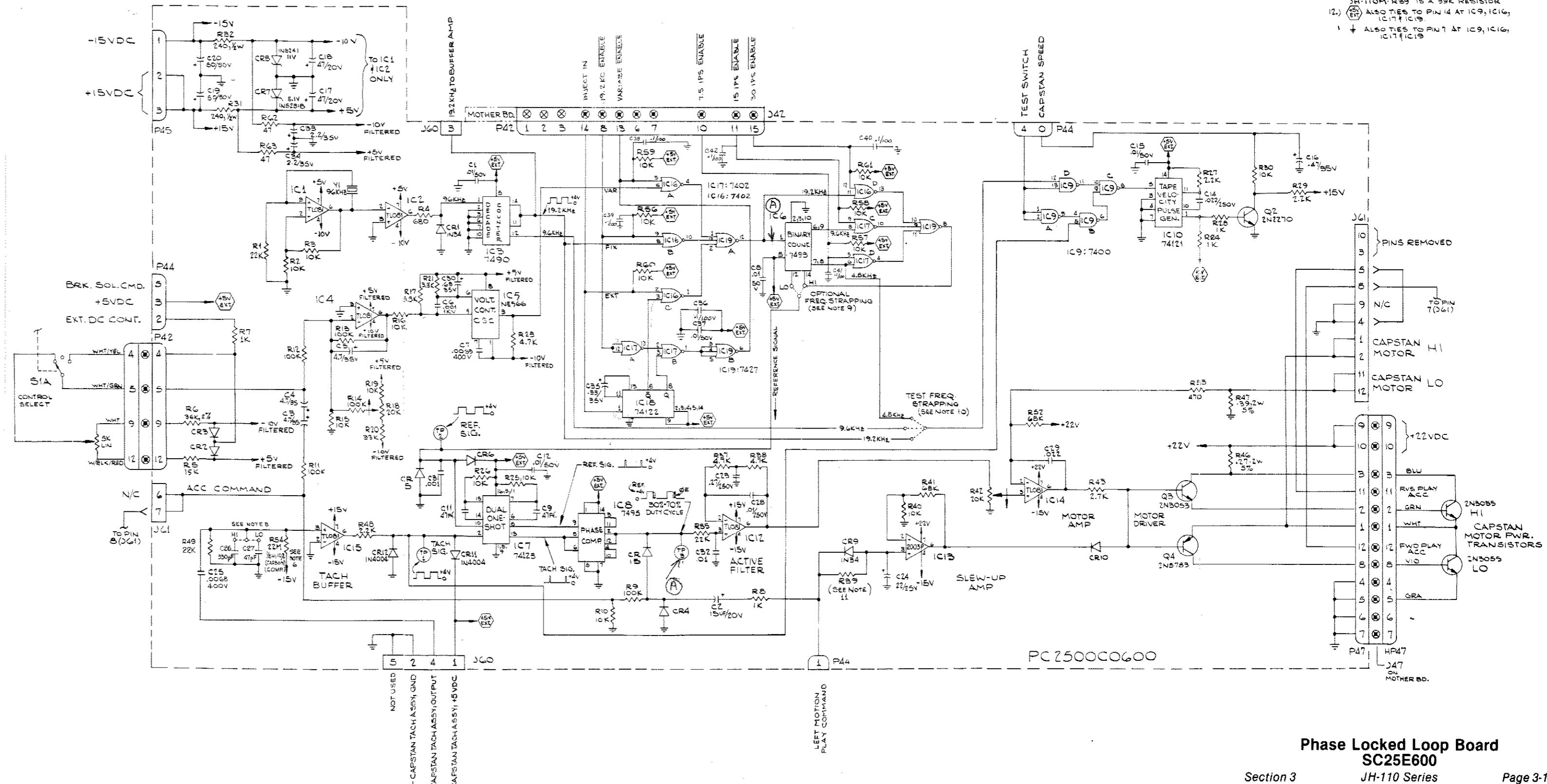
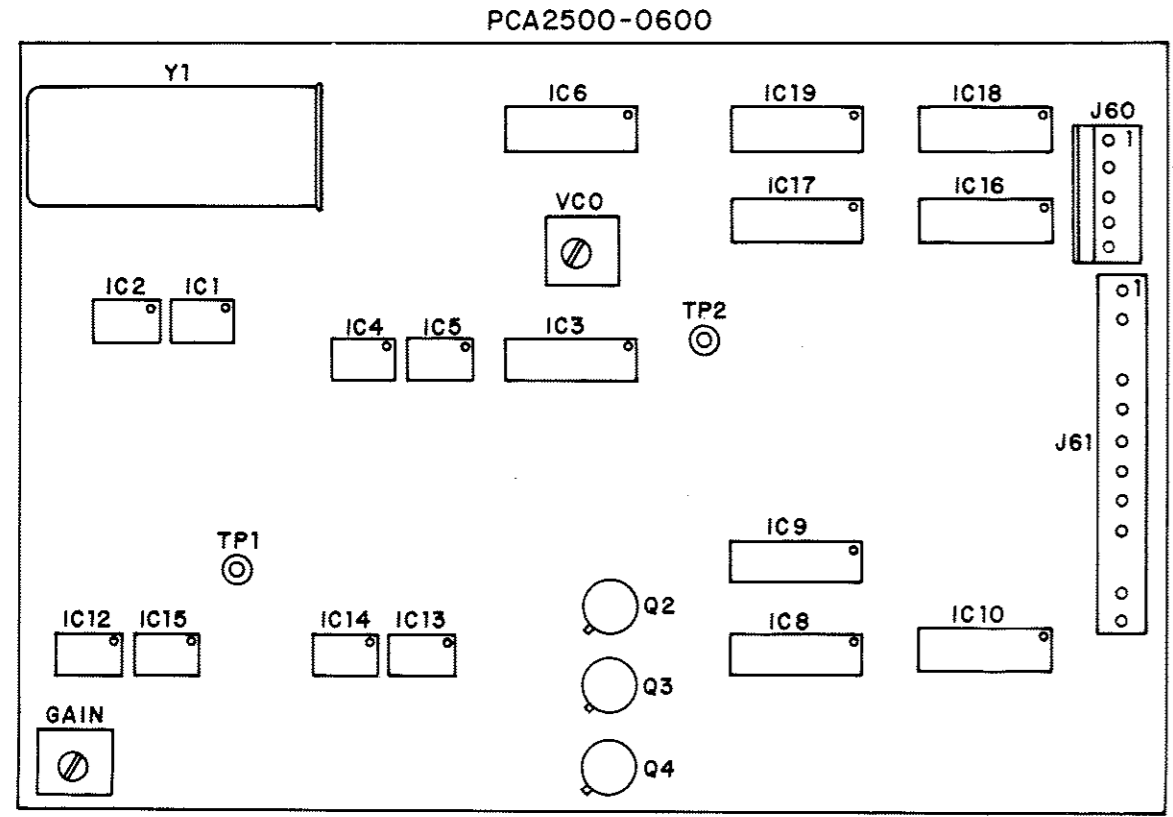

**PARTS LIST
PHASE LOCKED LOOP BOARD
PCA2500-600**

Molex Connector 3CIR	09-52-3030
Molex Connector 5 Pin	09-55-1052
12 Pin Molex Connector	09-64-1121
Diode	1N34
Diode	1N4004
Zener Diode	1N5231B-5.1V
Zener Diode	1N5241-11V
NPN Transistor	2N2270
NPN Transistor, High Speed Switch	2N3053
PNP Transistor	2N5783
Crystal	96kHz
Function Genreator	NE566
Potentiometer	TAPCOT20K-1T
Op Amp	TL081CP

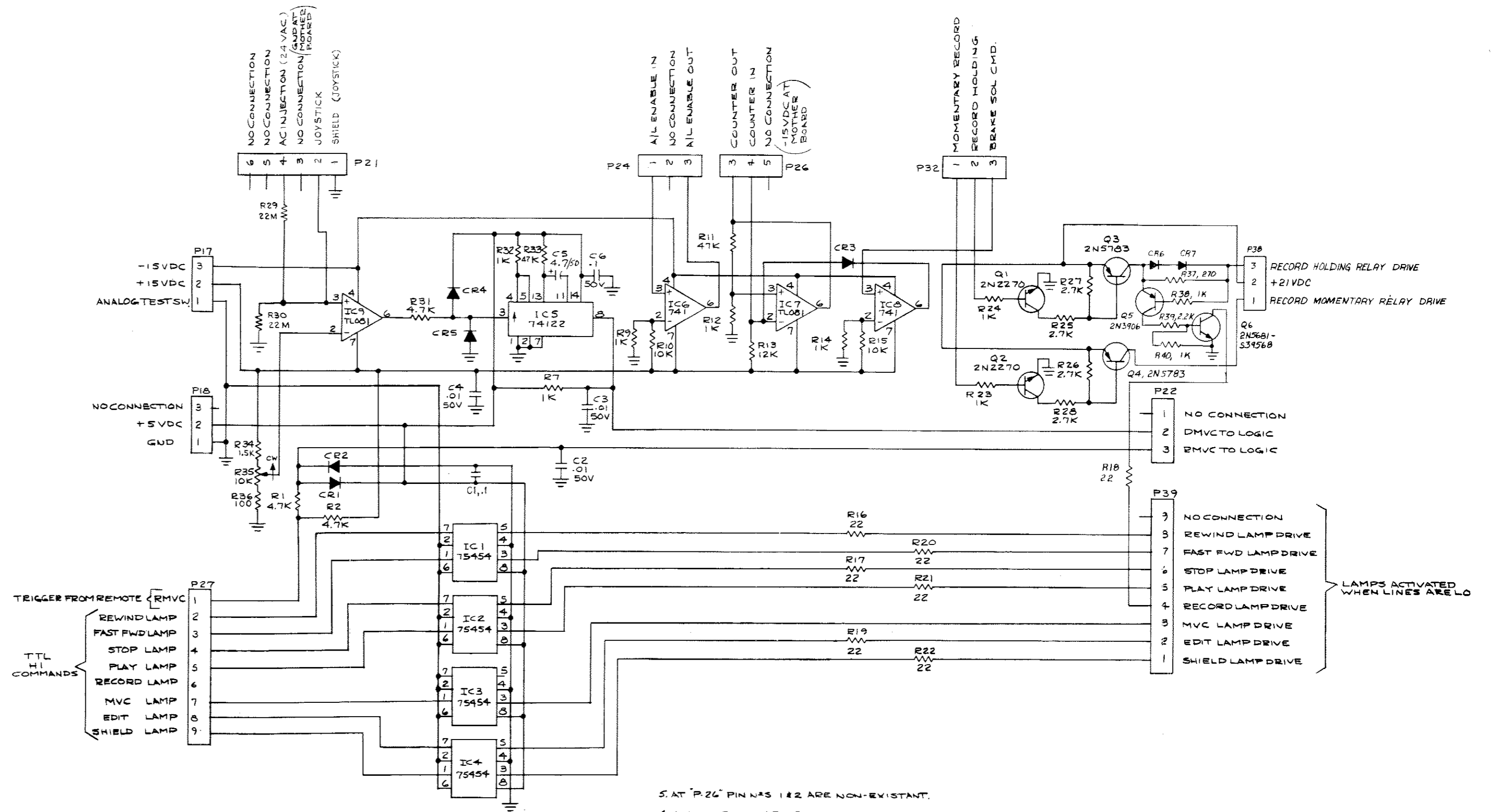
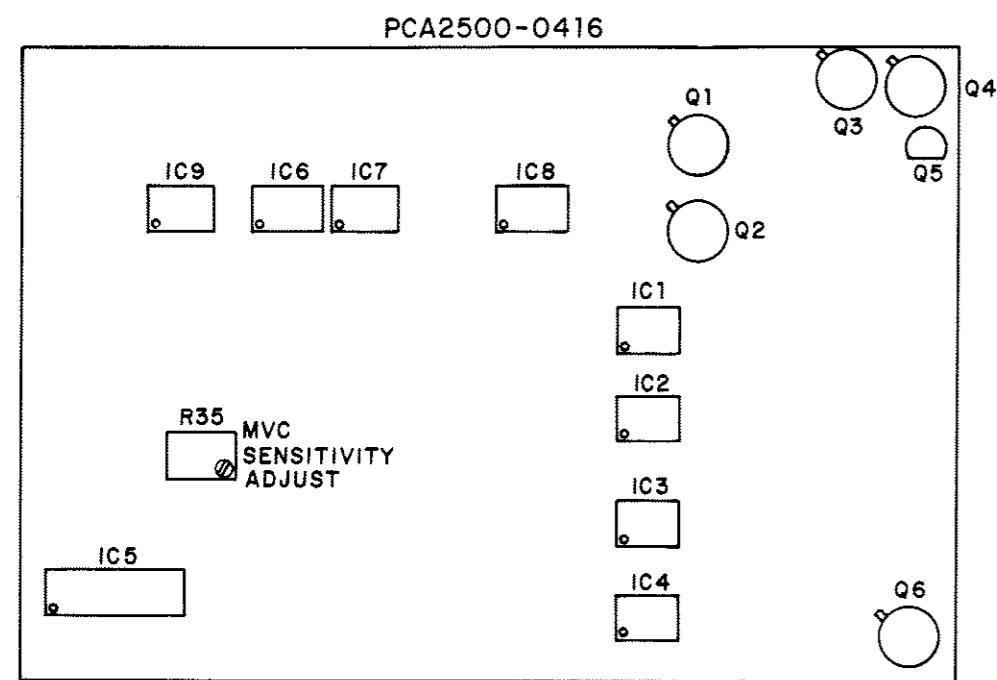

- 5. AT "P26" PIN NOS 1 & 2 ARE NON-EXISTANT.
 - 4. ALL VOLTAGES ARE D.C.
 - 3. ALL DIODES ARE IN 4004.
 - 2. ALL RESISTORS ARE IN OHMS, ±5%, 1/2 W.
 - 1. ALL CAPACITORS ARE IN MICROFARADS.
- NOTES: UNLESS OTHERWISE SPECIFIED.

PARTS LIST
INTERFACE/LAMP DRIVER BOARD
PCA2500-0416-00

Molex Connector	09-52-3030
Diode	1N4004
NPN Transistor	2N2270
PNP Transistor	2N5783
Op Amp	741CP
Op Amp	TL081CP
Potentiometer	TAPCPOT1MEG-18T
Retriggerable One Shot	74122

Electronic Flutter Dampener Board

SC26B1008

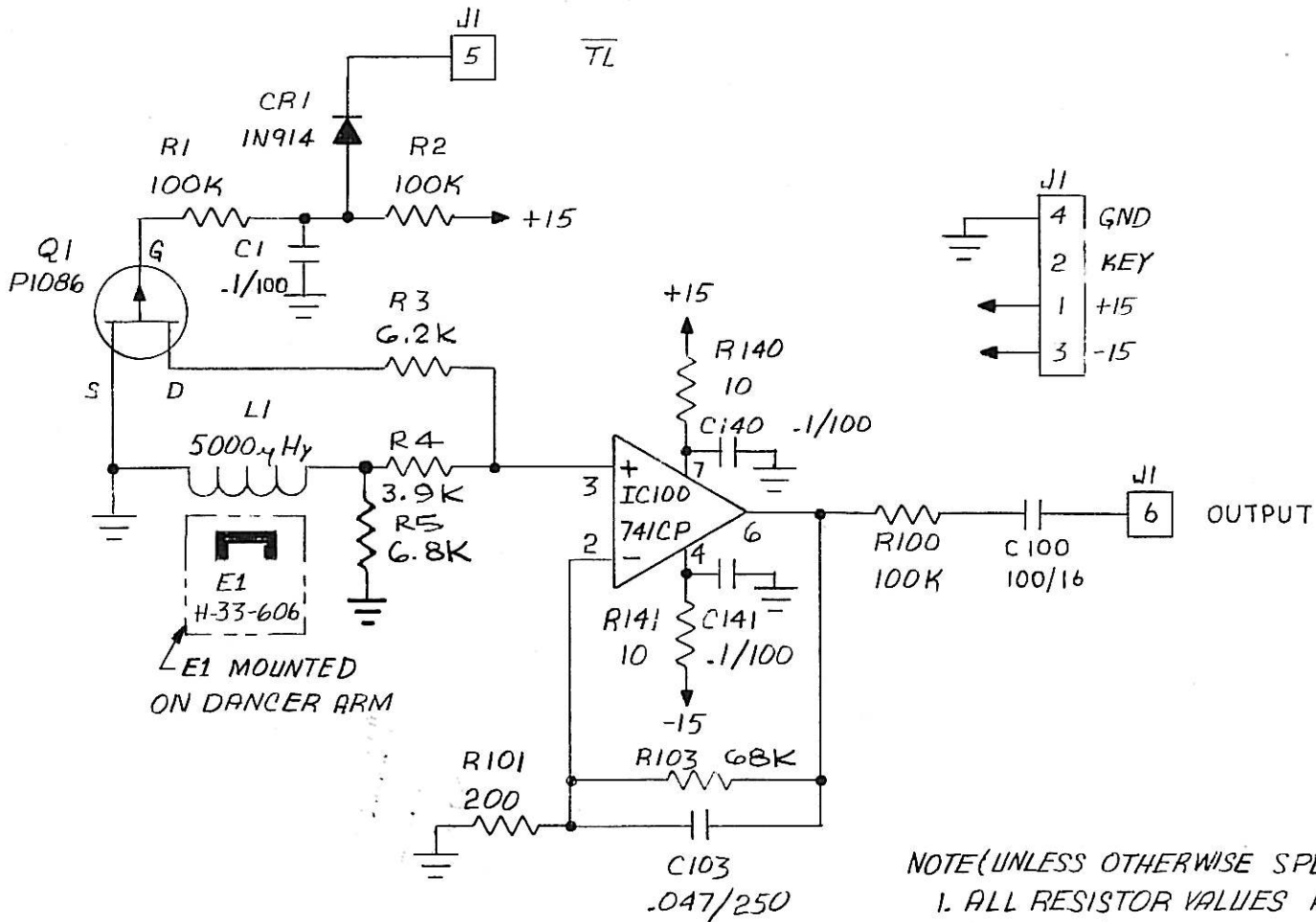

E1 MOUNTED ON DANCER ARM

NOTE (UNLESS OTHERWISE SPECIFIED)
 1. ALL RESISTOR VALUES ARE IN OHMS, 1/4 W, 5%.
 2. ALL CAPACITOR VALUES ARE IN μ F/VOLTS.

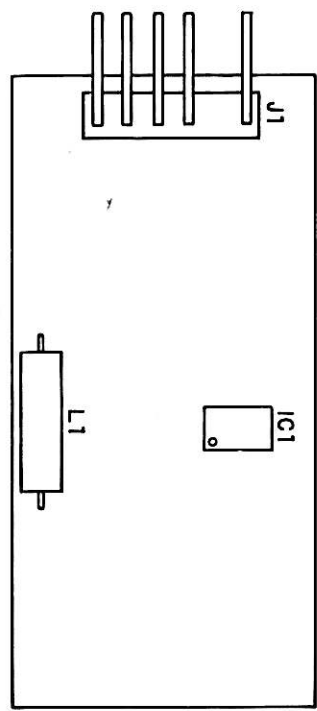



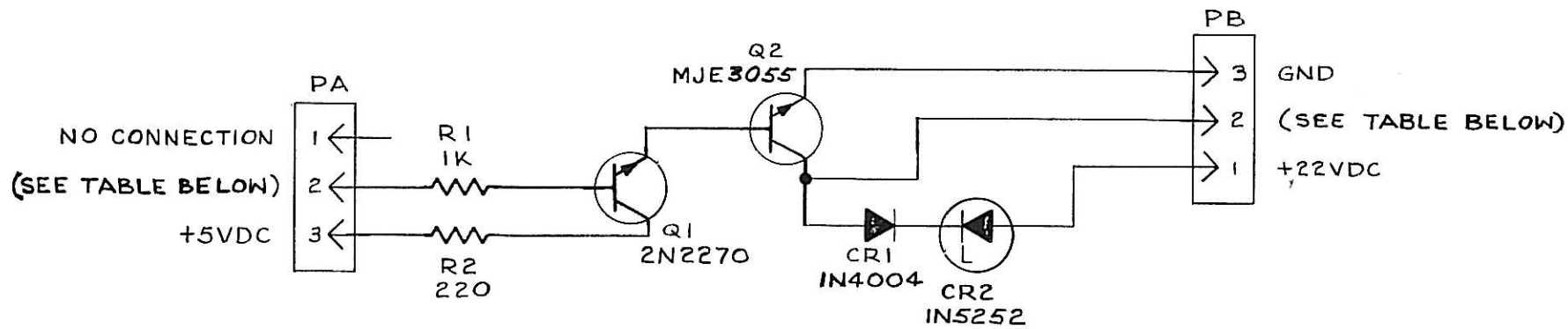

DRIVER BD	PA	PA-2 FUNCTION	PB	PB-2 FUNCTION
BRAKE SOL.	P41	BRAKE LOGIC COMM.	P37	BRAKE SOL. DRIVE
PLAY SOL.	P35	PLAY LOGIC COMMAND	P34	PLAY SOL. DRIVE
"Z" ROLLER SOL.	P30	"Z" ROLLER LOGIC COMM.	P29	"Z" ROLLER SOL. DRIVE
LIFTER SOL.	P25	LIFTER LOGIC COMM.	P23	LIFTER SOL. DRIVE
SHIELD SOL.	P20	SHIELD LOGIC COMM.	P16	SHIELD SOL. DRIVE

PARTS LIST
SOLENOID DRIVER BOARD
PCA2500-0042

3 Pin Molex Connector	09-64-1031
Diode	1N4004
Zener Diode 24 Volt	1N5252B-24V
NPN Transistor	2N2270
NPN Transistor	MJE-3055

Photo Sensor Board
SC26B160
JH-110 SERIES

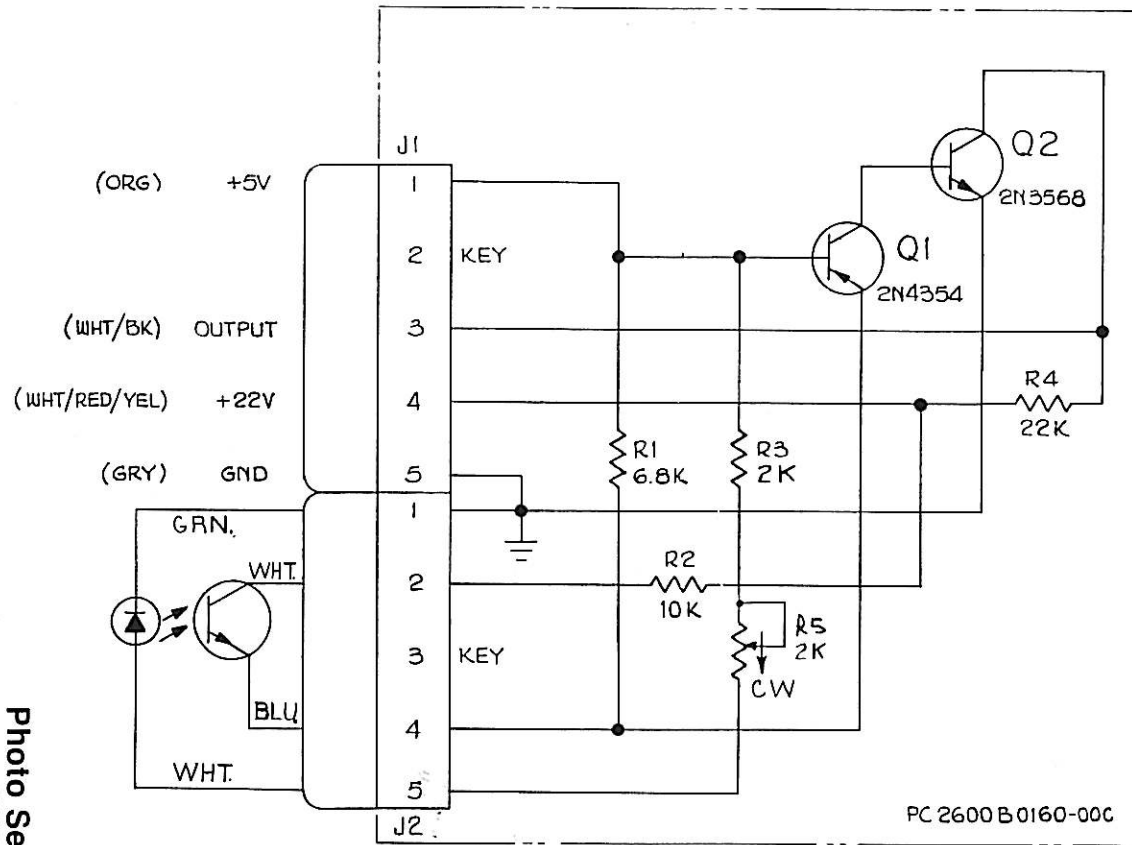

NOTE:

1. ALL RESISTOR VALUES ARE IN OHMS, 1/4 W, 5%.

PARTS LIST
PHOTO SENSOR AMP BOARD
PCA 2600-0160

10 Pin Right Angle Molex Connector	09-66-1101
PNP Transistor	2N4354
NPN Transistor	PN3568
Potentiometer	SAPCPOT2K-18T

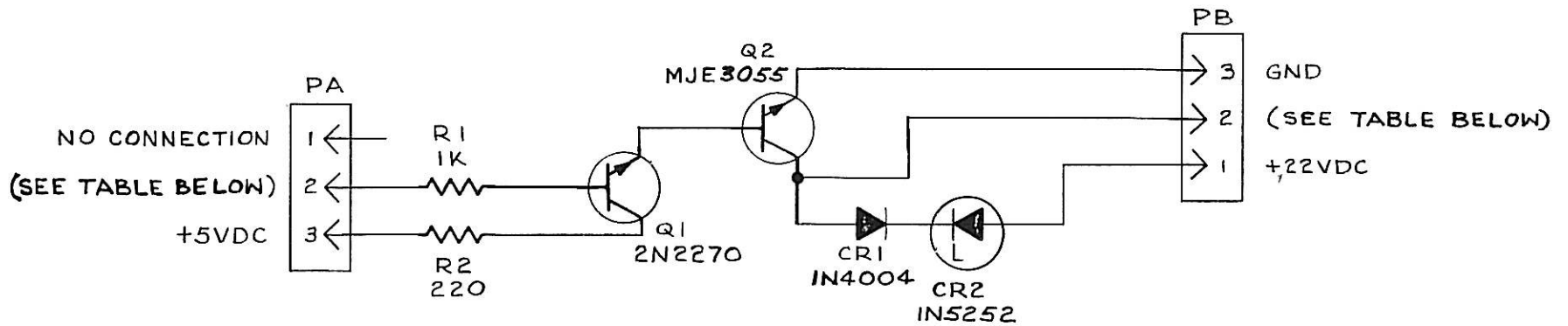

DRIVER BD	PA	PA-2 FUNCTION	PB	PB-2 FUNCTION
BRAKE SOL.	P41	BRAKE LOGIC COMM.	P37	BRAKE SOL. DRIVE
PLAY SOL.	P35	PLAY LOGIC COMMAND	P34	PLAY SOL. DRIVE
"Z" ROLLER SOL.	P30	"Z" ROLLER LOGIC COMM.	P29	"Z" ROLLER SOL. DRIVE
LIFTER SOL.	P25	LIFTER LOGIC COMM.	P23	LIFTER SOL. DRIVE
SHIELD SOL.	P20	SHIELD LOGIC COMM.	P16	SHIELD SOL. DRIVE

PARTS LIST
SOLENOID DRIVER BOARD
PCA2500-0042

3 Pin Molex Connector	09-64-1031
Diode	1N4004
Zener Diode 24 Volt	1N5252B-24V
NPN Transistor	2N2270
NPN Transistor	MJE-3055

Photo Sensor Board
SC26B160
JH-110 SERIES

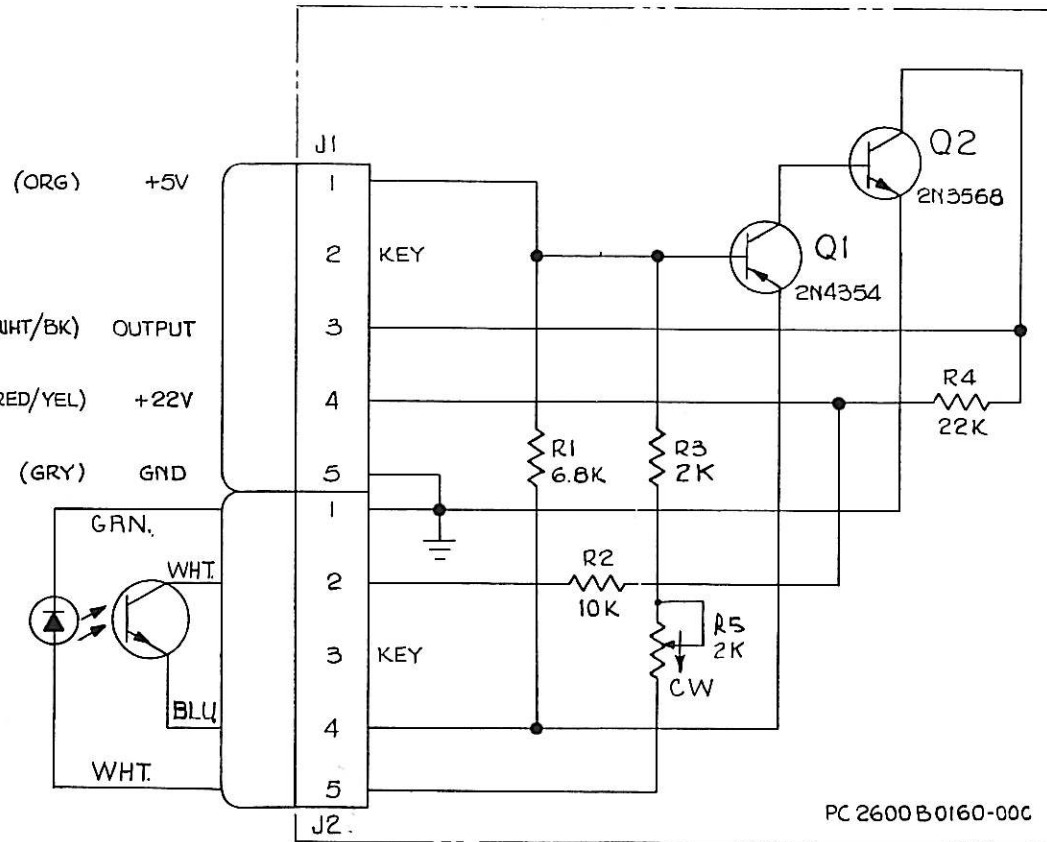

NOTE:

1.. ALL RESISTOR VALUES ARE IN OHMS, 1/4W, 5%



PARTS LIST
PHOTO SENSOR AMP BOARD
PCA 2600-0160

10 Pin Right Angle Molex Connector	09-66-1101
PNP Transistor	2N4354
NPN Transistor	PN3568
Potentiometer	SAPCPOT2K-18T

**PARTS LIST
TRANSPORT MOTHER BOARD
PCA2500-0085-01**

Molex Connector 3CIR	09-52-3031
Molex Connector, 3 Pin Locking	09-55-1032
Molex Connector, 4 Pin Locking	09-55-1042
Molex Connector, 5 Pin Locking	09-55-1052
Molex Connector, 3 Pin Non-locking	09-64-1032
Molex Connector, 3 Pin Non-locking	09-64-1033
Molex Connector, 4 Pin Non-locking	09-64-1042
Molex Connector, 6 Pin Non-locking	09-64-1062
Molex Connector, 8 Pin Non-locking	09-64-1082
Molex Connector, 8 Pin Non-locking	09-64-1083
Molex Connector, 9 Pin Non-locking	09-64-1092
Molex Connector, 12 Pin Non-locking	09-64-1123
Molex Connector, 3 Pin Locking Male	09-65-1030
Molex Connector, 4 Pin Locking	09-65-1041
Molex Connector, 5 Pin Locking	09-65-1051
Molex Connector, 8 Pin Locking	09-65-1081
Molex Connector, 10 Pin Locking	09-65-1101
Molex Connector, 12 Pin Locking	09-65-1121
NPN Transistor	2N5681-S39568
Surgistor Diode	ICTE-5-5V
Op Amp	TL081CP

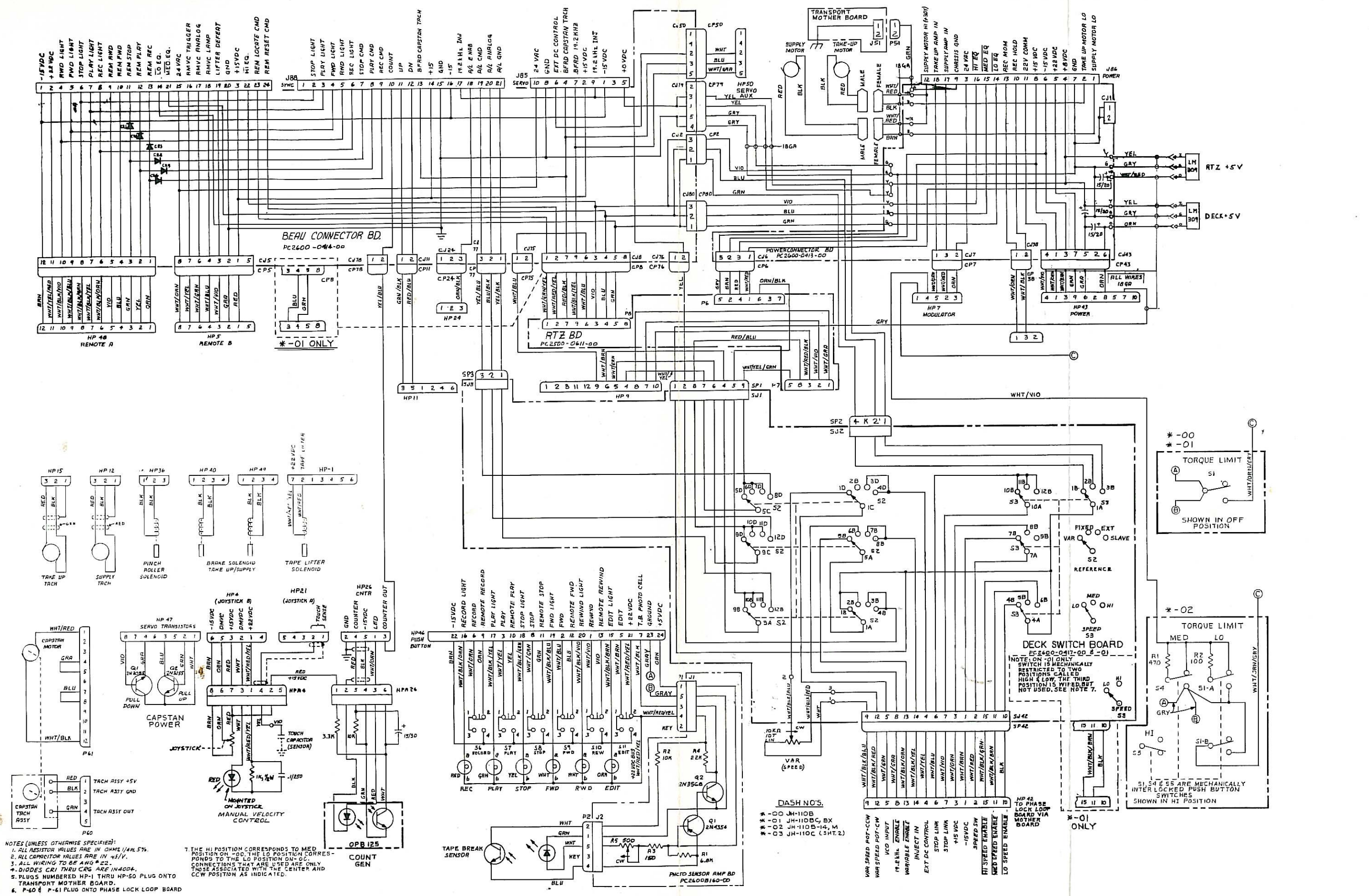

NOTES (UNLESS OTHERWISE SPECIFIED):
 1. ALL RESISTOR VALUES ARE IN OHMS UNLESS OTHERWISE SPECIFIED.
 2. ALL CAPACITOR VALUES ARE IN μF UNLESS OTHERWISE SPECIFIED.
 3. ALL WIRING TO BE AWG #22.
 4. DIODES CR1 THRU CR6 ARE IN 400V.
 5. PLUGS NUMBERED HP-1 THRU HP-50 PLUG ONTO TRANSPORT MOTHER BOARD.
 6. P-60 & P-61 PLUG ONTO PHASE LOCK LOOP BOARD.

7. THE HI POSITION CORRESPONDS TO MED POSITION ON -00. THE LO POSITION CORRESPONDS TO THE LO POSITION ON -00. CONNECTIONS THAT ARE USED ARE ONLY THOSE ASSOCIATED WITH THE CENTER AND CCW POSITION AS INDICATED.

DASH NO'S.

* -00	JH-110B
* -01	JH-110B-C, B-X
* -02	JH-110B-14, M
* -03	JH-110C (SHT. 2)

**PARTS LIST
CAPSTAN TACH BOARD
PCA2500-0287-00**

Molex Connector, 5 Hole 09-50-3051

Photo Cell SP-7000-0212-00

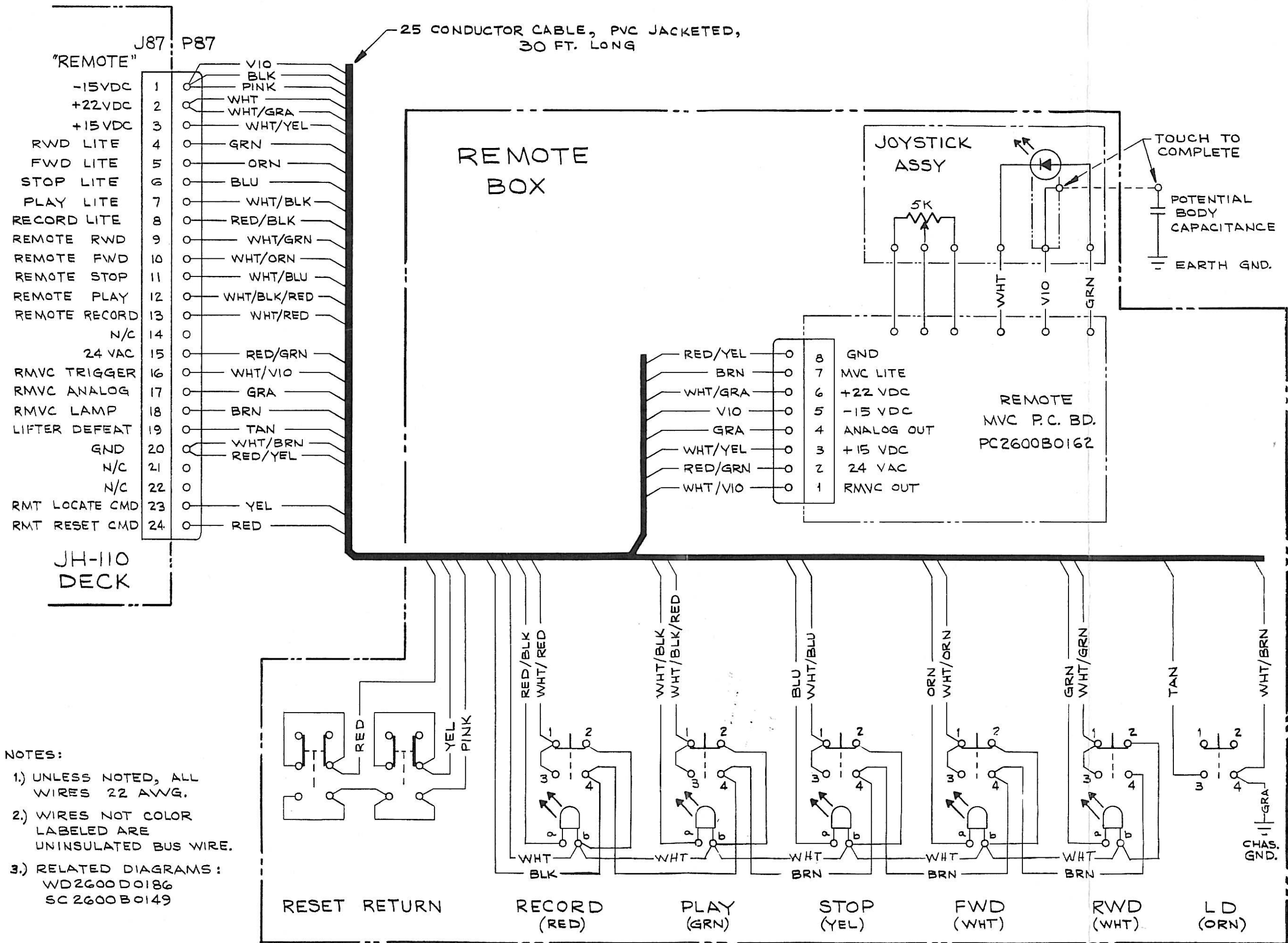

- NOTES:
- 1.) UNLESS NOTED, ALL WIRES 22 AWG.
 - 2.) WIRES NOT COLOR LABELED ARE UNINSULATED BUS WIRE.
 - 3.) RELATED DIAGRAMS:
 - WD2600D0186
 - SC2600B0149

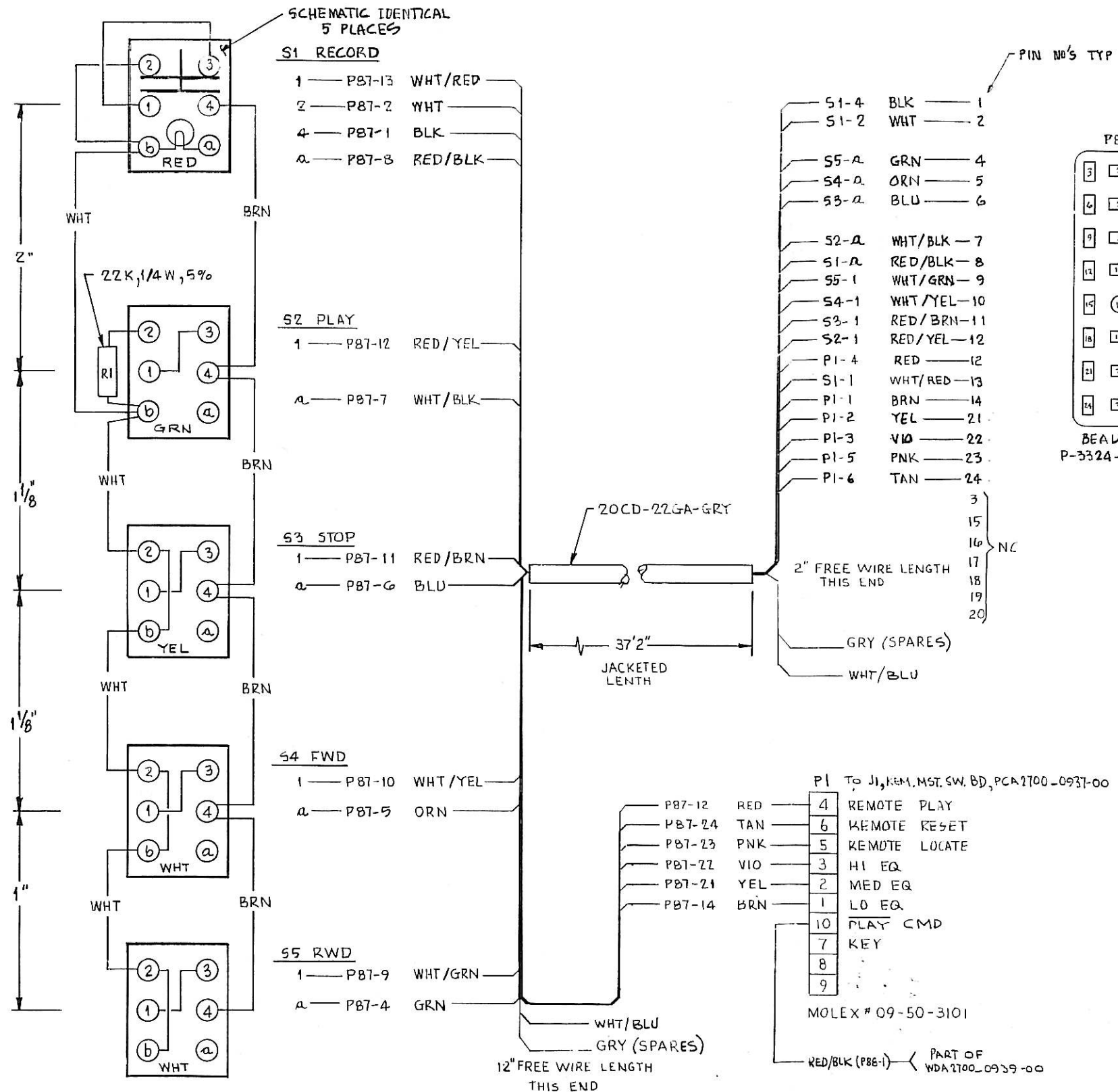

P87	FUNCTION
1	-15VDC
2	+22VDC
3	NOT USED
4	REM RWD LIGHT
5	REM FWD LIGHT
6	REM STOP LIGHT
7	REM PLAY LIGHT
8	REM RECORD LIGHT
9	REM RWD SW
10	REM FWD SW
11	REM STOP SW
12	REM PLAY SW
13	REM RECORD SW
14	LO EQ.
15 THRU 19	NOT USED
20	GND
21	MED EQ
22	HI EQ.
23	REM LOCATE CMD
24	REM RESET CMD

NOTES:

1. ALL JUMPERS NOTED WITH COLORS TO BE AWG#22 STRANDED.
2. ALL UNMARKED JUMPERS TO BE AWG#22 BUSS WIRE.
3. OVERALL WIRE LENGTH IS 38'-4".

HEAD HOUSING ASSEMBLY

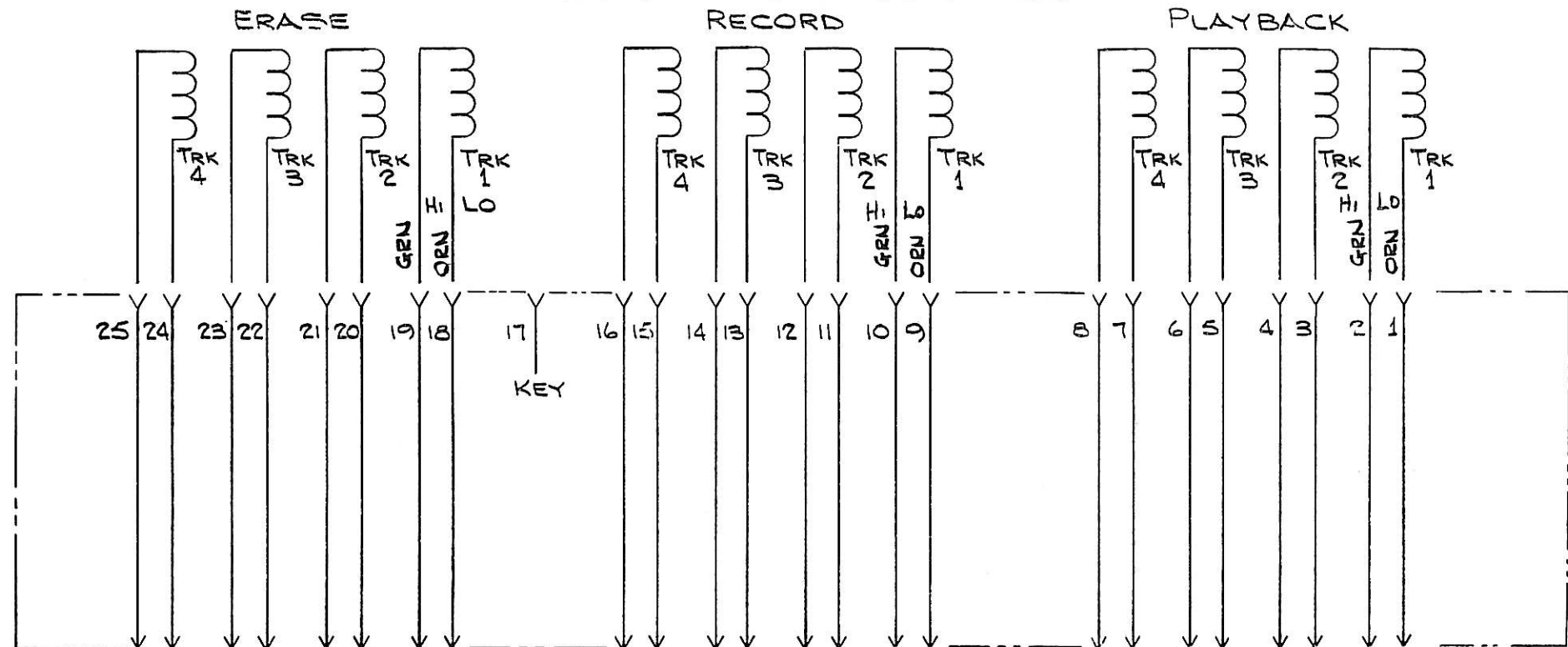

OPTION:
PRE RECORD
PLAYBACK

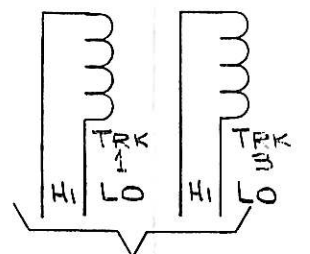

SEE ENGR. FOR OPTION
SYSTEM WIRING

PC2600C003

NOTE:

INSERT DUMMY CONTACT OR
SPRING CLIP IN HOLES
LETTERED "C", "H", "M", "S", "W",
& SMALL "A"

CABLING TO
AUDIO ELECTRONICS

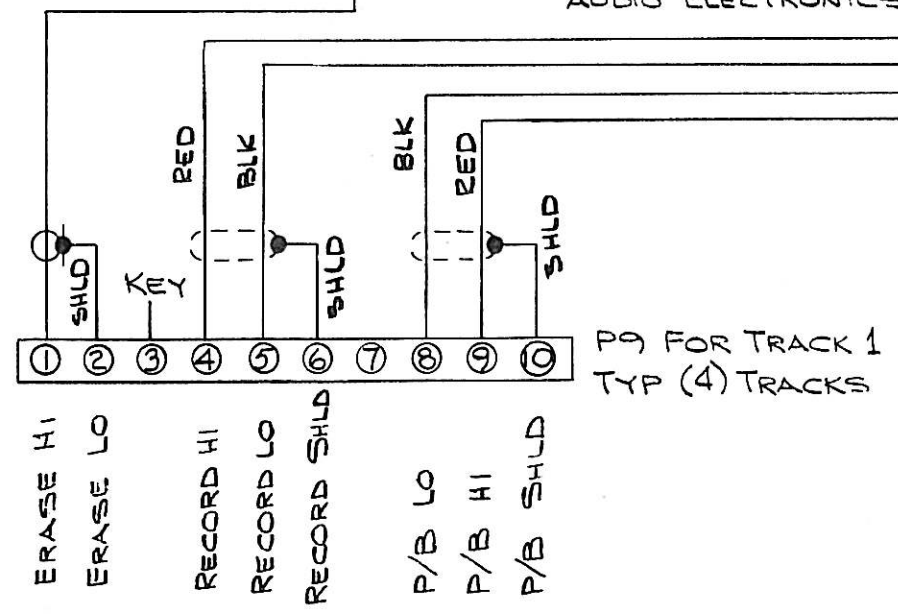

* HEAD CABLE ASSEMBLY CHART			
DASH NO.	PLAYBACK	RECORD	ERASE
-01	TRK1 THRU TRK4	TRK1 THRU TRK4	TRK1 THRU TRK4
-04	TRK1 & TRK 2	TRK1 & TRK 2	TRK1 & TRK 2
-05	TRK 1	TRK 1	TRK 1

Head Connector
SC26C003
JH-110 SERIES

Section 3

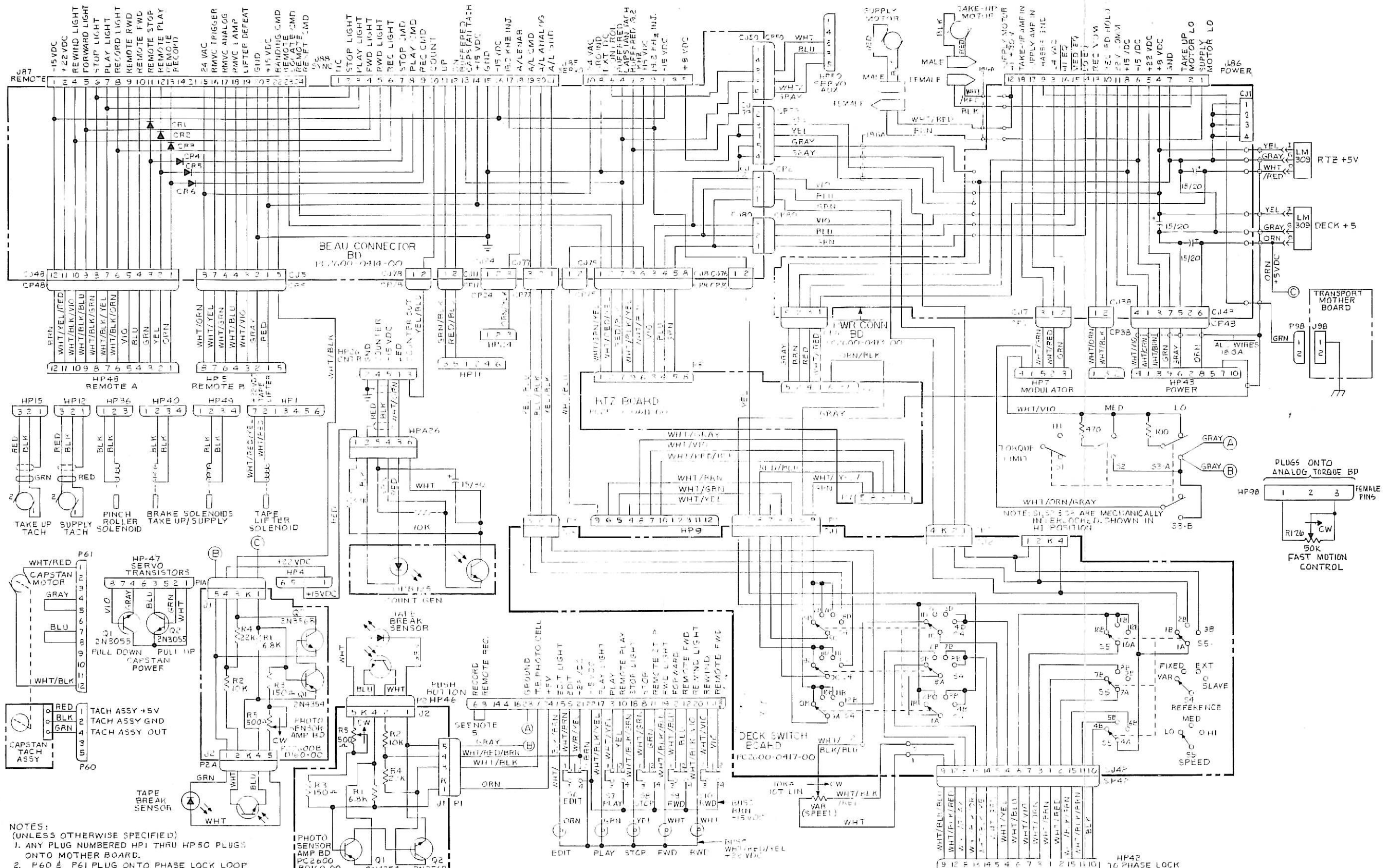

- NOTES:
(UNLESS OTHERWISE SPECIFIED)
1. ANY PLUG NUMBERED HP1 THRU HP50 PLUGS ONTO MOTHER BOARD.
 2. P60 & P61 PLUG ONTO PHASE LOCK LOOP BOARD.
 3. J85, J86, J87 & J88 MOUNT ON MOTHER BOARD FRAME.
 4. WIRE IS 22 GA.
 5. FOR JH-110M-D, THE TAPE PREVIEW SENSOR IS DELETED AND THE RECORD SWITCH IS ADDED. DELETE THE JUMPER FROM HP46-6 TO HP46-9.

6. ALL CAPACITOR VALUES ARE IN MICROFARADS/VOLTS.
7. DIODES CR1 THRU CR6 ARE IN4004.
8. ALL RESISTANCE VALUES ARE IN OHMS, 1/4W, 5%.

**Interconnect Harness, JH-110M
SC28F44
Section 3
JH-110 SERIES**

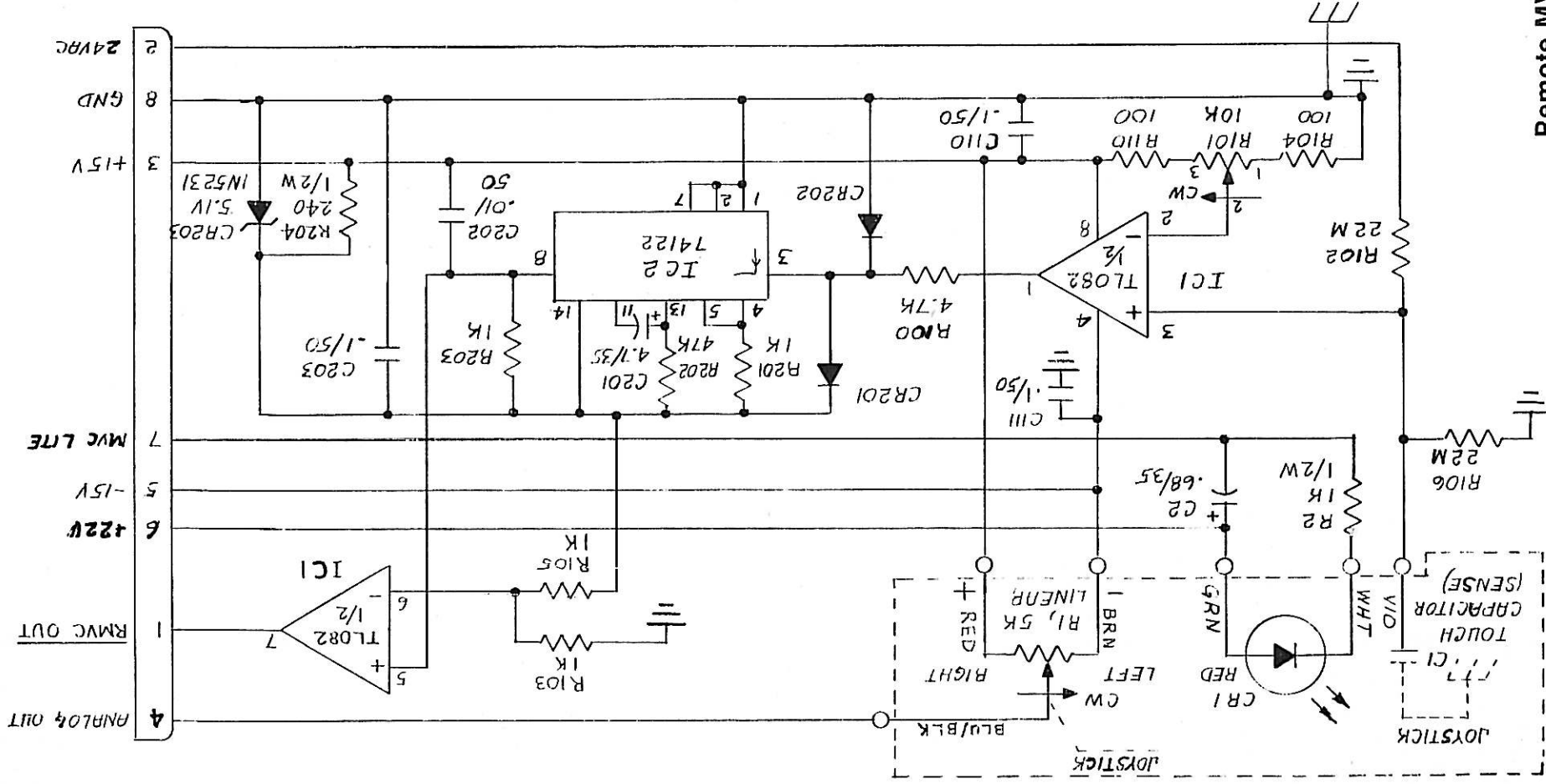

NOTES (UNLESS OTHERWISE SPECIFIED):
 1. ALL RESISTOR VALUES ARE IN OHMS, 1/4W, 5%.
 2. ALL CAPACITOR VALUES ARE IN μ F/VOLTS.
 3. ALL DIODES ARE IN4004.

Remote MVC
 SC26B1003
 JH-110 SERIES

Section 3

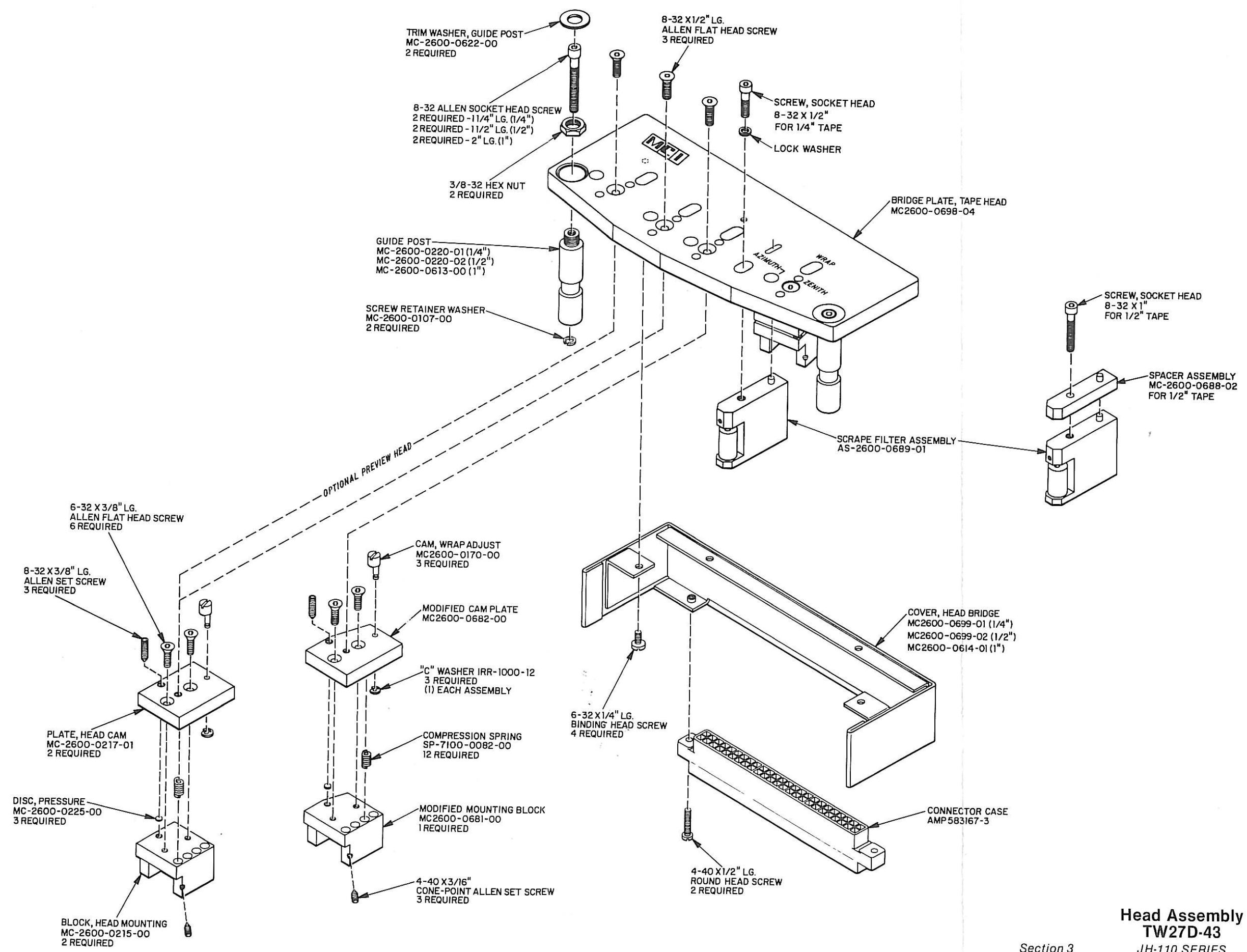

TW27D-43

Head Assembly
TW27D-43
JH-110 SERIES

Section 3

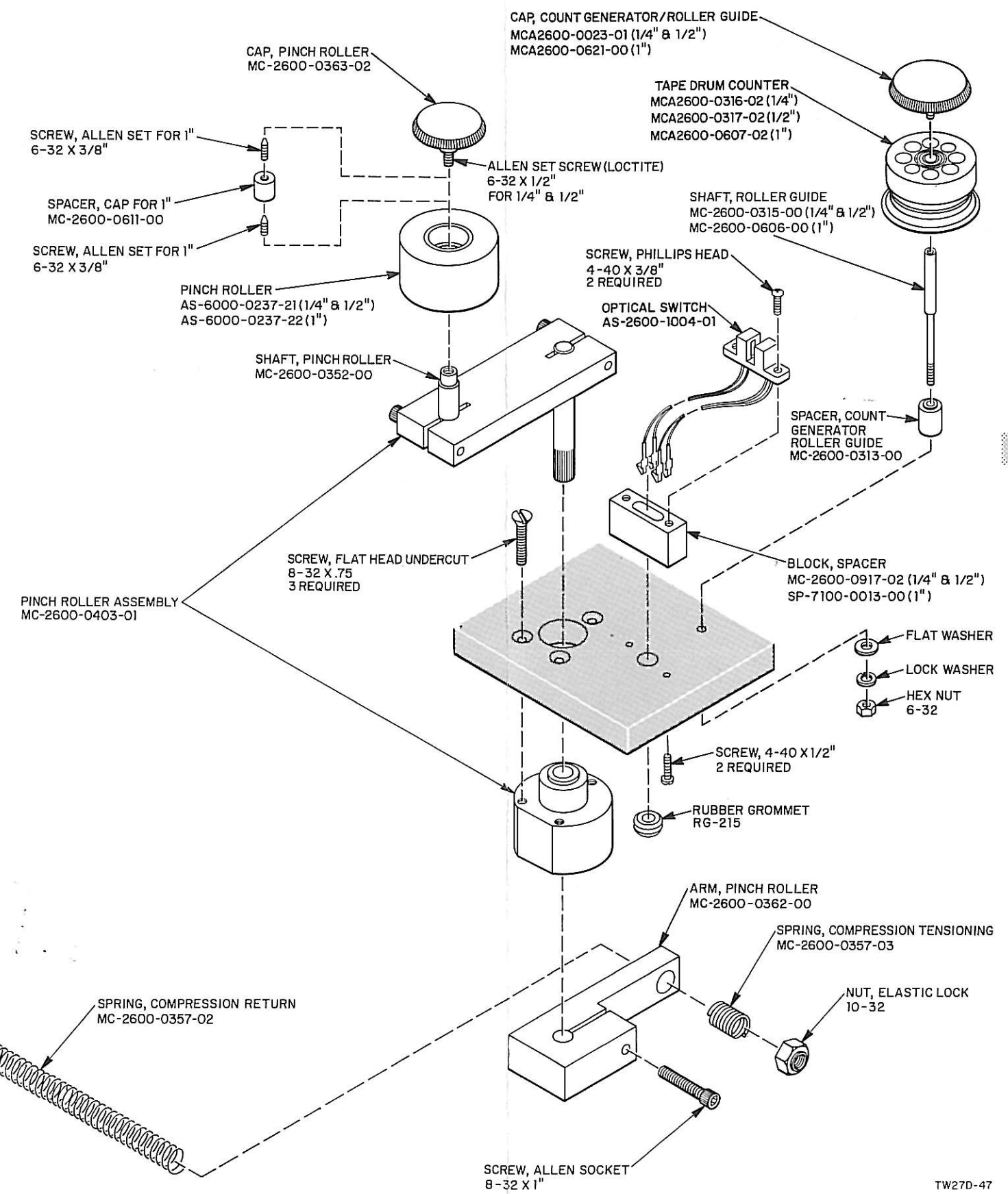
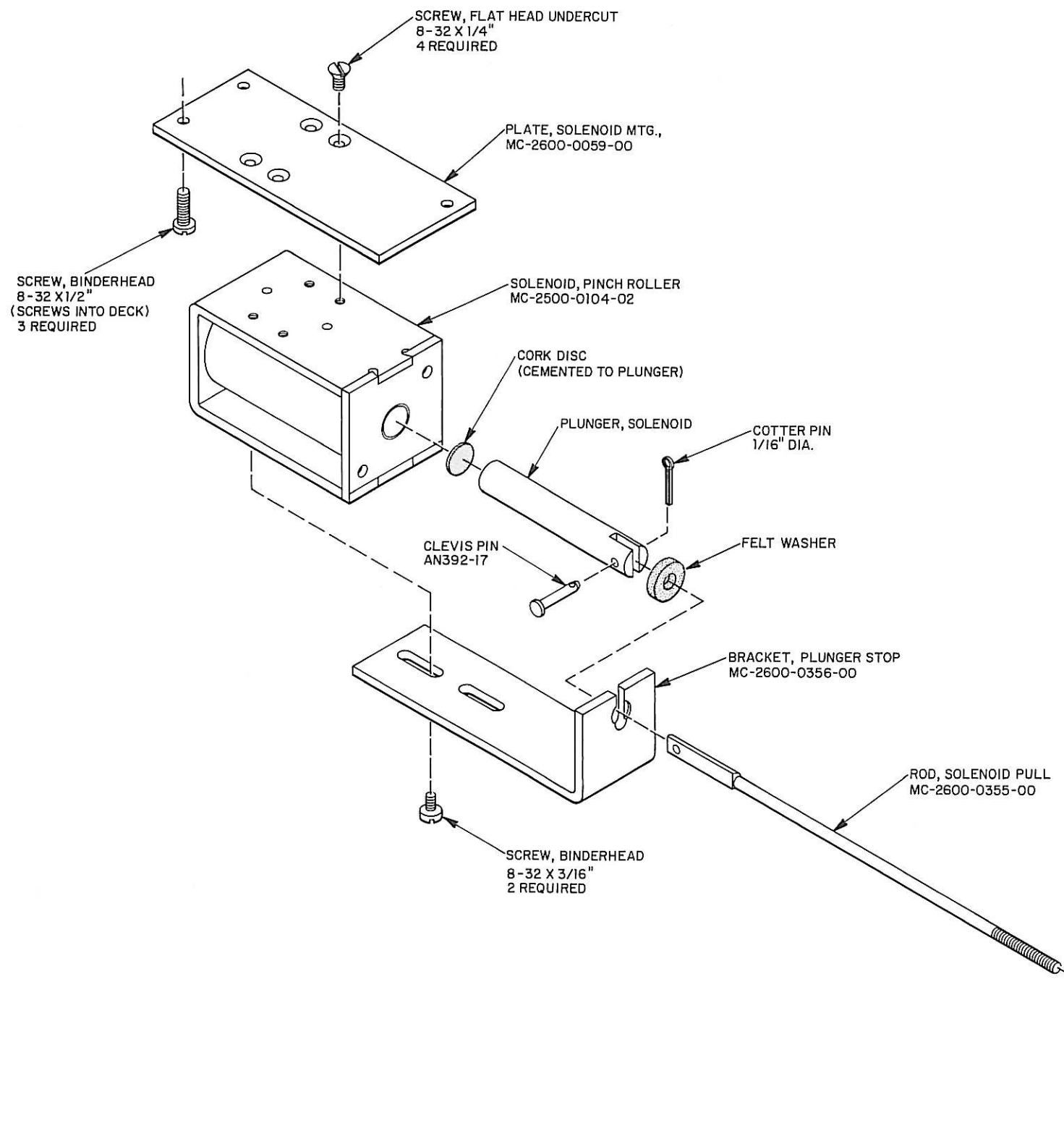

**Pinch Roller Assembly
TW27D-47**

Section 3

JH-110 SERIES

TW27D-47

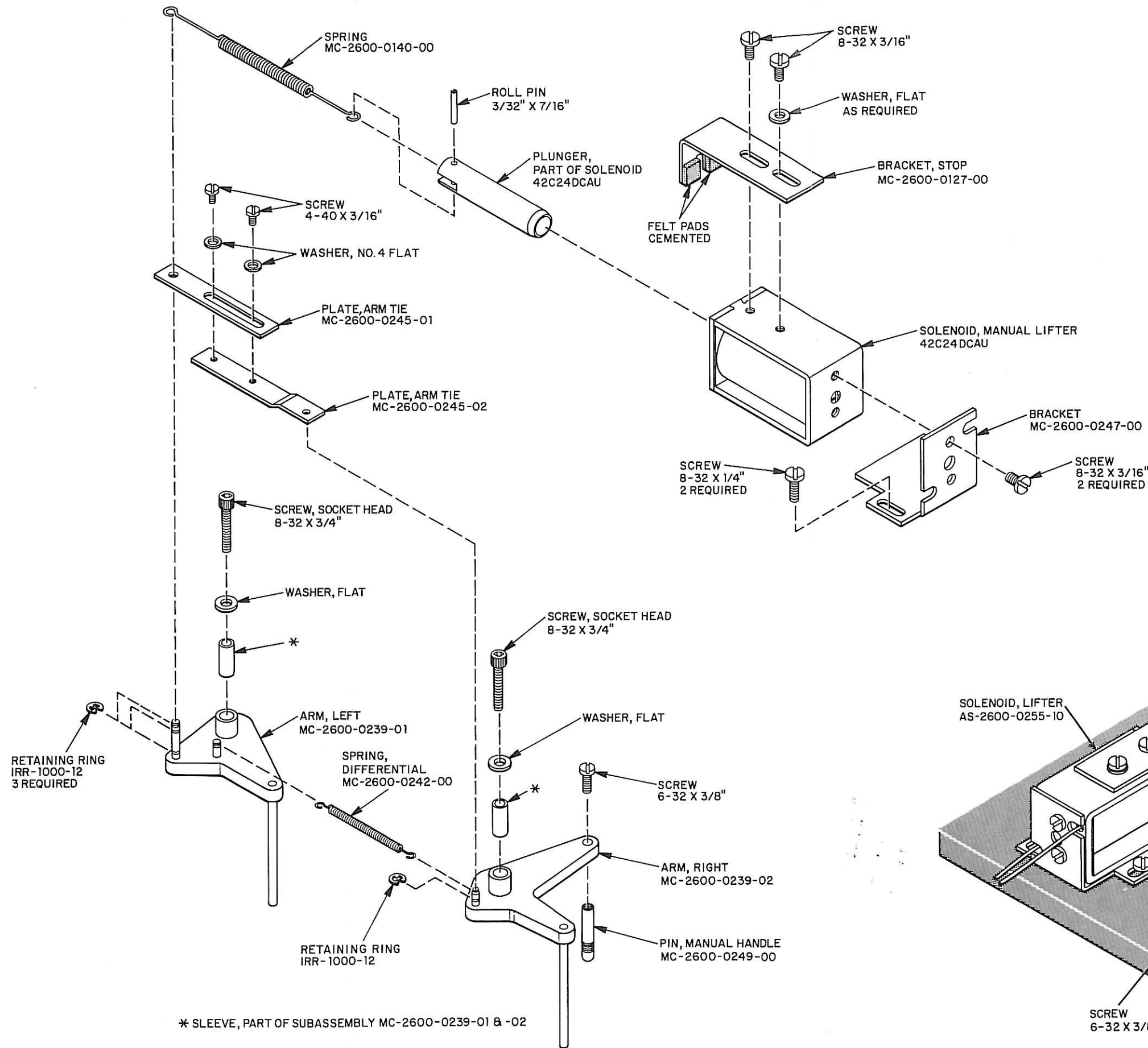

TAPE LIFTER ASSEMBLY
 AS-2600-0255-01 (LEFT ARM)
 AS-2600-0255-02 (RIGHT ARM)
 AS-2600-0255-03 (LEFT 110-8 TRACK)
 AS-2600-0255-04 (RIGHT 110-8 TRACK)

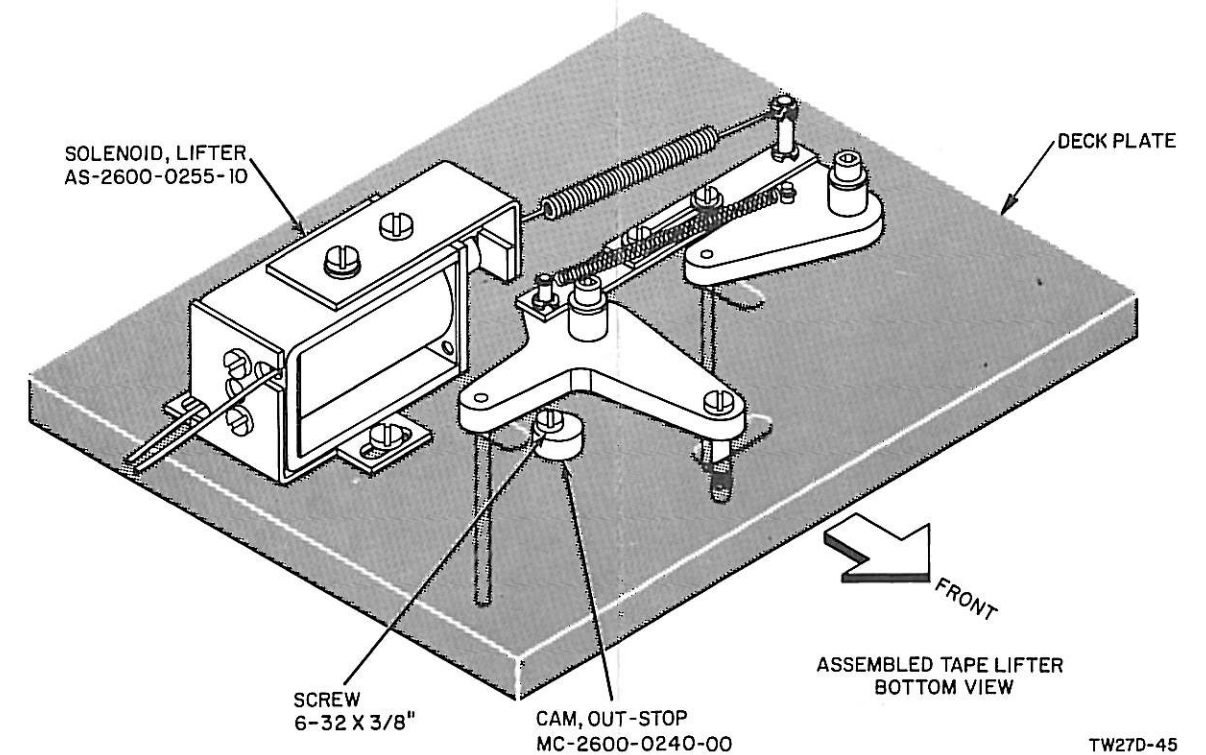

TW27D-45

Tape Lifter Assembly TW27D-45

Section 3

JH-110 SERIES

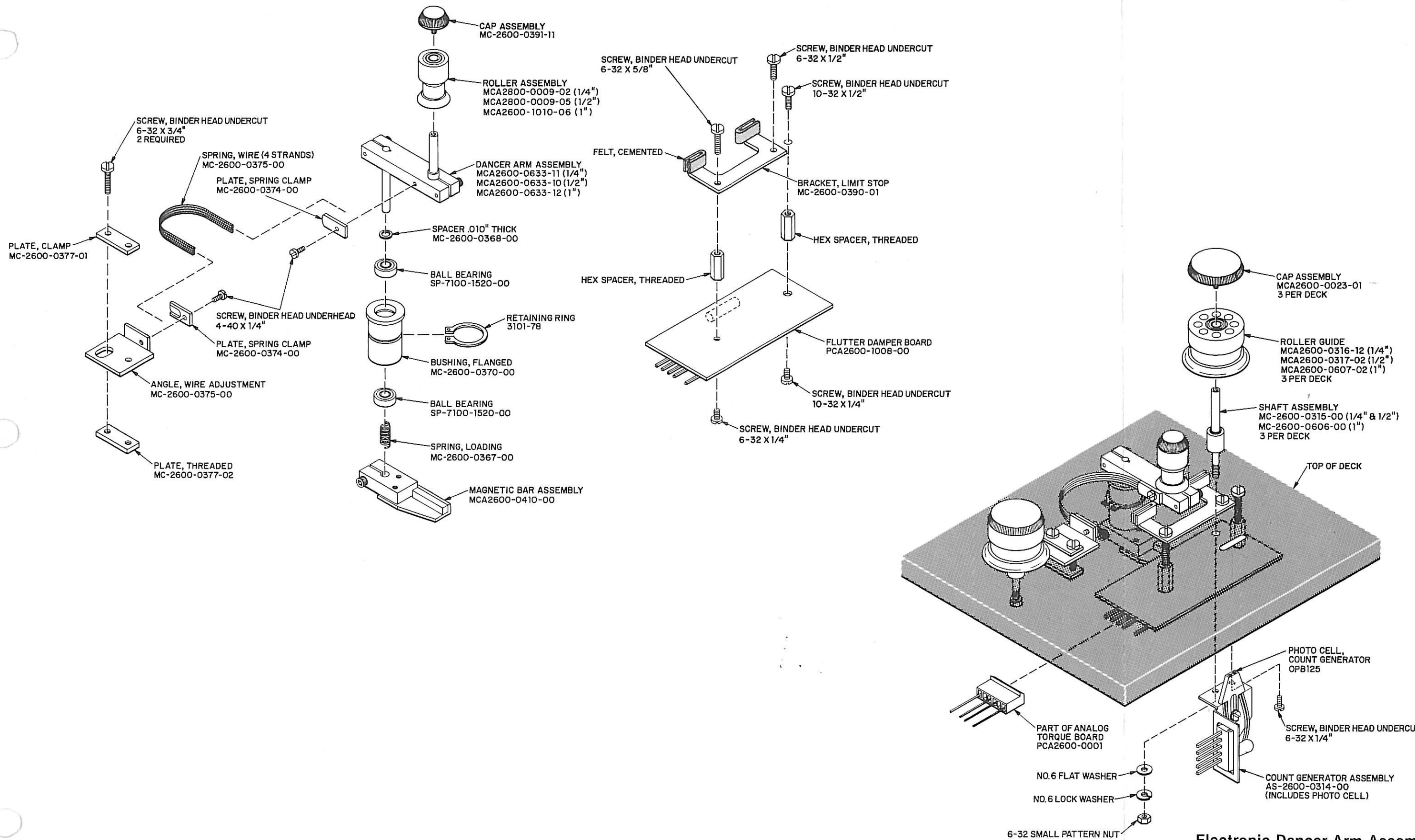

Electronic Dancer Arm Assembly
TW27D-81
 Section 3
 JH-110 Series

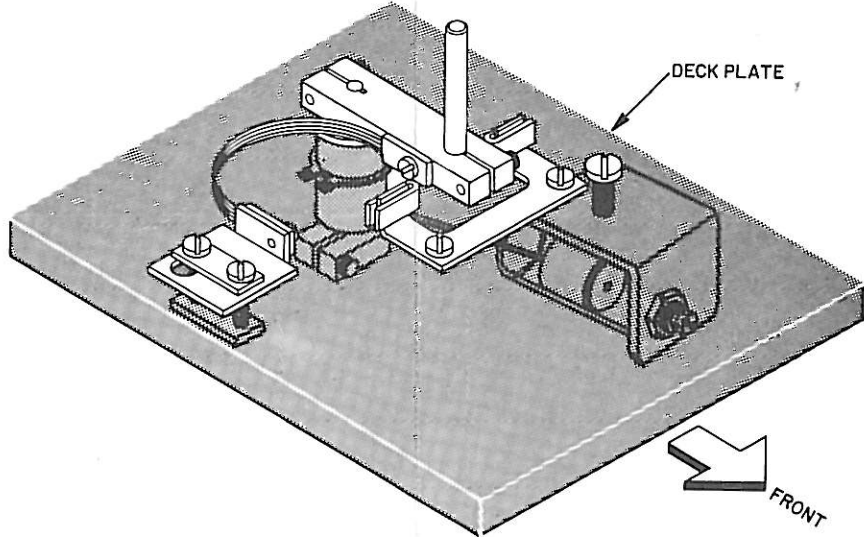
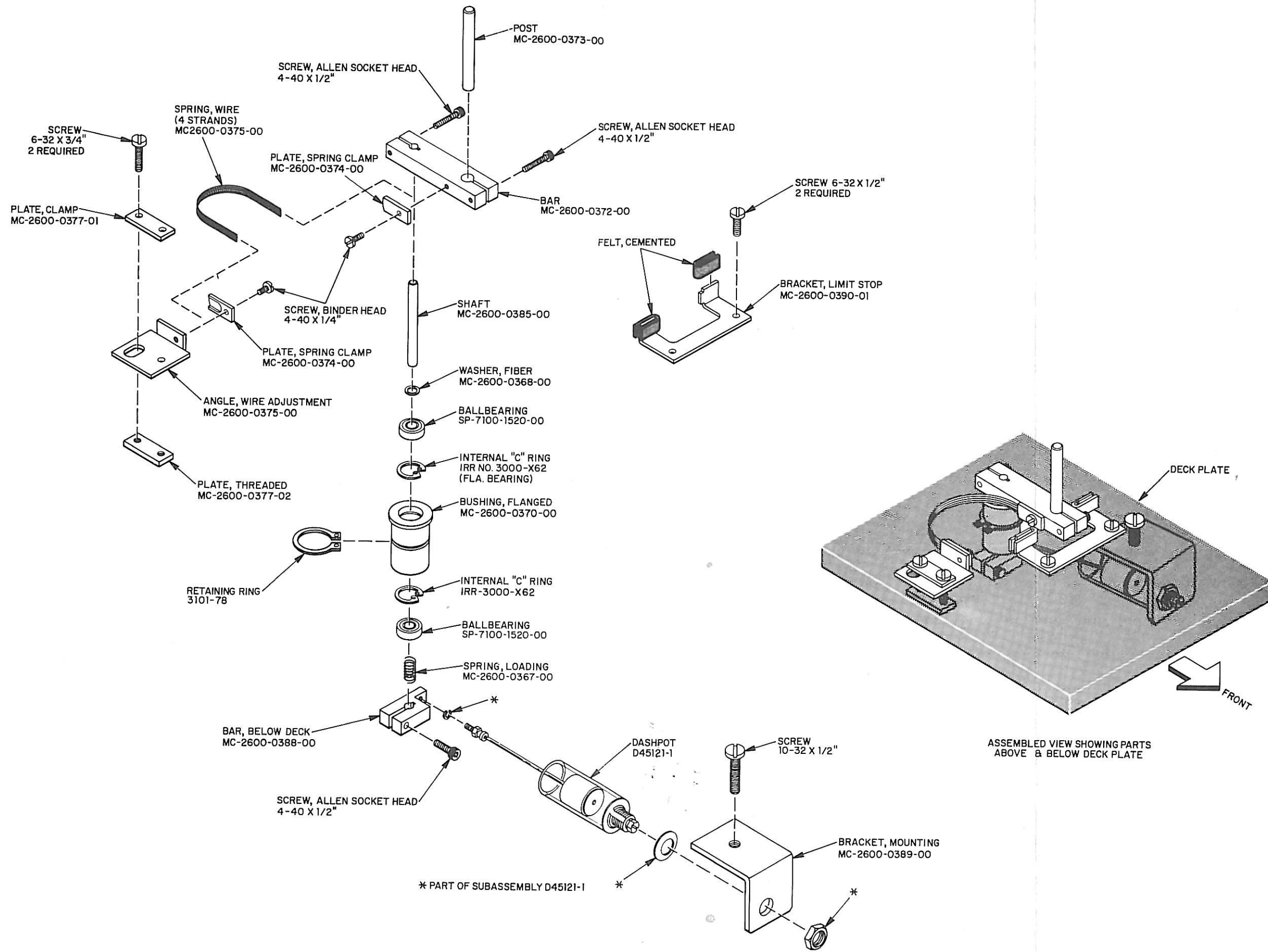

ASSEMBLED VIEW SHOWING PARTS ABOVE & BELOW DECK PLATE

**Dancer Arm Assembly (Air Dashpot)
TW27D-44**

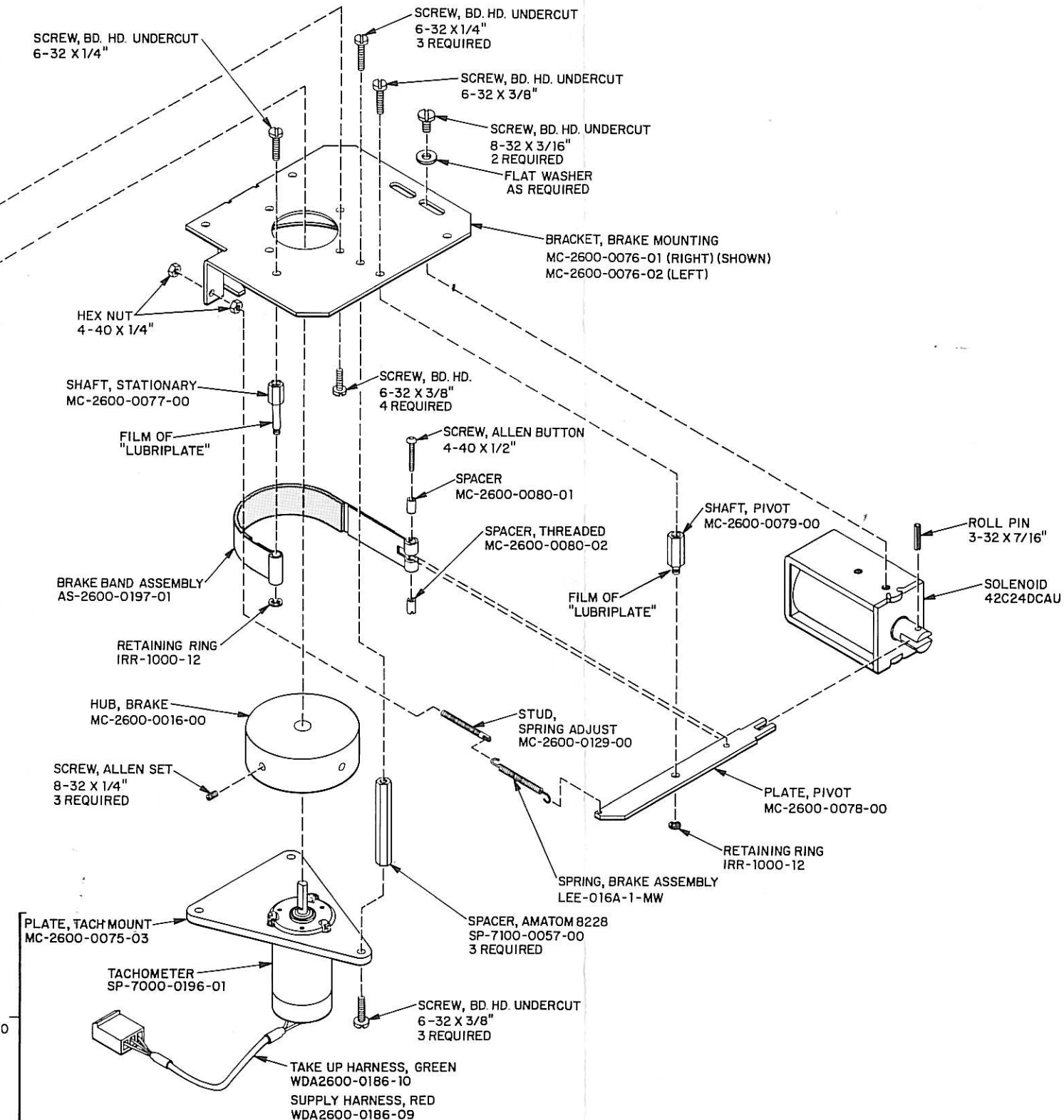
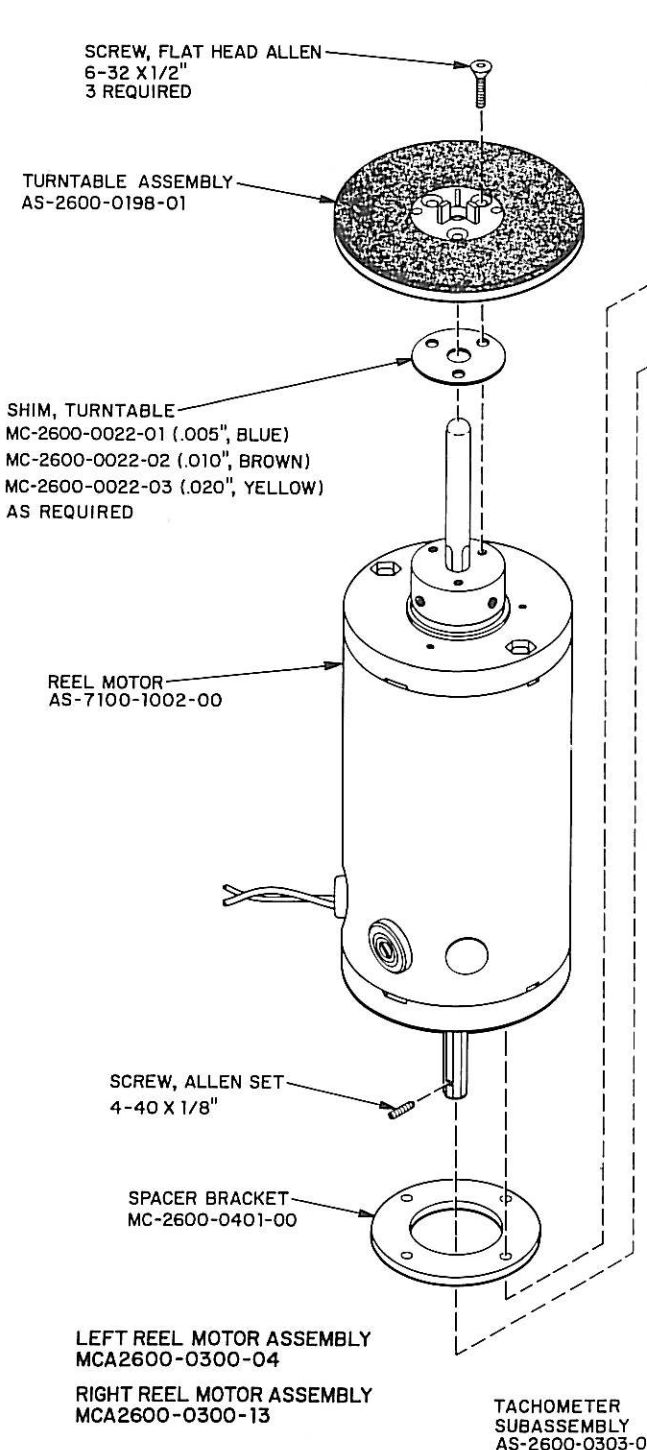
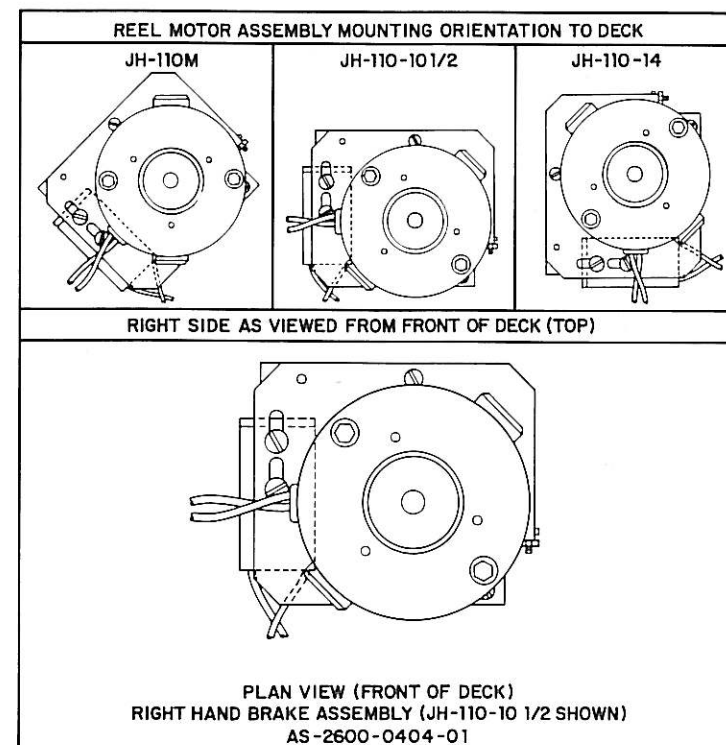
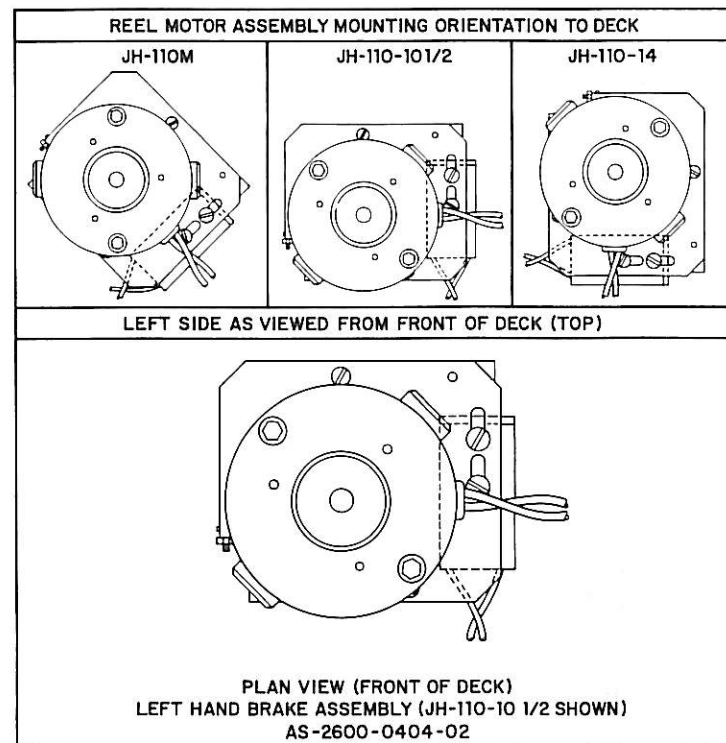

**Reel Motor Brake Assembly
TW27D-49**

Section 3

JH-110 SERIES

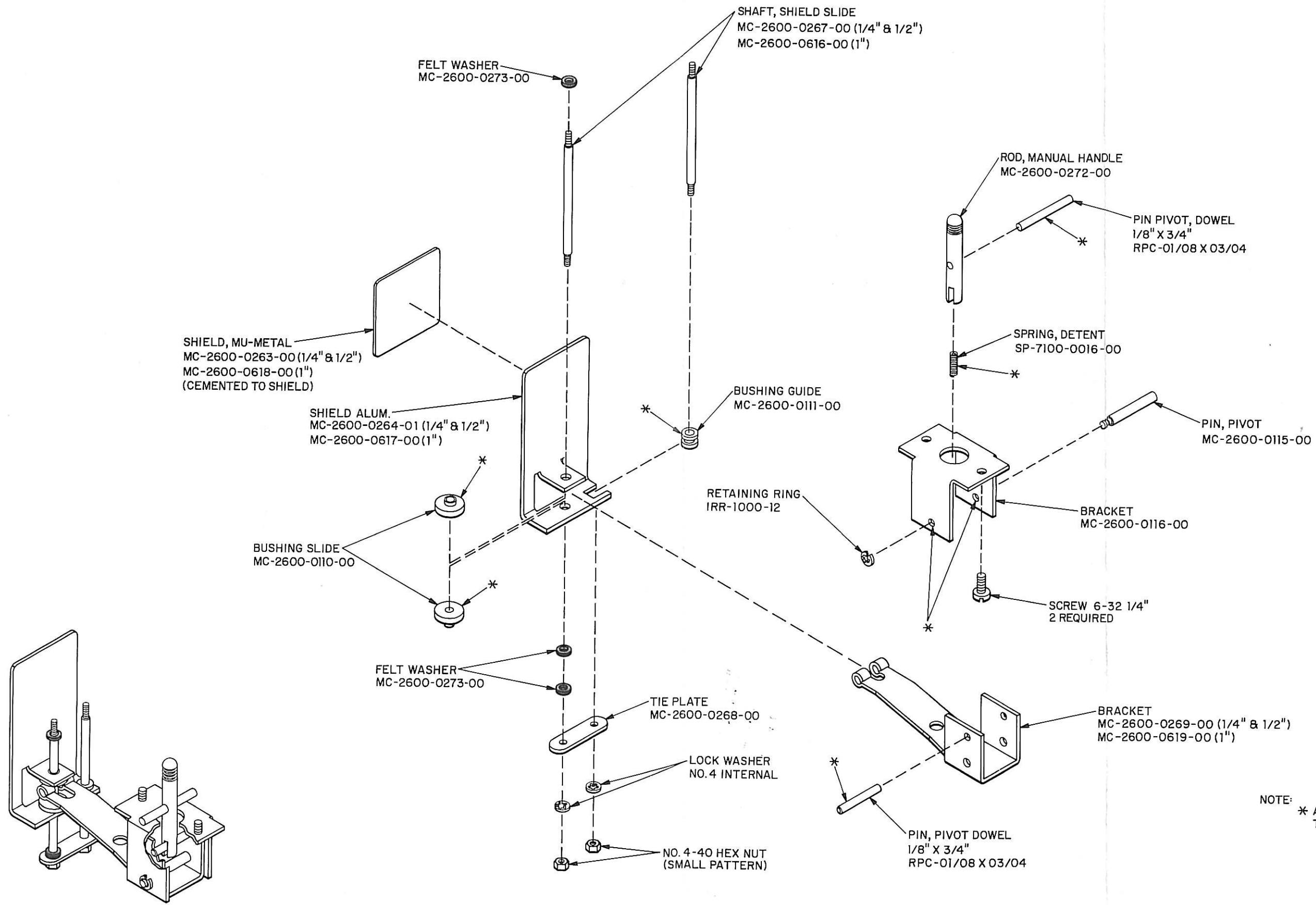

NOTE: * APPLY "LIGHT" LUBRICANT TO ALL MOVING PARTS.

TW27D-46
Head Shield Assembly
TW27D-46
 JH-110 SERIES

Section 3

TW27D-46

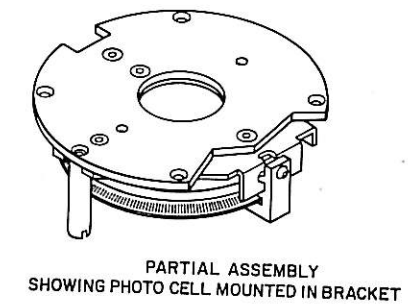
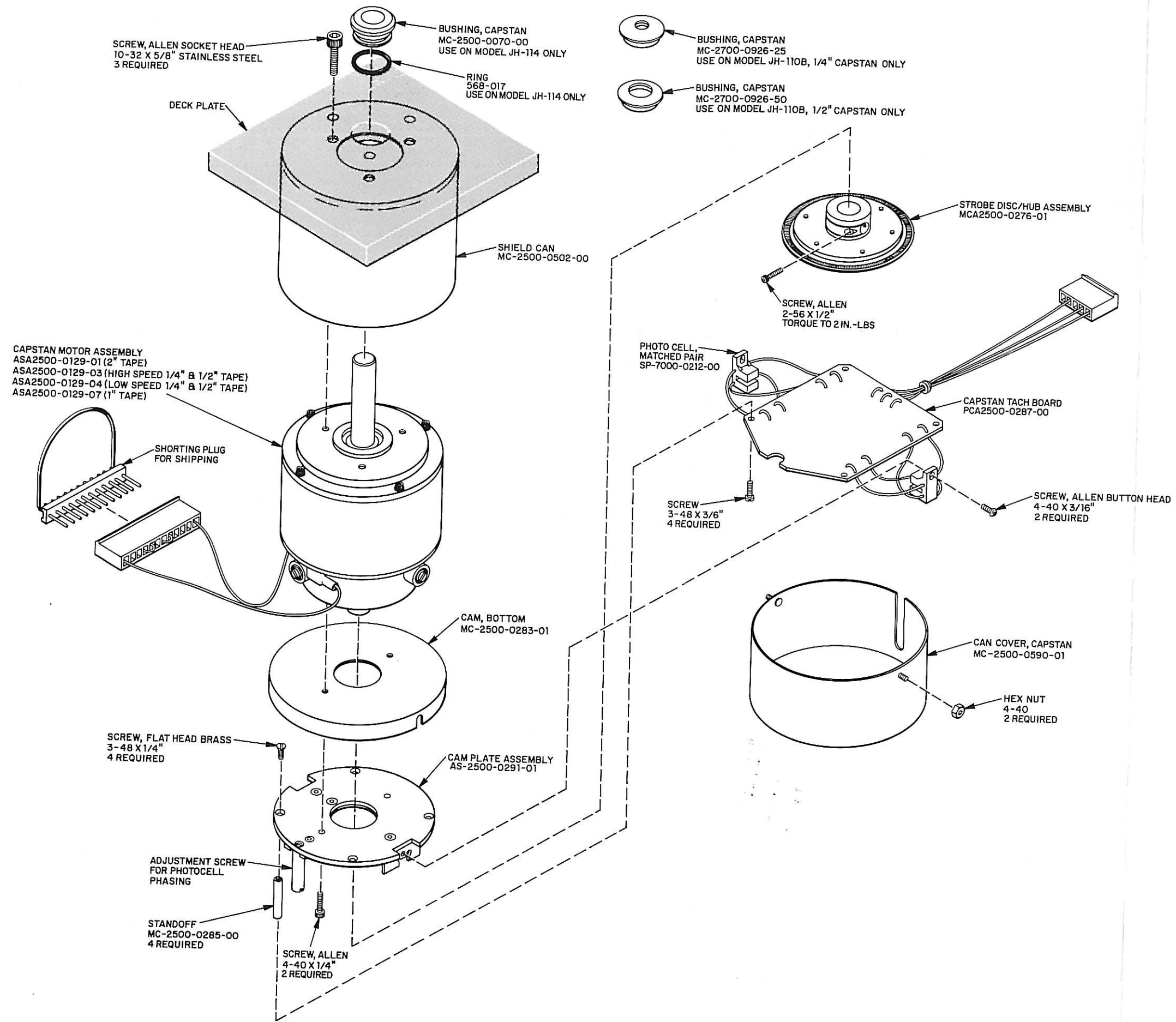

Capstan Motor and Tach Assembly
TW27D-48
Section 3 JH-110 SERIES

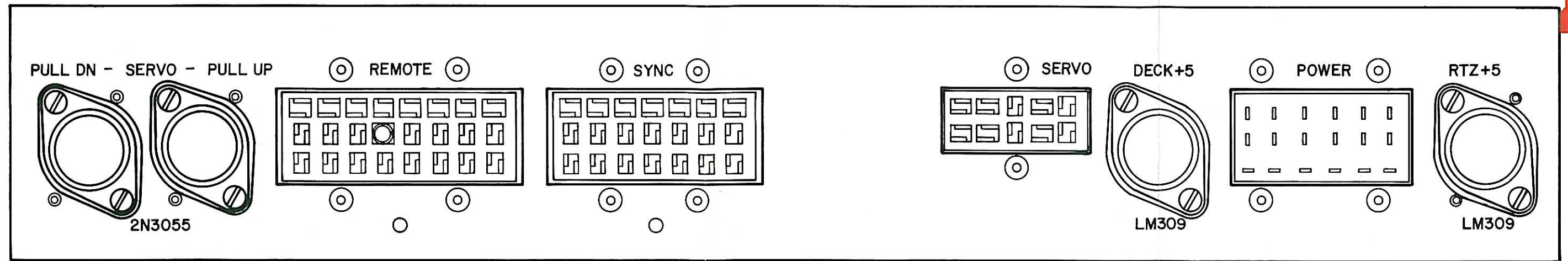

TW27C-34

REMOTE CONNECTOR		SYNC CONNECTOR		SERVO CONNECTOR		POWER CONNECTOR	
PIN	SIGNAL NAME	PIN	SIGNAL NAME	PIN	SIGNAL NAME	PIN	SIGNAL NAME
1	-15 vdc	1	NC	1	-15 vdc	1	Supply Motor LO
2	+22 vdc	2	STOP Lite	2	+15 vdc	2	Take-Up Motor LO
3	+15 vdc	3	PLAY Lite	3	<i>PLAY</i> NC	3	24 vac
4	RWD Lite	4	FWD Lite	4	Buffered Capstan Tach	4	+8 vdc
5	FWD Lite	5	RWD Lite	5	+8 vdc	5	+22 vdc
6	STOP Lite	6	REC Lite	6	EXT DC Control	6	-15 vdc
7	PLAY Lite	7	STOP CMD	7	Buffered 19.2 kHz	7	Ground
8	RECORD Lite	8	PLAY CMD	8	<i>Ground</i> NC	8	+15 vdc
9	Remote RWD	9	REC CMD	9	19.2 kHz Inject	9	Chassis Gnd
10	Remote FWD	10	COUNT	10	24 vac	10	Record Hold
11	Remote STOP	11	UP			11	30v Common
12	Remote PLAY	12	DOWN			12	Supply Motor HI (30 vdc)
13	Remote RECORD	13	Buffered Capstan Tach			13	RECORD Momentary
14	NC	14	+15 vdc			14	LO EQ
15	24 vac	15	Ground			15	MED EQ
16	RMVC Trigger	16	-15 vdc			16	HI EQ
17	RMVC Analog	17	19.2 kHz Inject			17	Supply AMP In
18	RMVC Lamp	18	A/L ENAB			18	Take-Up AMP In
19	Lifter Defeat	19	A/L CMD				
20	Ground	20	A/L Analog				
21	NC	21	A/L GND				
22	NC						
23	Remote Locate CMD						
24	Remote Reset CMD						

Rear Connector Pinouts
TW27C-34
JH-110 SERIES

Section 3

Control Panel Replacement Parts
 TW27C-35
 JH-110 Series

Section 3

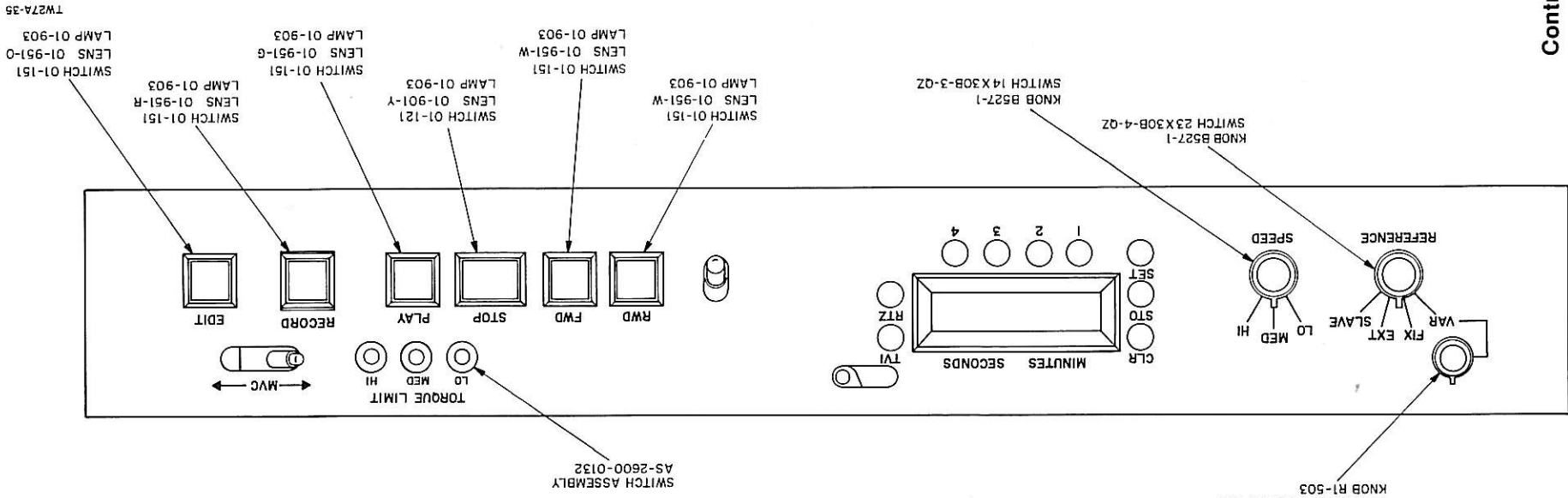

SECTION 4

RTZ III & AUTOLOCATOR III

4.1 General Description

4.1.1 RTZ III

The RTZ III is a microprocessor based position locator and velocity indicator. The microprocessor executes programs stored in its memory to perform the functions requested by the button switches on the display panel. Functions associated with each button switch are listed below.

TVI

(Tape Velocity Indicator)

Displays the tape velocity in inches per second while pressed. When released, display returns to position indication.

RTZ

(Return to Zero)

Locates tape to the position where zero was set on the display. The display is cleared to zero on power up and with the CLR button.

CLR

(Clear Display)

Clears the position display to zero on the RTZ III. Does not affect the position memories.

On the RTZ IIIM, this button clears the previously displayed band, expand, or lead out position. When pressed simultaneously with SET, clears the display to zero.

STO

(Store In Memory)

Allows storing the displayed position into one

of the location memories or lathe function memories.

1, 2, 3, and 4

(Autolocate Memories)

Locates the tape to the position stored in memory 1, 2, 3, or 4, respectively. Also used to store locations in memory and to set the display. To store the displayed location into memory, press and release STO, then press 1, 2, 3, or 4.

To set the display, press and hold SET, then press 1, 2, 3, or 4 to increment the digit directly above the button.

SET

(Set Display)

Allows presetting the display to any position, 0:00 to 99:59.

BND

(Band RTZ IIIM Only)

Displays the band function positions stored in memory. Position is flashed three times on the display. The next consecutive position is displayed each time the BND button is pressed.

To store the displayed position as a band position, press and release STO, then press BND.

XPD

(Expand, RTZ IIIM Only)

Displays the starting position followed by the ending position of the expand functions stored in memory. Each position is flashed three times on the display. The next consecutive expand

positions are flashed each time the XPD button is pressed.

To store expand positions into memory, press and release STO. Press XPD to store the displayed position as an expand start; release XPD to store the displayed position as an expand end.

OUT

(Lead Out, RTZ IIM Only)

Displays the end of record lead out position with three flashes. Only one OUT location can be stored in memory.

To store the displayed position as the lead out position, press and release STO, then press OUT.

4.1.2 Autolocator III

The Autolocator III is a microprocessor based position locator and velocity indicator. The microprocessor executes programs stored in its memory to perform the functions requested by the button switches on the front panel. The Autolocator III is available on the JH-110C-8 only. It mounts directly above the remote unit and interfaces to the tape transport via a thirty-five foot long cable harness.

Operating voltages for the autolocator come from the transport. The Autolocator III does not contain its own power supply, but does contain voltage regulators which produce +5vdc from the transport's +8vdc output. The transport's power supply also supplies $\pm 15\text{vdc}$ to the autolocator as required by the amplifiers on the Autolocator III.

The Autolocator III contains two four digit LED segment displays; one displays the current tape position, the other displays the desired locate position. Both displays indicate tape position in minutes and seconds of playback/record time normalized to the standard (fixed) speeds.

A numeric keyboard enters digits into the locate position display. With each key strike the digits in the display shift to the left, entering the new digit in the rightmost column. If, by mistake, a number greater than 59 is punched into the seconds column, the display will automatically convert the time into minutes and seconds. For example, if 78 seconds is entered into the locate position

display, it will be converted to 1 minute 18 seconds prior to the execution of any function.

Once a time (or position) is entered into the locate position display the transport can autolocate to that position simply by pressing the LOC button.

At any time while the transport is in stop, play, or record mode the current tape position can be loaded into a locate position memory. Pressing \rightarrow (shift right), STO (store), and any of the numeric keys stores the time from the tape position display into the corresponding locate memory. These positions can later be recalled and displayed in the locate position display by pressing RCL and the respective numeric key. The LOC button will then locate the transport to the position retrieved from memory.

The locate memories can be pre-loaded with any position by entering the time into the locate position display via the numeric keyboard. From the located position display the time is entered into the memory with the STO and numeric key sequence.

The position memory can be pre-loaded with any position by first entering the time into the locate position display via the numeric keyboard. Then, the \leftarrow (shift left) button, is used to shift the locate position into the tape position display, redefining the current tape position.

The \rightarrow (shift right) button, can be used to temporarily store tape positions into the locate position display for future locates or to mark the position for convenience.

The repeat function yo-yos the transport between the positions stored in memories 8 and 9. The transport, after pressing REP, autolocates to position 8, drops into play mode, plays back up to position 9, rewinds to position 8, and drops into play mode again. This process will continue indefinitely. It is cancelled by pressing the transport STOP, RWD or FWD button or the autolocator's LOC button.

For the repeat function to work, the tape position stored in memory 9 must be greater than the tape position stored in memory 8. If this is not the case, and the REP button is pressed, the transport will autolocate to the position stored in memory 8 and stop.

The AutoLocator III also performs velocity control and velocity display functions. Pressing and holding the TVI (Tape Velocity Indicator) button displays the tape speed in the tape position display. Releasing the TVI button returns the autolocator to the position display mode.

If the tape transport's reference select switch is in the external (EXT) position, the MODE switch toggles between the fixed crystal speed reference and the variable dc reference level to the VCO. LEDs on the front panel indicate whether the fixed reference or the variable reference is selected.

In the variable mode the SPEED potentiometer on the autolocator controls the pitch in the same manner as the SPEED potentiometer on the transport deck when the transport is in VAR reference.

In variable reference mode, the TVI switch displays both the tape velocity in the tape position display and the pitch change in the locate position display. Pitch change is indicated in terms of semitones of the enharmonic scale. Only multiples of $\frac{1}{4}$ semitones are displayed. The locate position display is blank unless the tape velocity is within ± 0.03 ips of a multiple of $\frac{1}{4}$ semitone pitch change from the standard speed.

4.2 Hardware Functional Description

The hardware for the autolocators is mounted on two printed circuit boards; a processor board and a display board. The processor boards for the RTZ III and the AutoLocator III are the same, PCA2500-0611. However, the two systems use different display boards. Even though both systems use the same processor boards, the processor boards are not interchangeable. The AutoLocator requires a different program ROM to accommodate the additional functions and to handle the more massive tape reels. An additional processor plug-on board is used only on the JH-110M machine to deliver interface outputs to the disc-cutting lathe. It is not used on the other recorders.

The basic operation of the hardware and software for all JH-110B transports is similar. The major difference between the standard RTZ III and the eight track's AutoLocator III is that the AutoLocator's display board contains circuitry for two multiplexed displays and for additional control buttons. The AutoLocator III also contains circuitry for tape speed control. These are not part of the microprocessor, and function separately from any of the microprocessor circuitry.

Refer to the block diagrams of the RTZ III and the AutoLocator III, figures 4.1A and 4.1B. The microprocessor, its memory and I/O ports are located on the Processor Board. The display and display encoders or controllers are located on the Display Board. Schematics for these boards are found at the end of this section.

The microprocessor communicates with its memory and I/O ports via the address and data bus. This bus is multiplexed, that is, it is used for both address and data. Addresses arrive on the bus first, followed by data. An address latch stores the bus address low order bits (A0 — A7) while the data is asserted on the bus. The high order bus address bits (A8 — A12) are not latched; these lines are not multiplexed.

Control signals from the microprocessor allow the memory or I/O ports to assert information onto, or receive information from the address and data bus. To fetch an address or an instruction from memory, the microprocessor asserts an address onto the bus and latches the address in the address latch. The memory then places the contents of that location on the bus for the processor to read. The microprocessor reads and writes data from and to the I/O ports using the command signals \overline{RD} , \overline{WR} , and \overline{IOM} .

Data from the I/O ports is sent to the display encoders to operate the LED display and to the D to A converter to operate the reel motors. The I/O ports receive speed and direction information from the transport and commands from the display buttons.

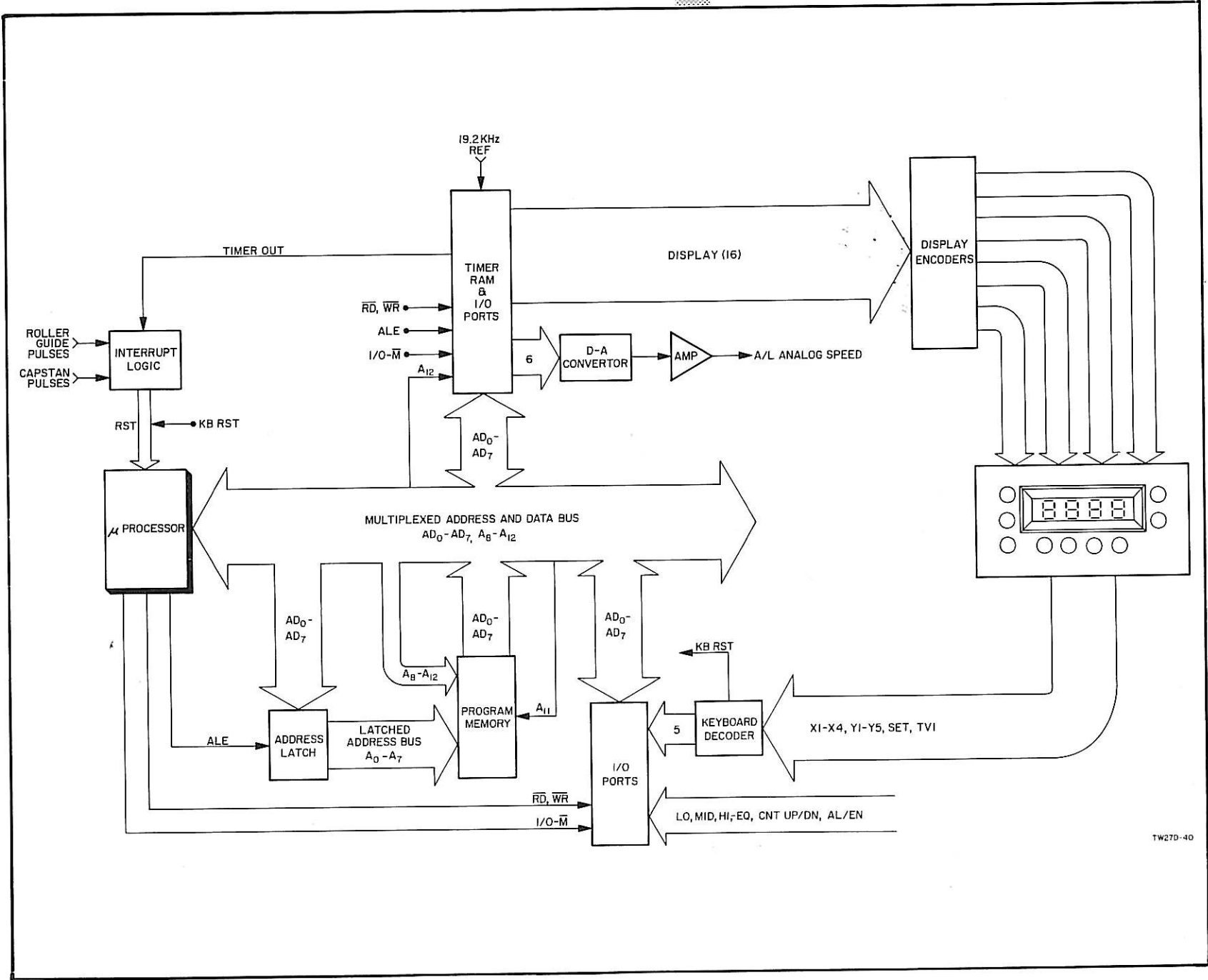
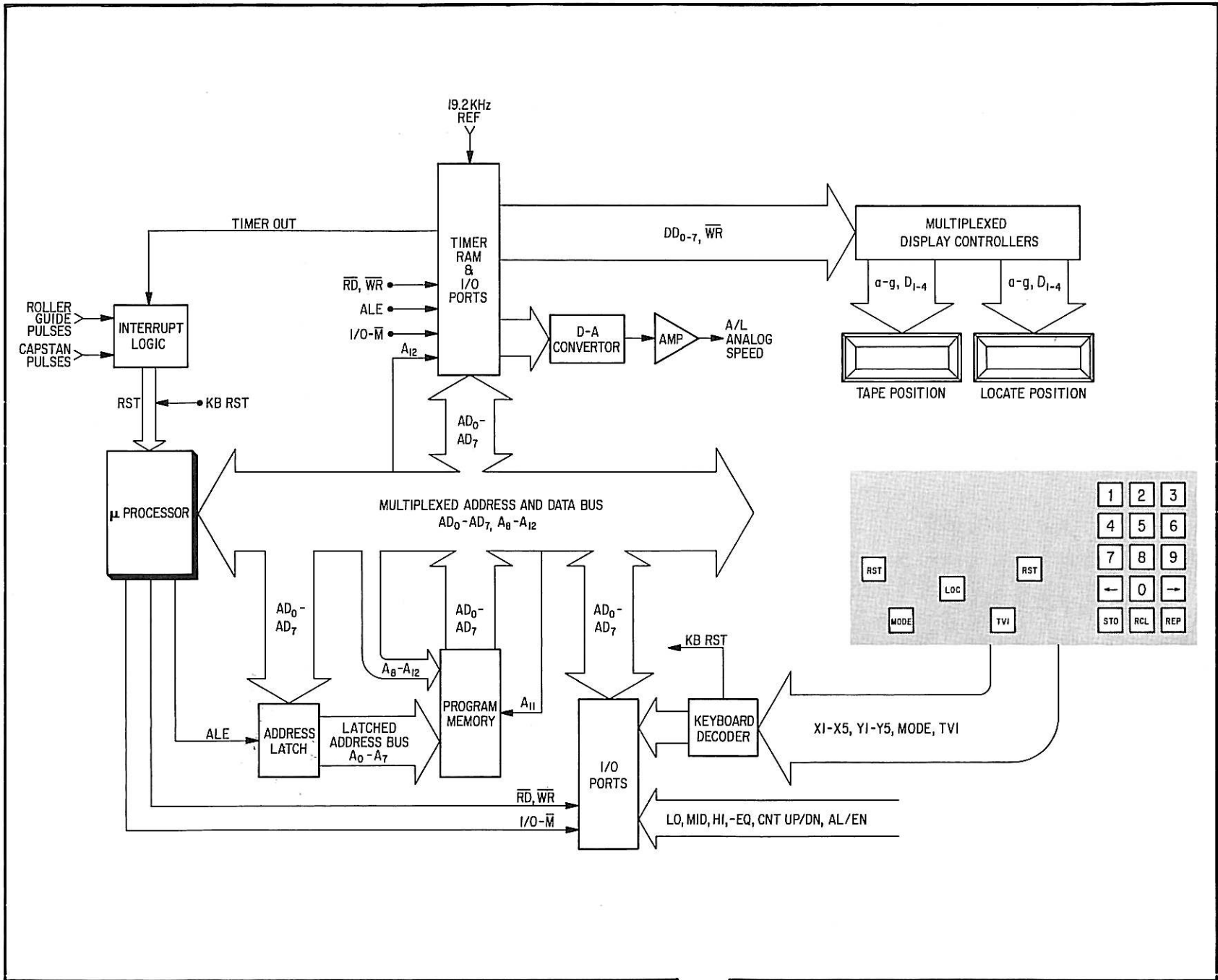

Figure 4-1A
RTZ III Block Diagram

Figure 4-1B
Autolocator III Block Diagram



4.3 Program Description

The program which determines the operation of the microprocessor is stored in the program memory, a MOS PROM chip. The stored program is organized into a background loop, subroutines which perform certain tasks, and interrupt service routines which handle the interrupts. Subroutines, called from the background loop, calculate velocities, distances, and store data in temporary memory. The interrupt service routines respond to the switches on the display panel, and pulses from the tape roller guide and the capstan tachometer.

The programming cannot be altered. The RTZ III is not user programmable, the instructions and the structure of the program are fixed.

From power up, the processor executes instructions in the background loop. A simplified flowchart of the background loop is given in Figure 4-2. In this loop, the processor reads speed information, poles various flags, and updates the display. The speed select switch information is used to normalize the display so that it shows the correct position/time for the tape speed selected. If any flags are set, the program jumps to the appropriate subroutine to perform the requested task. When the subroutine function is completed the program returns to the background loop. At any time an interrupt will cause the program to vector to an interrupt service routine. After servicing the interrupt the program returns to the place in the background loop or subroutine where the interrupt occurred.

As an example, assume that while the processor is executing instructions in the background loop, the TVI switch is pressed setting the TVI flag. The program tests the flag and jumps to the TVI subroutine. A timer is set up and the capstan tachometer pulses are allowed to interrupt the processor through the interrupt logic. Every other capstan pulse causes a jump to the capstan interrupt routine which counts these pulses to determine the tape velocity. When the timer times out the velocity is calculated, displayed, and the program returns to the background loop.

Interrupts are also generated by the display button switches and the roller guide pulses. Each time the microprocessor receives a roller guide

pulse it vectors to the roller guide interrupt service routine. This routine updates, that is, increments or decrements, the display count and then returns to the background loop or subroutine where the interrupt occurred.

Pressing a button switch generates an interrupt which causes a jump to the switch interrupt service routine. The switch's numerical value from the keyboard decoder determines which subroutine is jumped to next. The interrupt routine reads the switch value and calls the corresponding subroutine. Once the subroutine performs the task requested by the switch, the program returns to the background loop.

4.4 RTZ IIIM Lathe Control Outputs

4.4.1 Scully Lathe

During playback, when the tape position matches the stored position, the appropriate function is output to the record lathe. The BAND function consists of turning on an open-collector transistor for $\frac{1}{4}$ sec. The L-OUT function consists of turning on the same open-collector transistor for $\frac{1}{4}$ sec., off for $\frac{1}{4}$ sec., and back on for $\frac{1}{4}$ sec. The EXPAND transistor is simply turned on at the starting position stored, and off at the ending position stored.

4.4.2 Neumann Lathe

During playback, when the tape position matches the stored position, the appropriate function is output to the record lathe. The BAND function consists of turning on an open-collector transistor for $\frac{1}{4}$ sec. The L-OUT function consists of turning on another open-collector transistor for $\frac{1}{4}$ sec. The EXPAND transistor is simply turned on at the starting position stored, and off at the ending position stored.

4.4.3 Interfacing Information

Open-collector outputs are provided, as shown in Figure 4-3, in order to provide versatility in interfacing to various lathe machines. The outputs are capable of sinking up to 200 ma and can withstand 40V collector to emitter. A four pin Molex connector is used for J10, which is located on the plug-on module on the RTZ III board.

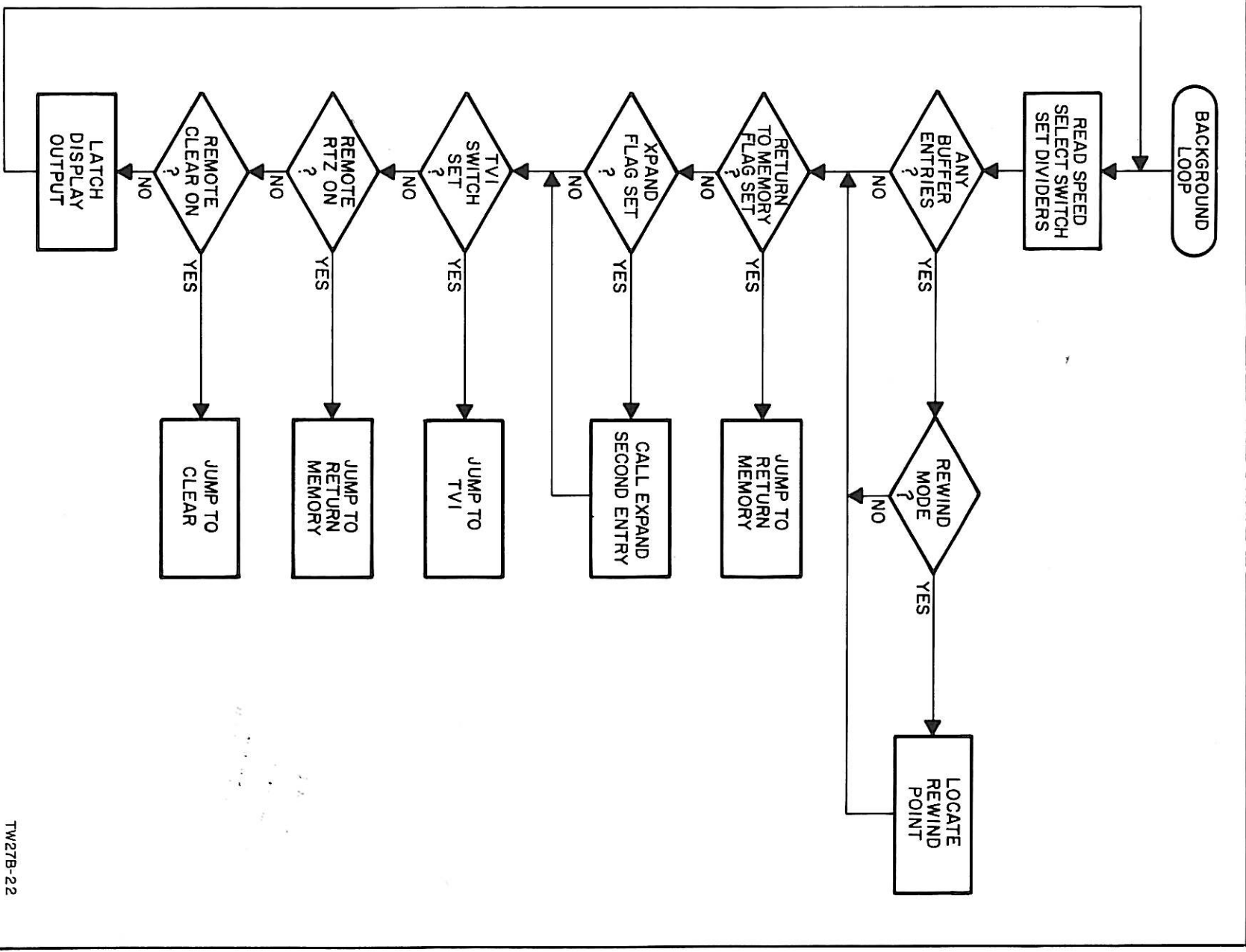

TW27B-22

Figure 4-2
Background Loop Flowchart

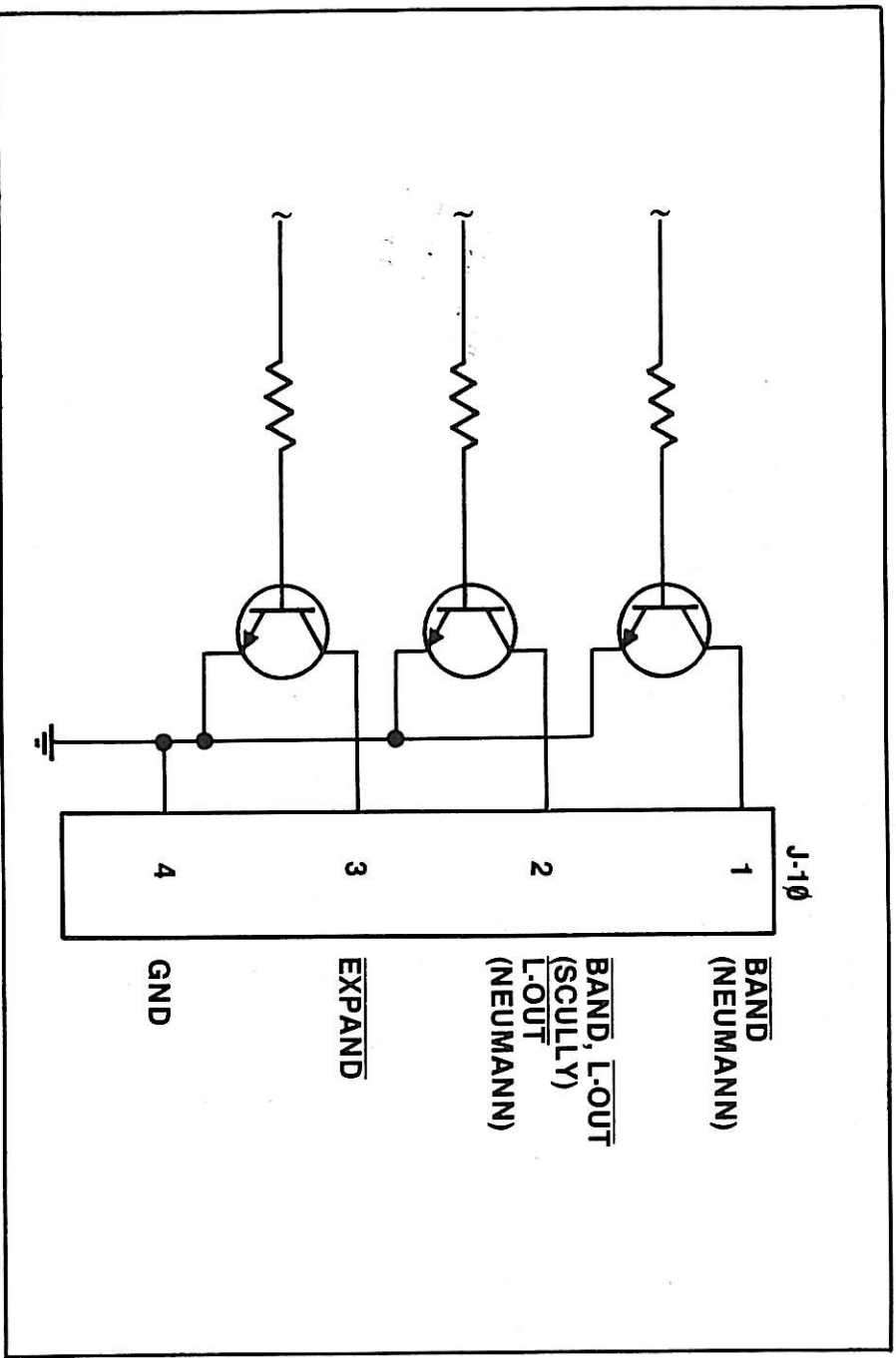

4

Figure 4-3
Mastering Interface

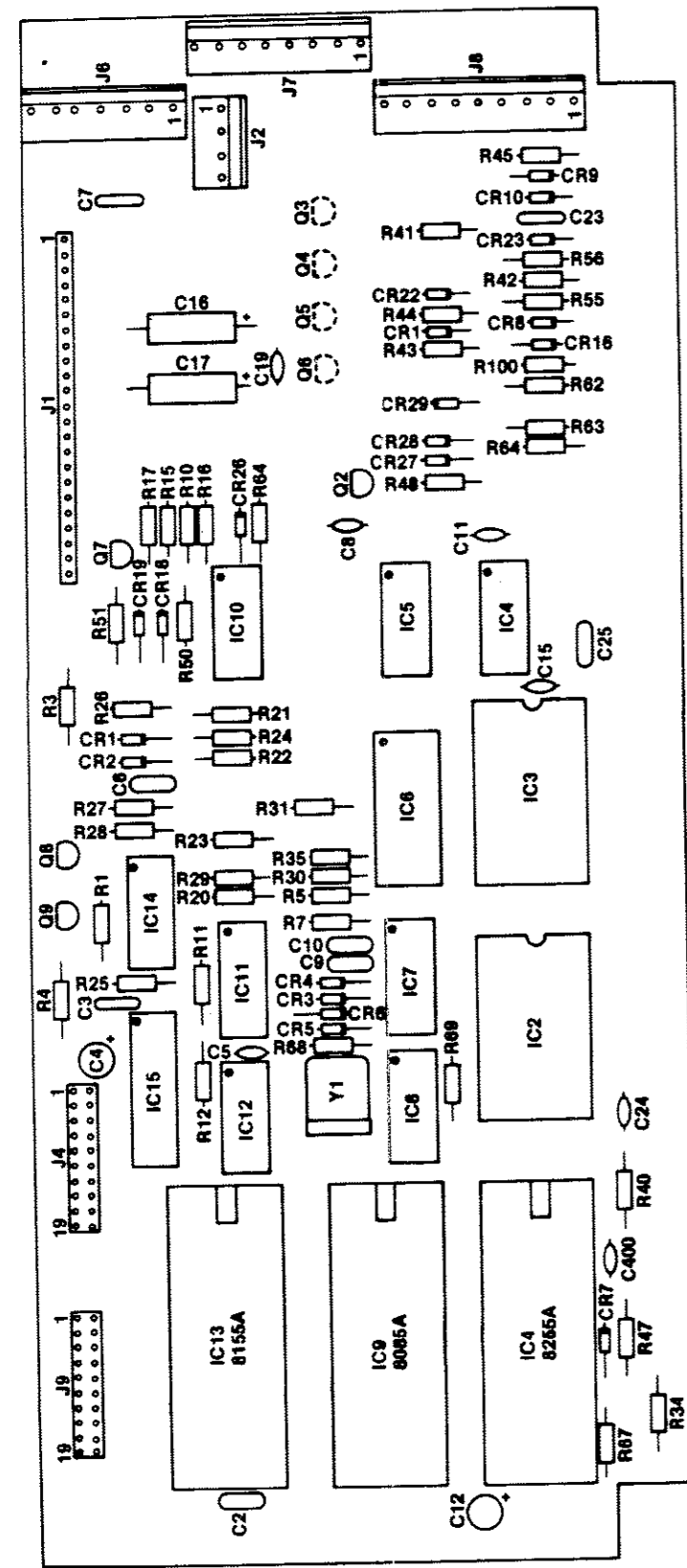

PROCESSOR BOARD PCA2500-0639

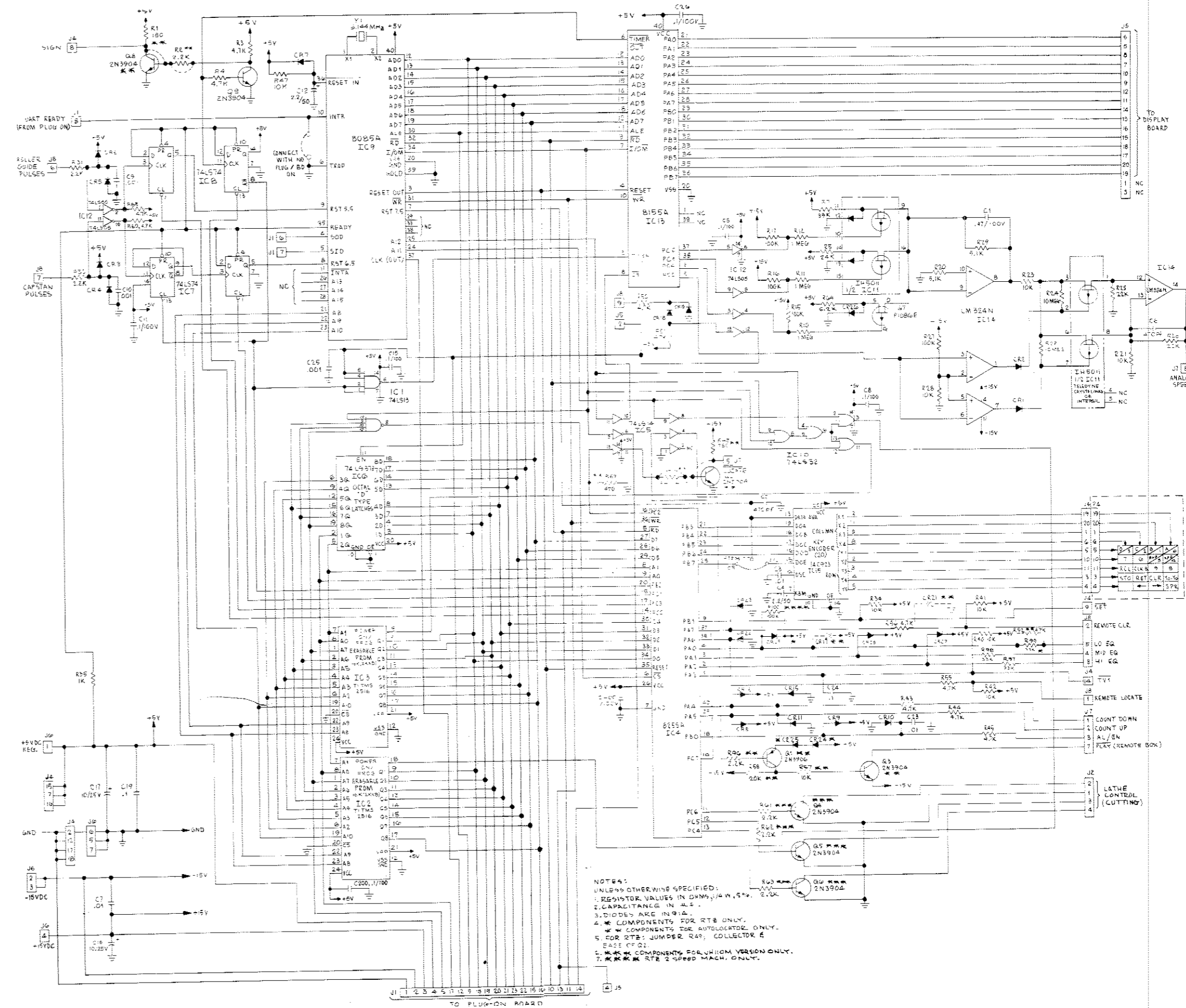

- NOTES:
- UNLESS OTHERWISE SPECIFIED:
 - RESISTOR VALUES IN OHMS, IN Ω , IN $k\Omega$, IN $M\Omega$.
 - CAPACITANCE IN μF .
 - DODGES MAKE IN Q1A.
 - * COMPONENTS FOR RTE ONLY.
 - COMPONENTS FOR AUTOLISTED ONLY.
 - FOR DTS: JUMPER Q29, COLLECTOR & BASE OF Q1.
 - COMPONENTS FOR LITHIUM VERSION ONLY.
 - *** COMPONENTS FOR 2 SPEED MACH. ONLY.

PROMS

MCI uses the following identification system on all PROMS. As there are several versions and rev. levels available, please take note of the following:

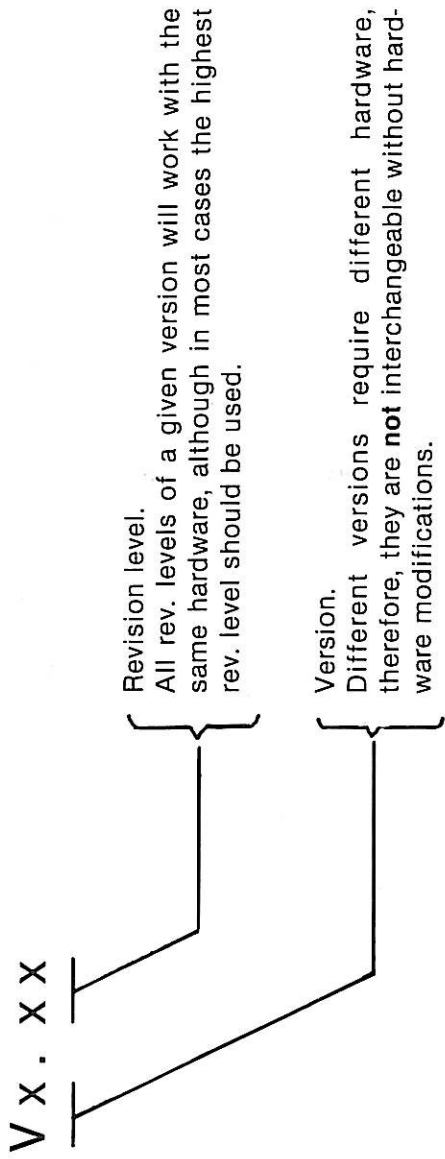

The following PROMS are currently in use in the RTZ III and RTZ III/M.

V1.0	RTZ III (for 1/4" tape)
V1.1	RTZ III (for 1/2" and 1" tape)
V2.0	RTZ III/M (Scully Lathe, Capps VP and VD)
V3.0	RTZ III/M (Neuman Lathe, Capps II)

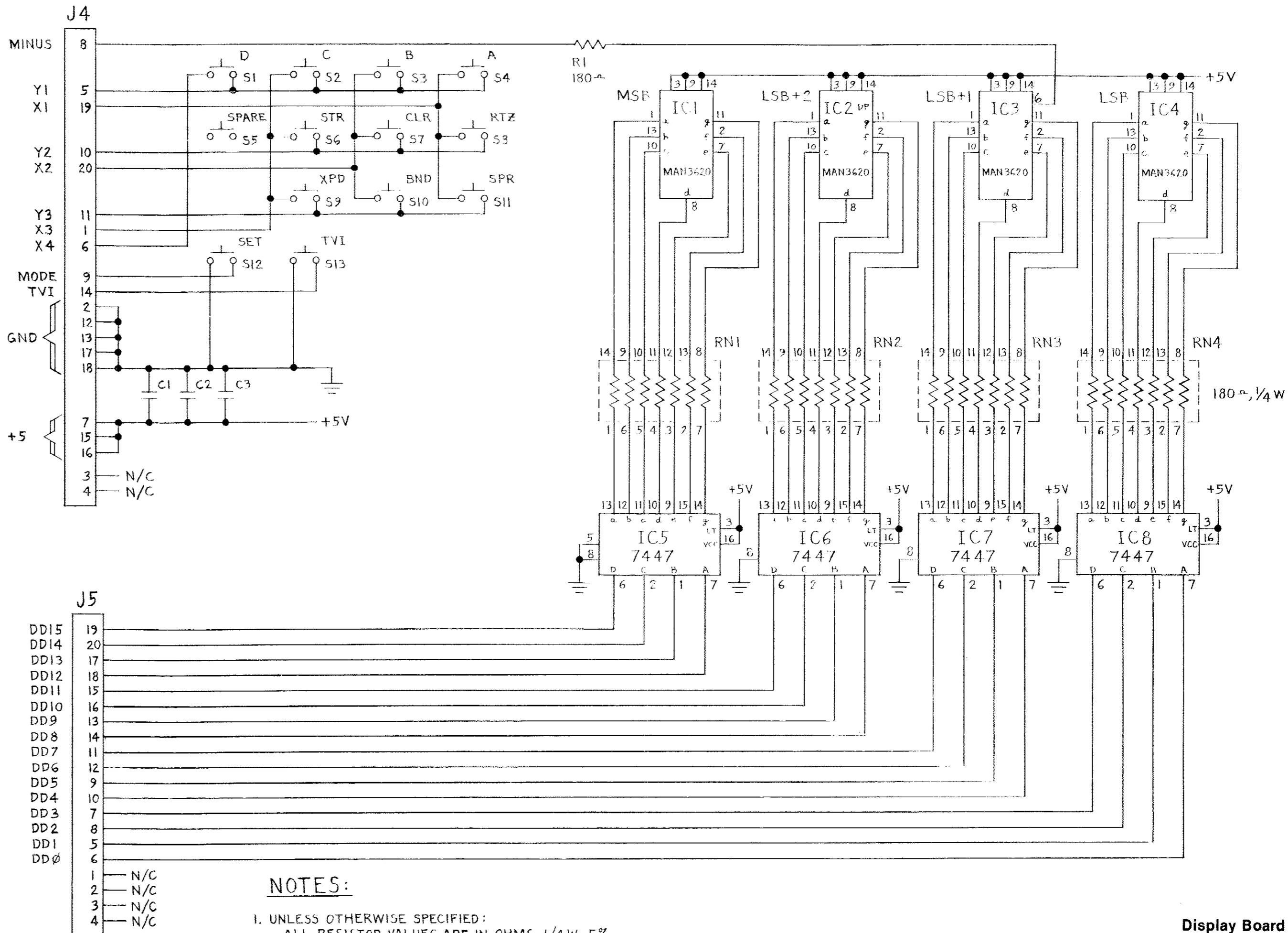
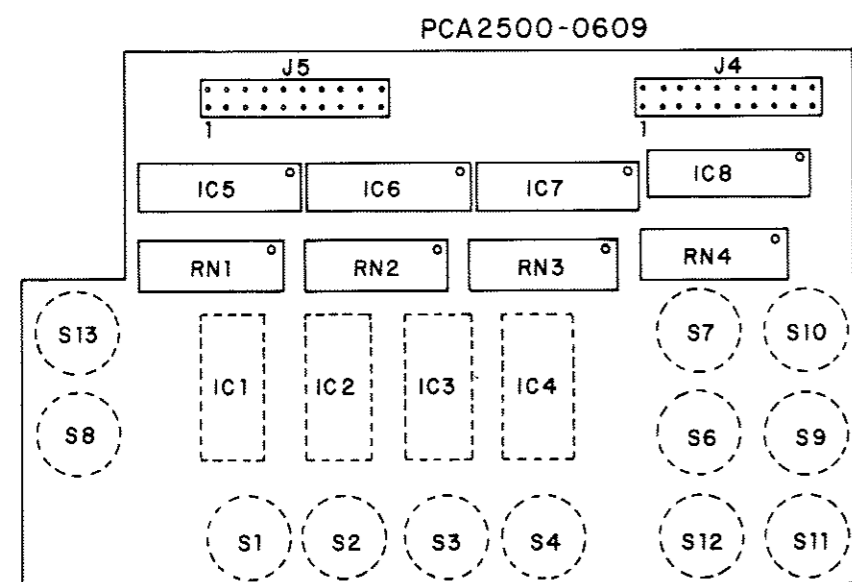

PARTS LIST

DISPLAY BOARD P/N 2500C0609-00

	QUANTITY	RTZ III	RTZ III/M
14 PIN DIP SOCKET	4		4
20 PIN DIP HEADER	2		2
SPACER	3		3
GRAY SWITCH	4		7
RED	1		1
BLUE	1		1
YELLOW	1		1
WHITE	1		1
BLACK	1		1

MP-DIP-SKT	4		4
20P DIP-HDR	2		2
MC-2600-0298-00	3		3
502-010-009	4		7
502-010-007	1		1
502-010-008	1		1
502-010-002	1		1
502-010-003	1		1
502-010-001	1		1

PROCESSOR BOARD P/N 2500E0611-00

MCI PROGRAMMED ROM

P/N RTZ III (See PROMS)	1		1
----------------------------	---	--	---

CRYSTAL 6.144MHZ
MICROPROCESSOR
20 PIN DIP HEADER
40 PIN DIP SOCKET
24 PIN DIP SOCKET

BMP61	1		1
8085A	1		1
20P-DIP-HDR	2		2
40P-DIP-SKT	3		3
24P-DIP-SKT	1		1

PROCESSOR PLUG ON BOARD P/N 2500C0625-00

(RTZ III/M ONLY)

MCI PROGRAMMED ROM

P/N RTZ III/M (See PROMS)	1		1
------------------------------	---	--	---

RTZ III & III/M — JH-110B

DATA INTERCONNECT HARNESS
MATRIX HARNESS
STANDOFF
BEZEL

WD2500-0617-01	1		1
WD2500-0617-02	1		4
SP7100-0047-00	4		1
22463R-04	1		1

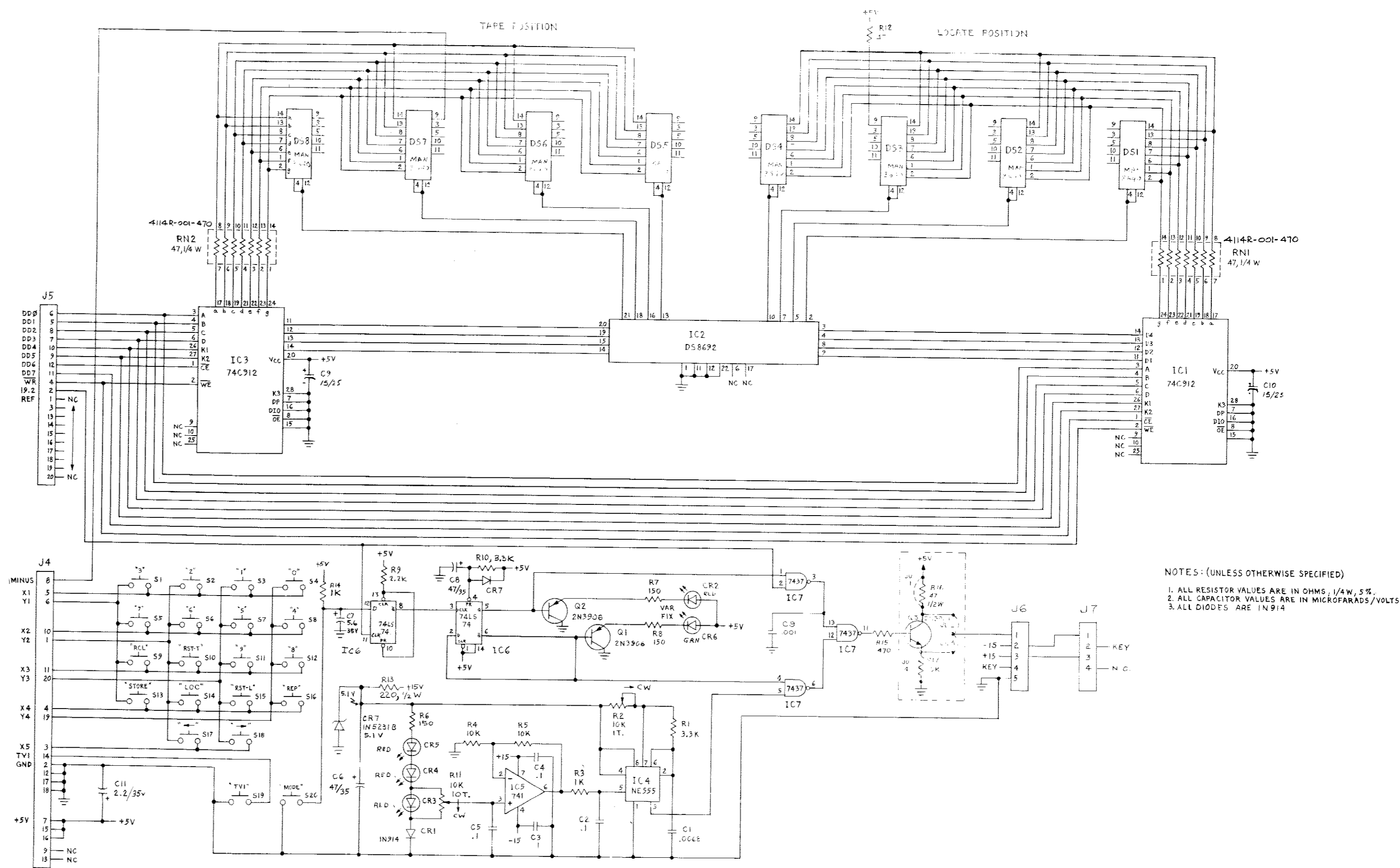
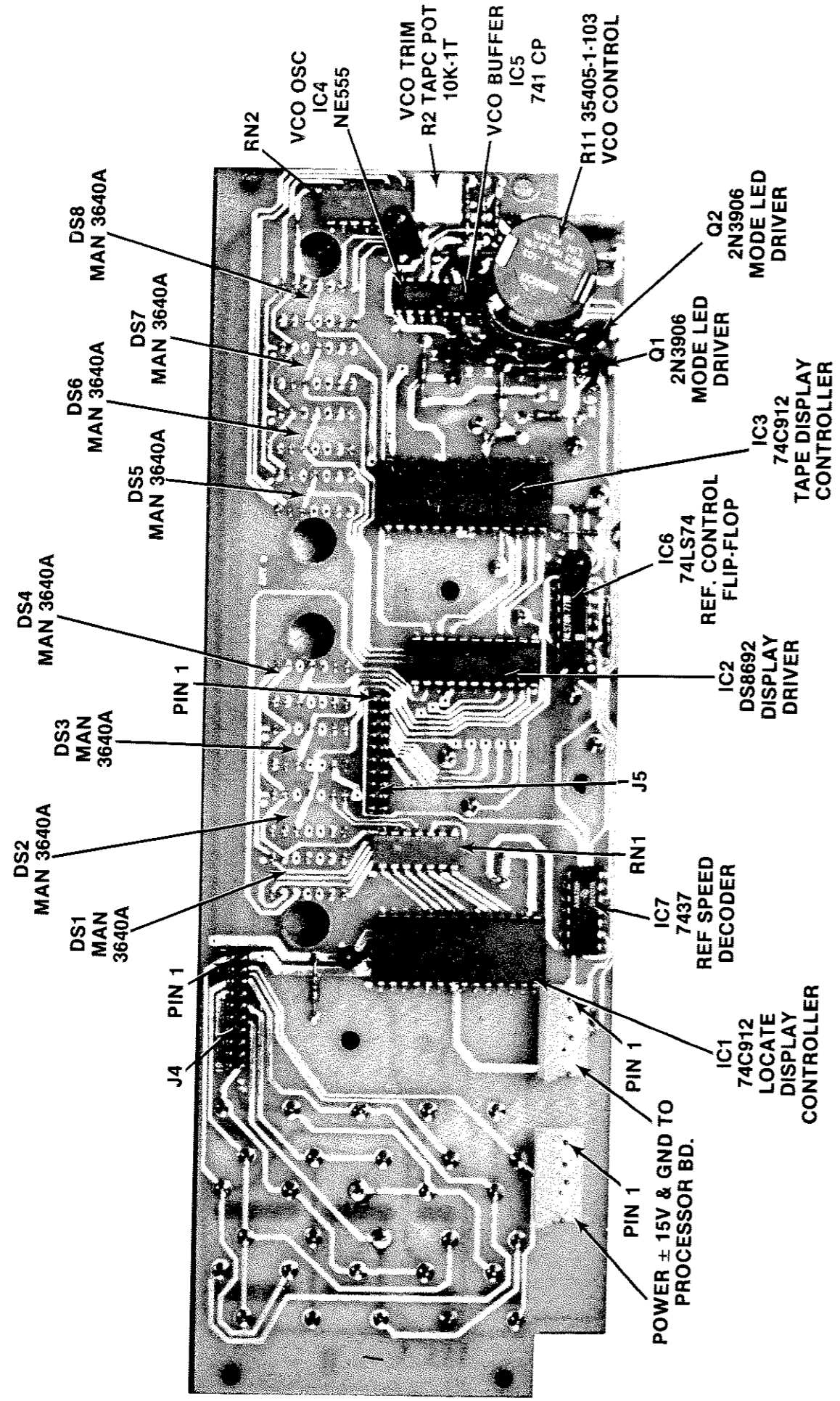

NOTES: (UNLESS OTHERWISE SPECIFIED)
1. ALL RESISTOR VALUES ARE IN OHMS, 1/4W, 5%.
2. ALL CAPACITOR VALUES ARE IN MICROFARADS/VOLTS.
3. ALL DIODES ARE 1N914

PARTS LIST — DISPLAY BOARD

PART NUMBER	DESCRIPTION	QUAN.	DESIGNATOR
PCA2500-0610-00	PCA, DISPLAY BD A/L III	1	
09-65-1021	MOLEX 2PIN LOCK 3/4"	1	
09-65-1051	MOLEX 5PIN LOCK 3/4"	1	
1-87227-0	20PIN DOUBLE POST DIP	2	
1.0-KOHM5%-1/4 W	CARBON FILM RESISTOR	2	R3, R10
10--KOHM5%-1/4 W	CARBON FILM RESISTOR	2	R4, R5
150--OHM5%-1/4 W	CARBON FILM RESISTOR	2	R7, R8
180--OHM5%-1/4 W	CARBON FILM RESISTOR	1	R6
1N5231B-5.1V	DIODE, ZENER-SILCN 5.1V-5	1	CR7
1N914	DIODE, SIGNAL-SILCN GLASS	2	CR1, CR7
22--KOHM5%-1/4 W	CARBON FILM RESISTOR	1	R9
220--OHM5%-1/2 W	CARBON FILM RESISTOR	1	R13
22P-DIP-SKT	DIP SKT AUGAT 522-AG-11D	1	
28P-DIP-SKT	DIP SKT AUGAT 528-AG-11D	2	
2:2MF50V-CLYRL	LYTIC RAD/LD SEALED (LL)	1	C11
2N3906	TRANSISTOR	2	Q1, Q2
3.3-KOHM5%-1/4 W	CARBON FILM RESISTOR	1	R1
3540S-1-103	10K 10TURN LIN PANEL MOUNT	1	R11
4114R-001-470	47 OHM 14P-DIP BOURN DIP	2	RN1, RN2
47--OHM5%-1/4 W	CARBON FILM RESISTOR	1	R12
47MF35V-CLYRL	LYTIC RAD/LD SEALED (GP)	2	C6, C8
741CP	OP AMP	1	IC5
7437	QUAD 2-IN NAND BUFFER	1	IC7
74C912	IC DISPLAY CONTROL NATL	2	IC1, IC3
74LS74	IC DUAL D FLIP FLOP	1	IC6
:0068MF400V-CMY	MYLAR CAPACITOR MEPCO	1	C1

PART NUMBER	DESCRIPTION	QUAN.	DESIGNATOR
:1MF100V-CCD20	CERAMIC DISC CAPACITOR	7	C2, 3, 4, 5, 7, 9, 10
DS8692	IC DISPLAY DRIVER NAT'L	1	IC2
MAN-3640A	DISPLAY MONSANTO	8	DS1 - DS8
MC-6000-0404-01	SW D-6 "1"	1	S3
MC-6000-0404-02	SW D-6 "2"	1	S2
MC-6000-0404-03	SW D-6 "3"	1	S1
MC-6000-0404-04	SW D-6 "4"	1	S8
MC-6000-0404-05	SW D-6 "5"	1	S7
MC-6000-0404-06	SW D-6 "6"	1	S6
MC-6000-0404-07	SW D-6 "7"	1	S5
MC-6000-0404-08	SW D-6 "8"	1	S12
MC-6000-0404-09	SW D-6 "9"	1	S11
MC-6000-0404-10	SW D-6 "0"	1	S4
MC-6000-0404-13	SW D-6 "STO"	1	S13
MC-6000-0404-14	SW D-6 "RCL"	1	S9
MC-6000-0404-15	SW D-6 "REP"	1	S16
MC-6000-0404-16	SW D-6 "RST"	2	S10, S15
MC-6000-0404-17	SW D-6 "LOC"	1	S14
MC-6000-0404-18	SW D-6 "TVI"	1	S19
MC-6000-0404-19	SW D-6 "MODE"	1	S20
MC-6000-0404-20	SW D-6 "→"	1	S17
MC-6000-0404-21	SW D-6 "←"	1	S18
MV5075C	LED RED MONSANTO	1	CR2, 3, 4, 5
NE555	PRECISION TIMER	1	IC4
TAPCPOT10K-1T	BU3386F-1-103/BK72MR10K	1	R2
XC209G	LED GREEN	1	CR6

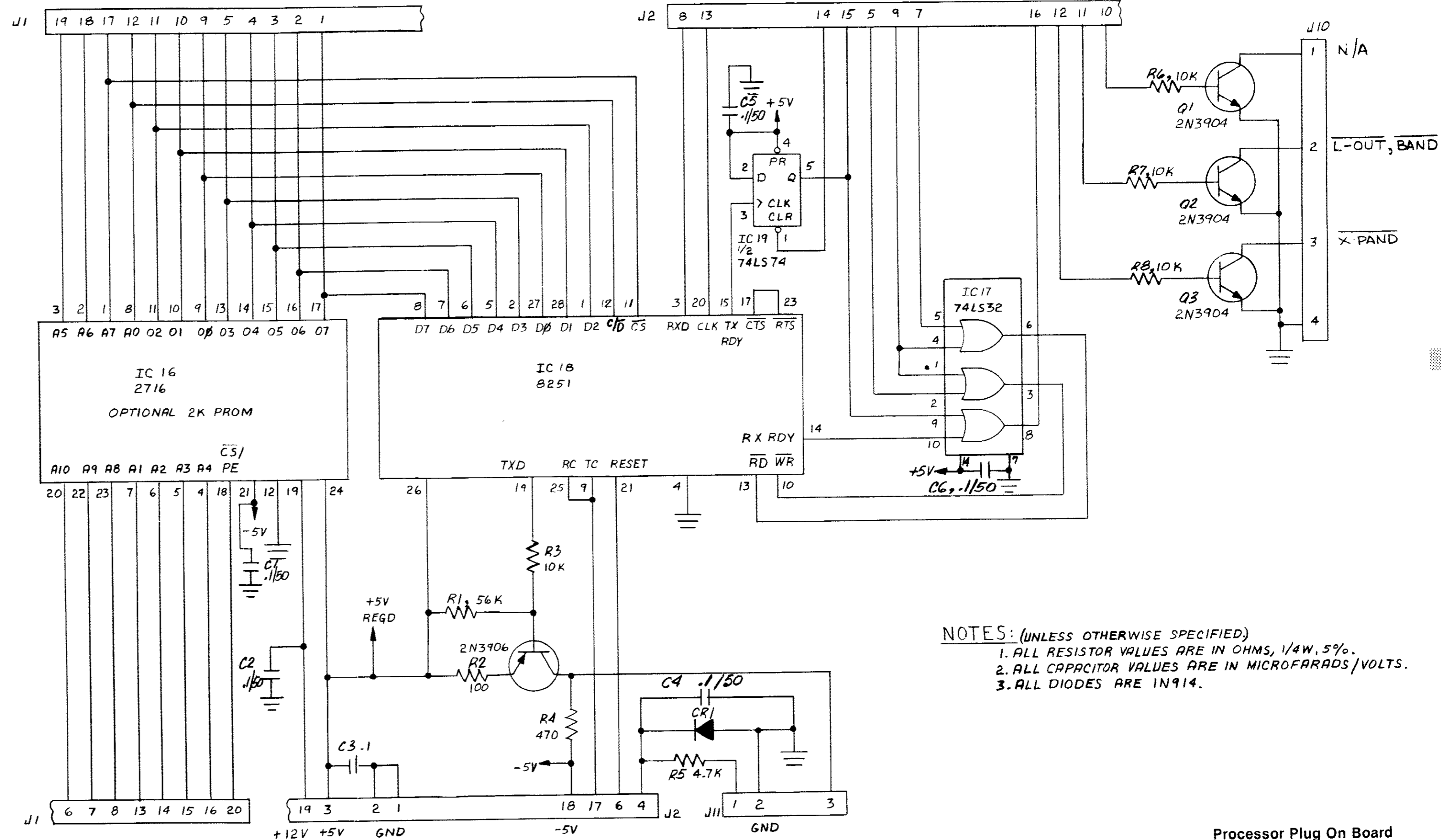
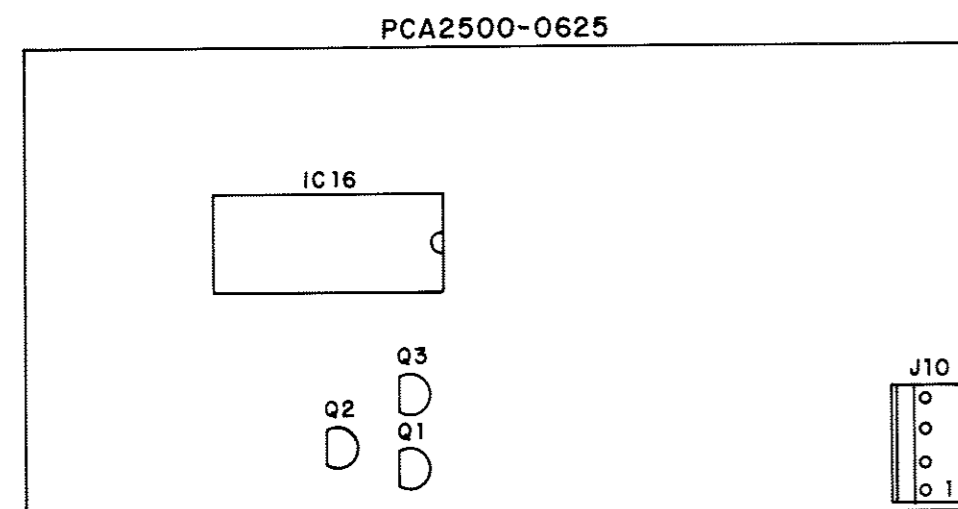

- NOTES: (UNLESS OTHERWISE SPECIFIED)
1. ALL RESISTOR VALUES ARE IN OHMS, 1/4W, 5%.
 2. ALL CAPACITOR VALUES ARE IN MICROFARADS/VOLTS.
 3. ALL DIODES ARE 1N914.

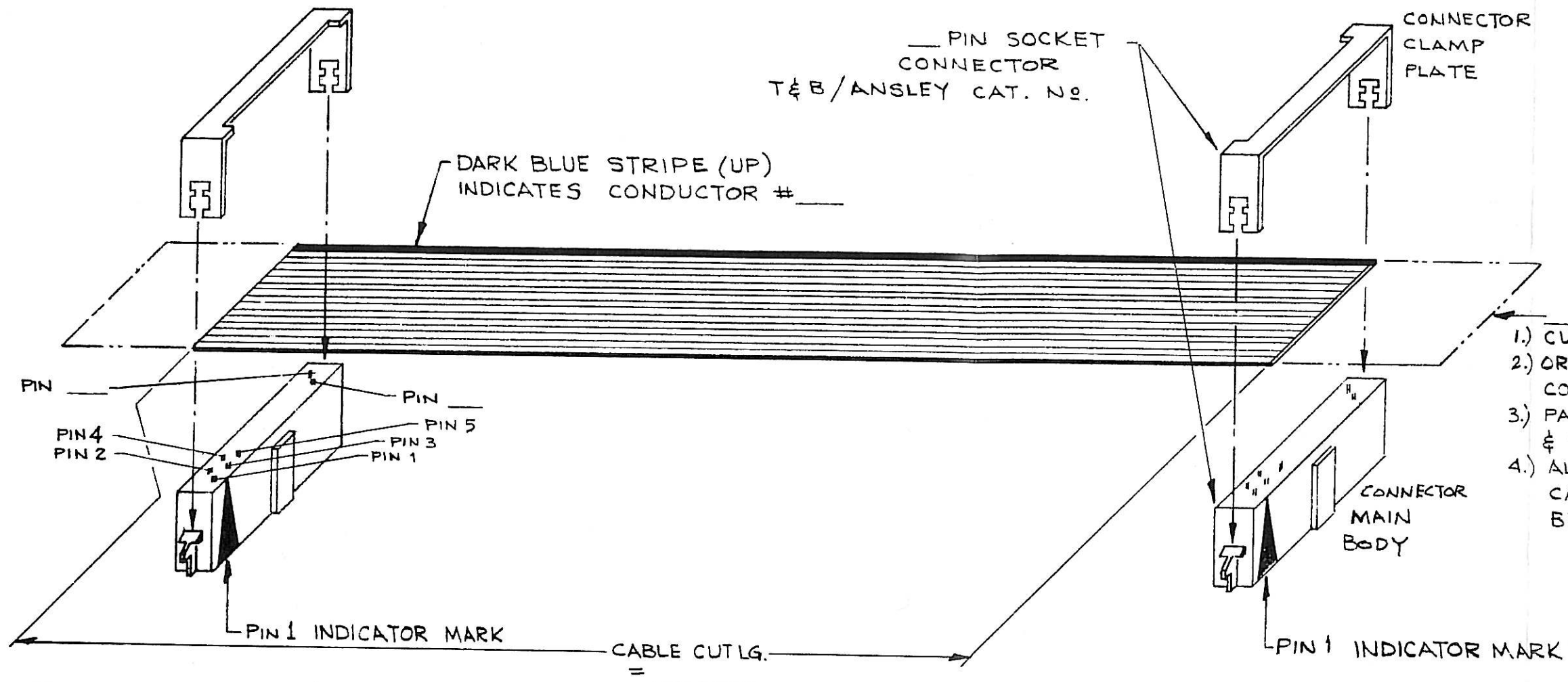

- 1.) CUT TO LENGTH
- 2.) ORIENT CONN. CLAMP PLATE & CONN. MAIN BODY AS SHOWN.
- 3.) PASS CABLE BETWEEN CLAMP PLATE & MAIN BODY
- 4.) ALIGN CABLE TO CONN. & CRIMP. CABLE SHOULD BE .010 to .040 BEYOND FLUSH TO CONNECTOR.

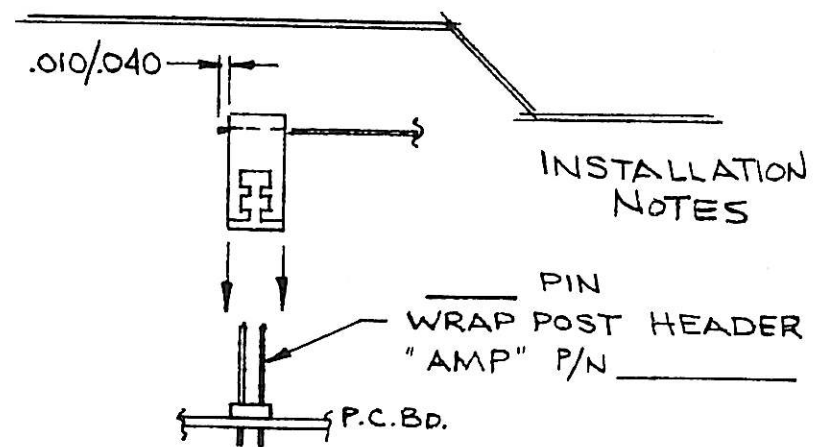

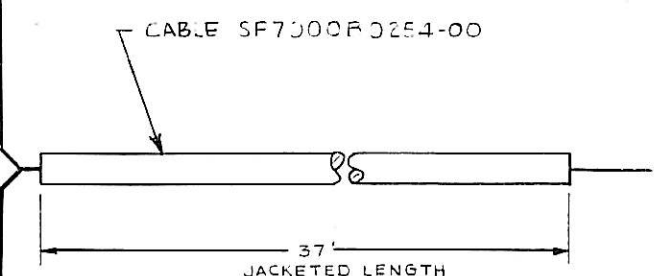
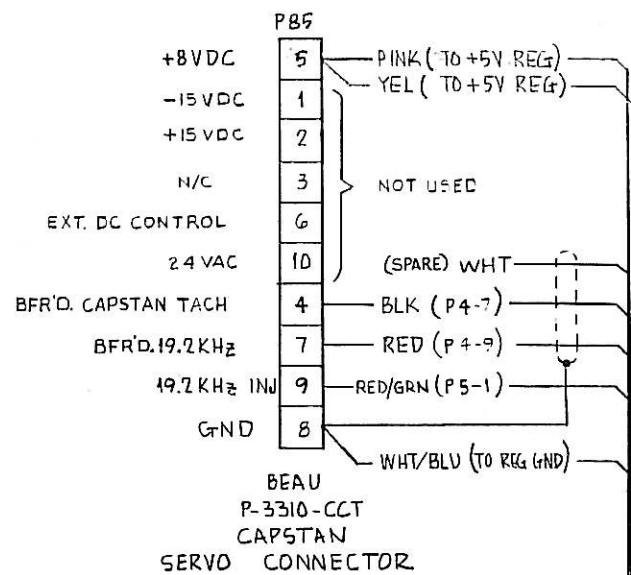

TRIM WIRE BUNDLE TO 12" FREE LENGTH

RED/BLK (P88-1) TO WDA 2700-0940-00 MOLEX P1-10

TRIM WIRE TO 16", AND TERMINATE IN SINGLE MOLEX PIN.

TRIM WIRE BUNDLE TO 18" FREE LENGTH

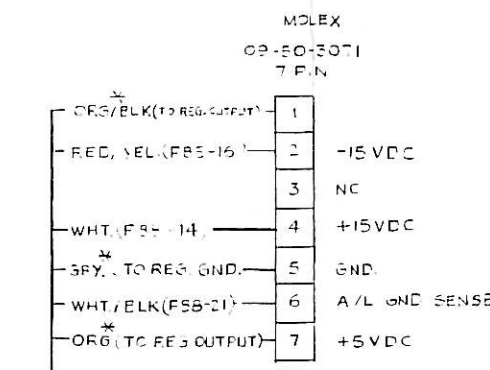
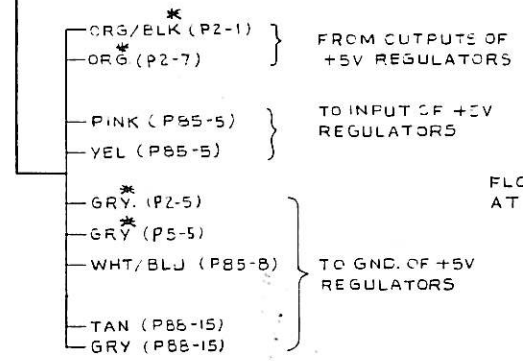

TO J6
A/L-3 PROCESSOR BD.
PCA 2500-0611
OR PCA 2500-0639

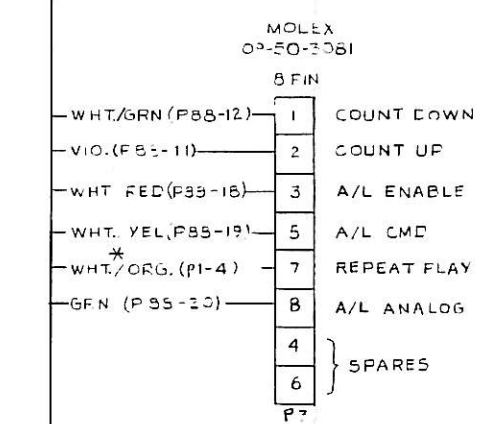

TO J7
A/L-3 PROCESSOR BD.
PCA 2500-0611
OR PCA 2500-0639

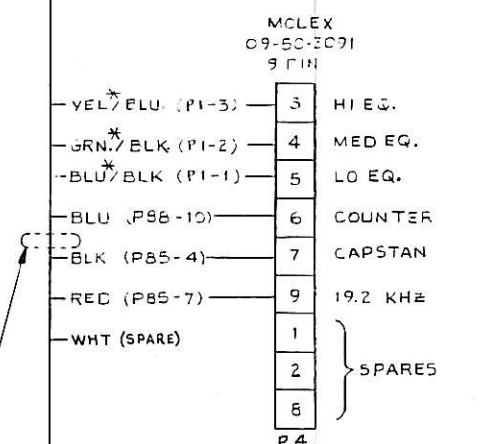

TO J8
A/L-3 PROCESSOR BD
PCA 2500-0611
OR PCA 2500-0639

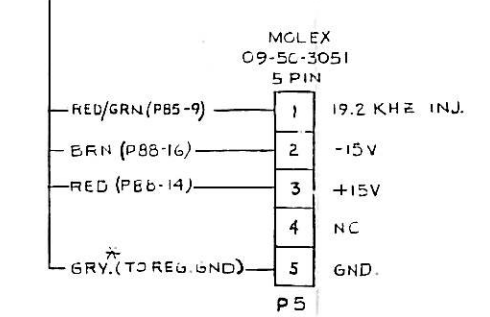

TO J6,
A/L-3 DISPLAY BD.
PCA 2500-0610

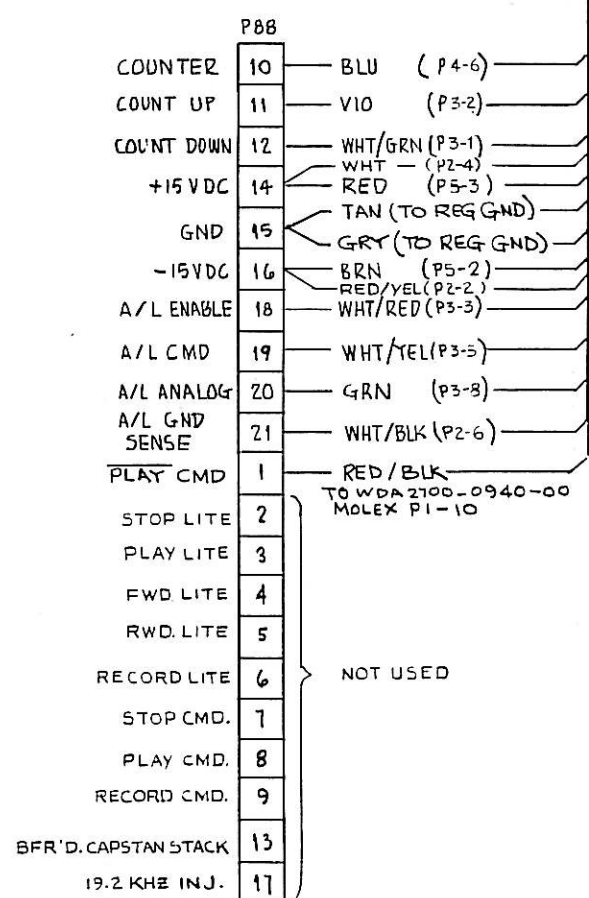

BEAU
P-3321-CCE
SYNC
CONNECTOR

- NOTES:
1. OVERALL CABLE LENGTH IS 40 FEET.
 2. ALL WIRES ARE AWG. #22 STRANDED, EXCEPT CABLE SHIELD WIRE, WHICH IS AWG. #24 STRANDED BARE.
 3. * DENOTES WIRES WHICH ARE NOT PART OF CABLE SF7000-0254-00. (8 WIRES)

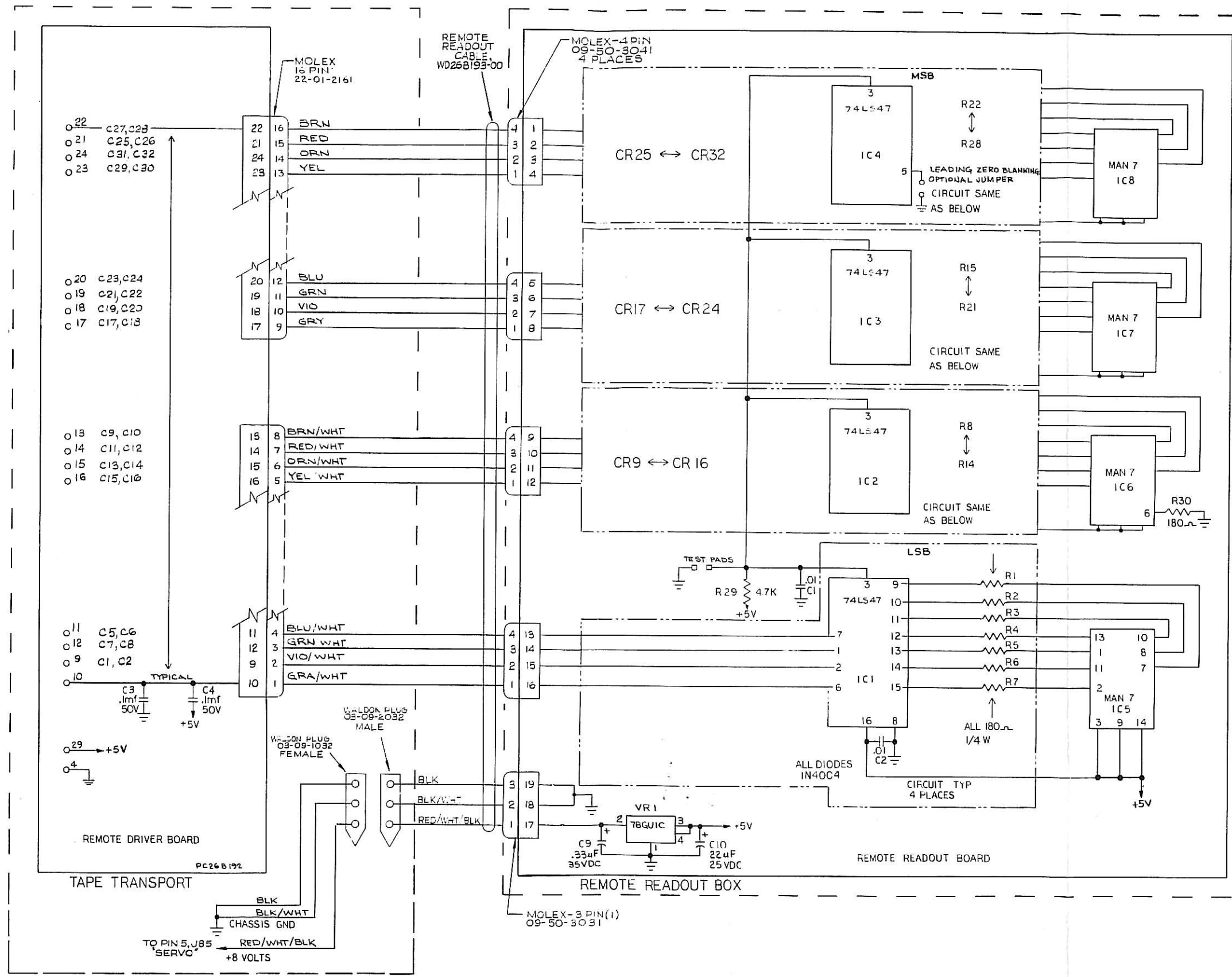

JH-47 Remote Readout
SC26D191
JH-110 SERIES

MOLEX
16-PIN
22-01-2161

REMOTE READOUT
DRIVER NUMBERS

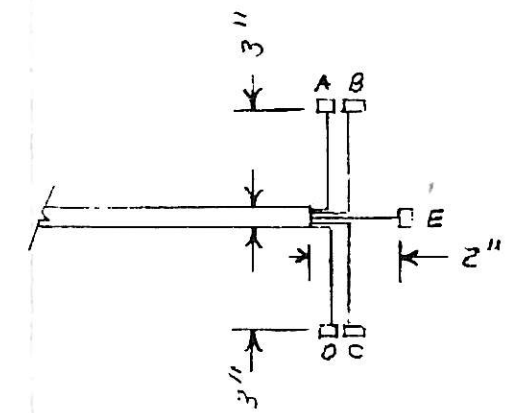
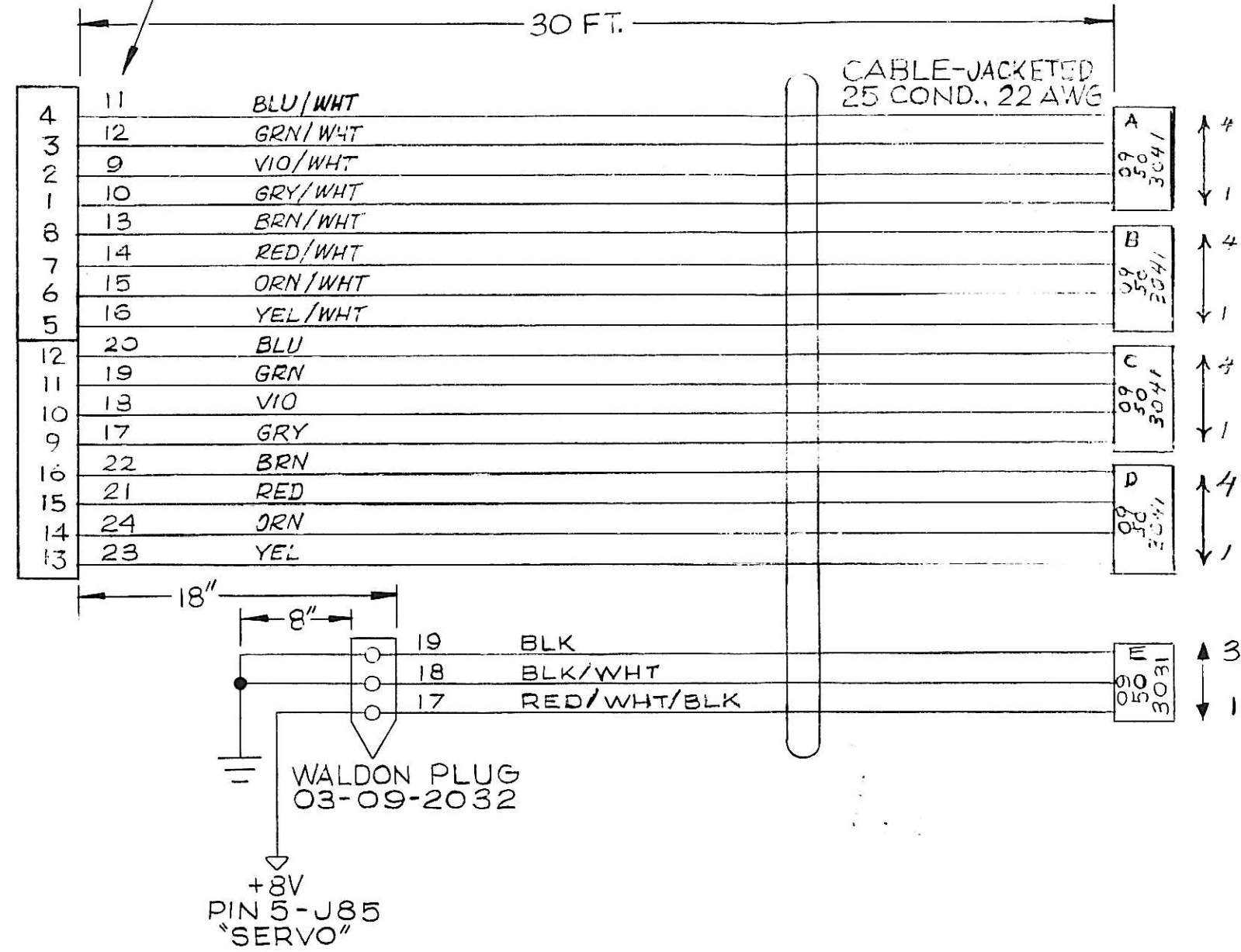

JH-47 Remote Readout Cable
WD26B193
JH-110 SERIES

Section 4

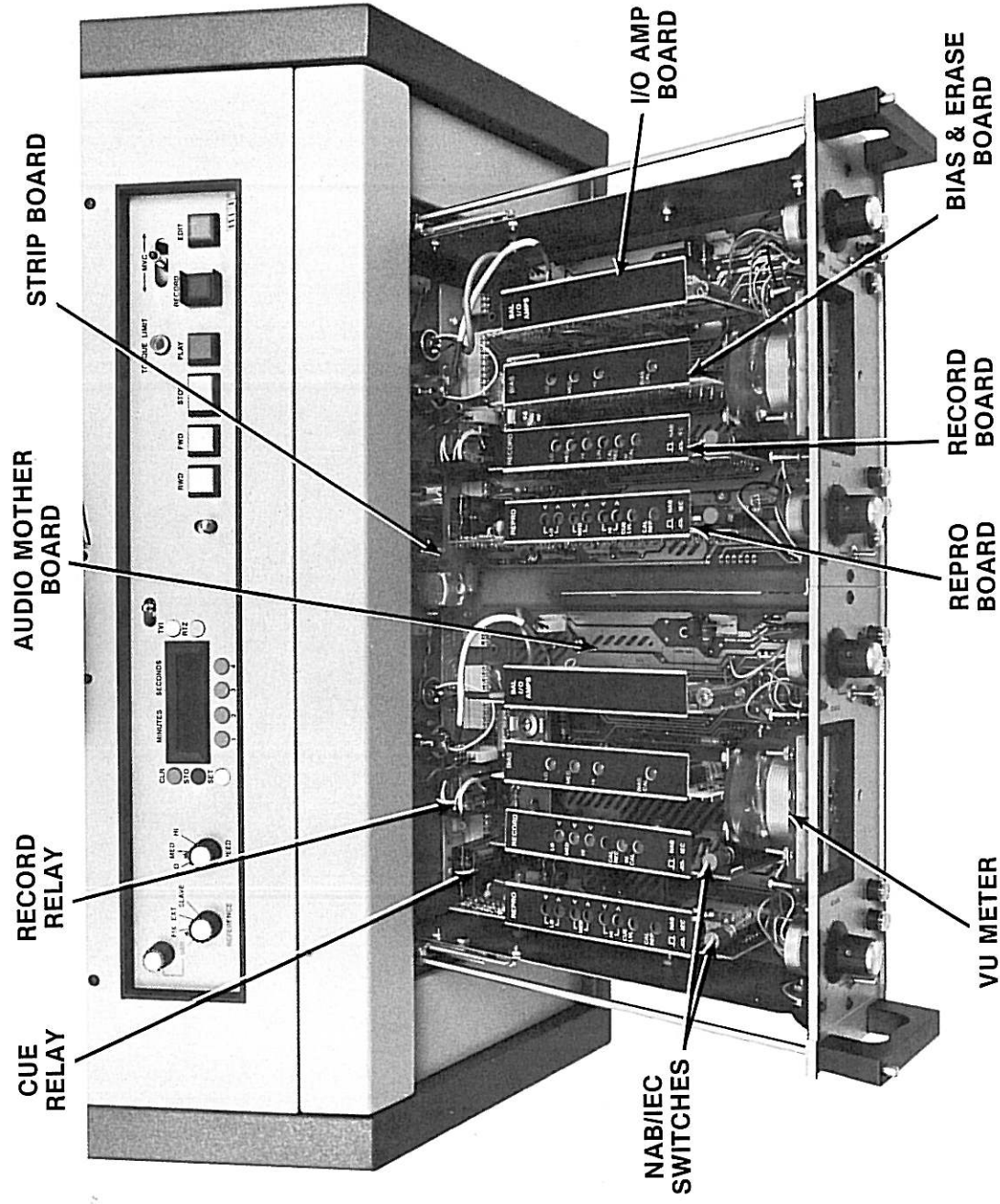

Audio Circuit Board Locations

SECTION 5

AUDIO ELECTRONICS

5.1 General Description

The JH-110B Audio Electronics typically consists of six printed circuit boards: the Strip Board, Mother Board, Repro Board, Record Board, Bias Board, and I/O Board. Variations in the circuitry contained on these boards are indicated on the schematic diagrams and described in Sections 5.4 and 5.5.

The Strip Board mounts at the back of the audio drawer and provides power and control connections to the Mother Boards of both channels. In the top drawer, the Strip Board contains a 120 KHZ master oscillator. Bias and erase signals for all channels are derived from this oscillator.

The Mother Board forms the interconnections between the Repro, Record, Bias, and I/O Boards. These boards, and the record and cue relays, mount directly onto the Mother Board connectors. All the input and output signals are routed through this circuit board.

The Repro Board contains the playback amplifiers and equalization networks. Equalization may be switched to either NAB or IEC standards. Switches on the front panel select the input to the board. The REPRO switch selects the repro head as the

input. In Repro, the output level can be adjusted with the front panel REP level control. The CUE switch selects the record head as the input to the Repro Board. The INPUT switch connects the line input from the Record Board to the Repro Board for monitoring the input to the transport.

The Record Board contains amplifiers and equalization networks for the input signal to the record head. Record level is adjusted with the level control on the front panel. A switch on the circuit board selects either NAB or IEC standard equalization.

The Bias and Erase Board contains amplifiers which supply the bias signal to the record head and the erase signal to the erase head. Bias and erase current are applied to the heads only when the READY switch is pressed in, the SAFE switch is out, and the transport is in record. The BIAS switch on the front panel connects the bias signal to the channel VU meter for an indication of bias current.

The I/O Amplifier Board contains balanced amplifiers for the line input and line output signals. The VU meter indicates the line output level from the I/O board.

This machine conforms to the IEC 268 standard for XLR-3 type connectors.

Contact 1	SHIELD
Contact 2	SIGNAL HIGH
Contact 3	SIGNAL LOW

This machine also conforms to the proposed Stodolsky Magnetic Polarity standard, i.e. tape magnetization in the direction of normal tape motion is defined as positive.

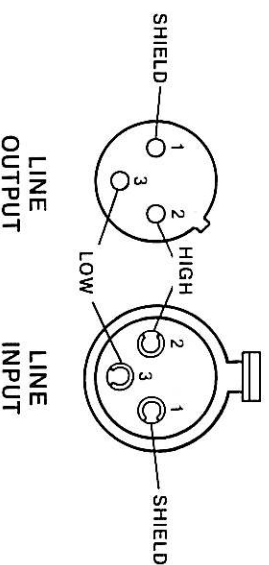

5.2 Record Mode

Figure 5-1, a block diagram, illustrates the circuits involved in the record mode for one channel. Record mode is initiated by pressing the record READY switch button on the front panel and pressing RECORD on the transport. The channels are controlled independently allowing recording and erasing on one, or more, channels while the other channel, or channels, are in the Repro mode.

A shielded cable from the line input audio connector plugs into the I/O Board. Differential input amplifiers amplify the audio input and apply it to the record level potentiometer. If the REC CAL switch is in the CAL position, the calibrated record potentiometer sets the input level to the Record Board.

A parallel signal processing technique is used on both the Record and Repro Boards in the JH-110B audio electronics. This split signal equalization compensates for the amplitude distortion caused by the different gain characteristics at various frequencies. It gives an improved square wave response over previous series processing techniques. The equalization networks can be aligned to either NAB or IEC standards. Once aligned, pressing a button on the circuit board switches the equalization standard.

On the Record Board, the audio signal splits into two paths which are summed together, out of phase, by a summing amp. The lower path in the block diagram, takes the audio signal through a differentiator and the high frequency equalization networks. The differentiator takes the time

derivative of the audio signal, that is, the output amplitude increases with frequency and the phase is shifted by 90° at all frequencies. The equalization networks adjust the high frequency gain characteristics for each of the transport speeds. Signals from the transport speed select switch enable FET switches in the networks to select the corresponding equalization.

The summed signal, Record Out, mixes with the bias signal and is applied to the record head through the record and cue relays. A bias trap prevents the bias signal from feeding back into the Record Board circuitry.

Bias, and the erase signal, come from the master oscillator in the top drawer Strip Board. On the Bias Board FET switches, controlled by the transport speed select switch, select the bias level, ramp time, and the bias and erase timing.

QUIOR circuits (Quiet Initiation Of Record) reduce punch-in and punch-out noise normally associated with switching in and out of record mode. Whenever the bias and erase currents are turned on or off, the amplitude of the current is ramped to minimize transition noise. Also, the erase current is always ramped on and off before the bias current. This is done to compensate for the physical distance between the erase and record heads. The bias current delay is equal to the time it takes the tape to travel the distance between the two heads. Figure 5-2 illustrates how the QUIOR circuits eliminate overlapping and blank spots on the tape during record punch-in and punch-out.

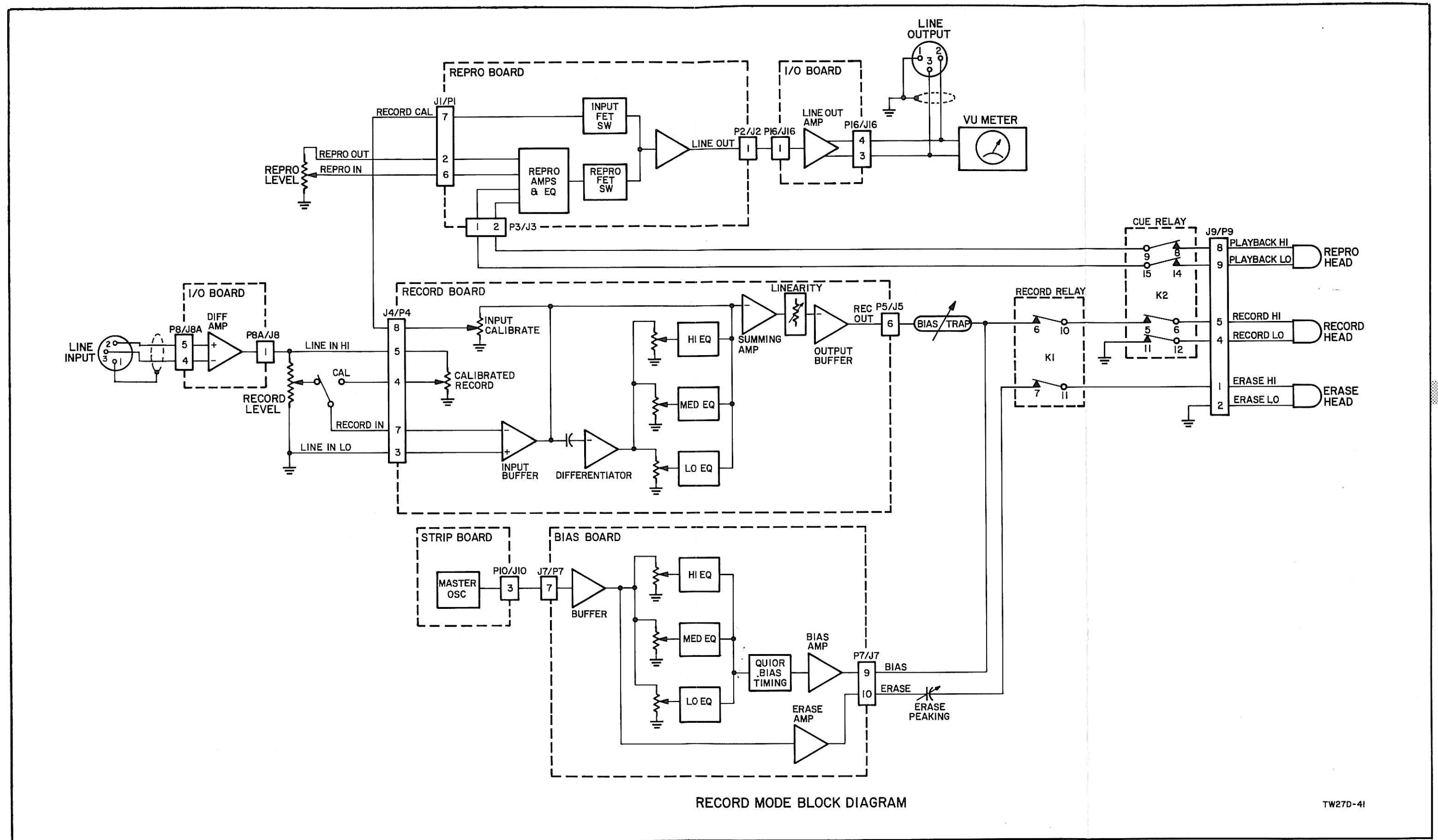

RECORD MODE BLOCK DIAGRAM

TW27D-41

Figure 5-1
Record Mode
Block Diagram

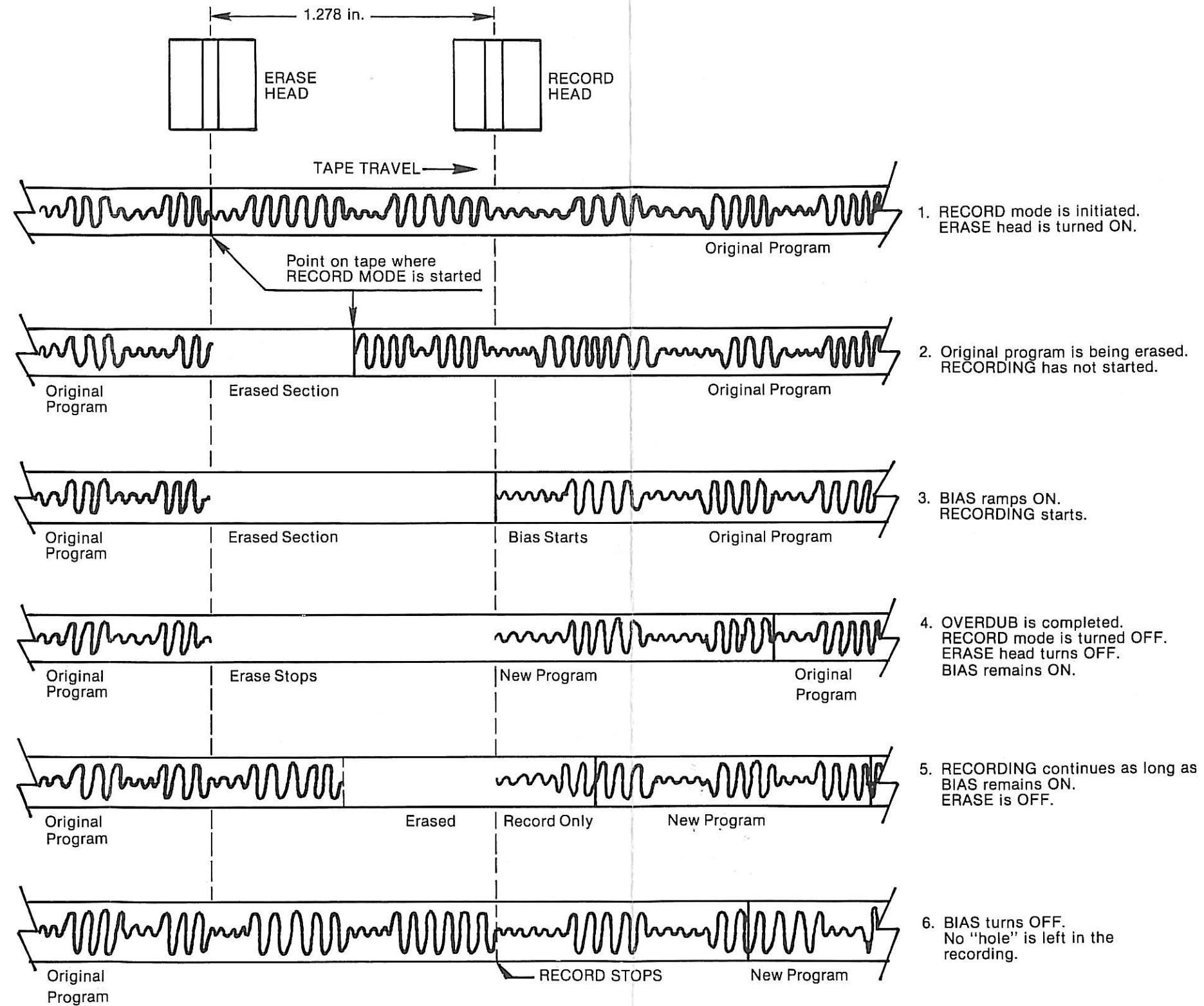

Figure 5-2
Quor Timing
Diagram

The line output and the input to the VU meter in Record mode are selected by the Repro switches: REPRO, INPUT, and CUE. With the REPRO switch pressed, the input to the Repro Board is the audio signal just recorded on the tape and picked up by the repro head. The amplitude of the repro signal can be controlled with the REP level control on the front panel.

With the INPUT or CUE switches pressed in, the input to the Repro Board is the line input from the input calibrate potentiometer on the Record Board. This level is set during alignment; the REP level control has no effect on the line output level when INPUT or CUE are pressed in.

5.3 Reproduce Mode

Refer to Figure 5-3, the Repro mode block diagram. There are three inputs to the Repro Board. The input is selected by the front panel Repro switches which operate FET switches on the Repro Board. With the INPUT switch pressed, the input level is set by the input calibration potentiometer on the Repro Board. The REPRO and CUE switches select the playback signal from the heads; REPRO selects the repro head, CUE selects the record head.

Differential input amplifiers receive the playback signal, amplify it, and split it into two paths for frequency amplitude and phase compensation. The two signals are summed to produce standard response characteristics. The high frequency equalization network selected by the speed select switch determines the gain of the high frequencies at the summing amp.

The low frequency path includes equalization networks and an integrator. The integrated audio signal is shifted in phase at all frequencies by 90°. The amplitude diminishes as the frequency increases.

The REP level control adjusts the line output in REPRO. If the REP CAL switch is in the CAL position, the output level is set by the cal repro potentiometer. In CUE, the output level is set by the cue level potentiometer.

5.4 Broadcast Audio Electronics

The bottom audio drawer contains a Strip Board, Mother Board, I/O Amplifier Board, Record Board, Repro Board, and Bias Board. Signal flow in the Record and Repro modes is similar to that of the standard electronics. Differences in the broadcast electronics are indicated in the schematic diagrams.

Record mode in the broadcast electronics is initiated by pressing the transport PLAY and RECORD buttons at the same time. There are no Record Ready and Safe switches on this audio panel. Both channels enter Record mode simultaneously.

Since this is a two speed machine, there are only high speed and low speed equalization networks on the Record and Repro Boards. The Record and Reproduce levels for each speed are set by the HI LVL and LO LVL potentiometers on these boards. There are no front panel level controls.

The Bias Board used in the broadcast electronics is the same as the one used in the standard electronics. However, the erase signal is sent to a full width mono erase head. Both channels are always erased in either the stereo or mono modes.

The Broadcast I/O Board is the same as the standard I/O Board. In this transport, the line out amplifier does not drive the VU meter directly. Amplifiers on the Monitor Amp Board drive the VU meters.

Refer to the Monitor Amp Board block diagram, Figure 5-4. It represents the circuits and switches mounted in the top drawer.

In stereo mode the Repro output signals from the right and left channels are switched to their respective line output connectors. Buttons on the front panel switch either the right channel, left channel, or a mix of both to the speaker. The VU meters measure either the line input or line output signals of each channel as selected by the meters switches.

In mono mode the Repro output signals from the right and left channels are summed together and sent to the left line output connector. The left line input is applied to both channel inputs. The left channel VU meter can be switched to measure either the left line input or the left line output.

5.5 Mastering Audio Electronics

Each channel in the Mastering deck contains standard reproduce audio electronics. There are no Record or Bias Boards, and the I/O Amplifier Board has no input amplifiers. Differences in the Mother Board and Repr.o-Boards are indicated in the schematic diagrams.

A Front Panel EQ Board, unique to this transport, duplicates the function of the high and low frequency equalization networks on the Repro Board. Potentiometers on the front panel adjust these equalization networks located on the EQ Board. A switch on the front panel can select the standard

equalization aligned on the Repro Board. Or, it can select the equalization adjusted by the front panel controls.

5.6 Eight Track Remote

The JH-110C eight-track recorder can be remotely controlled by the optional remote unit. This remote unit controls both the transport functions and the output mode of the electronics. Control switches on the remote unit override the function of the repro, input, and cue switches on the audio panel. A switch mounted on the audio mother board, inside the audio drawer, selects either local or remote control of the monitoring circuits. The operation of the eight track remote unit is identical to the operation of the remote unit used with the JH-24 Multitrack Recorder. Similar to the Multitrack remote unit, the eight track remote unit provides mounting space and connections for the optional AutoLocator III.

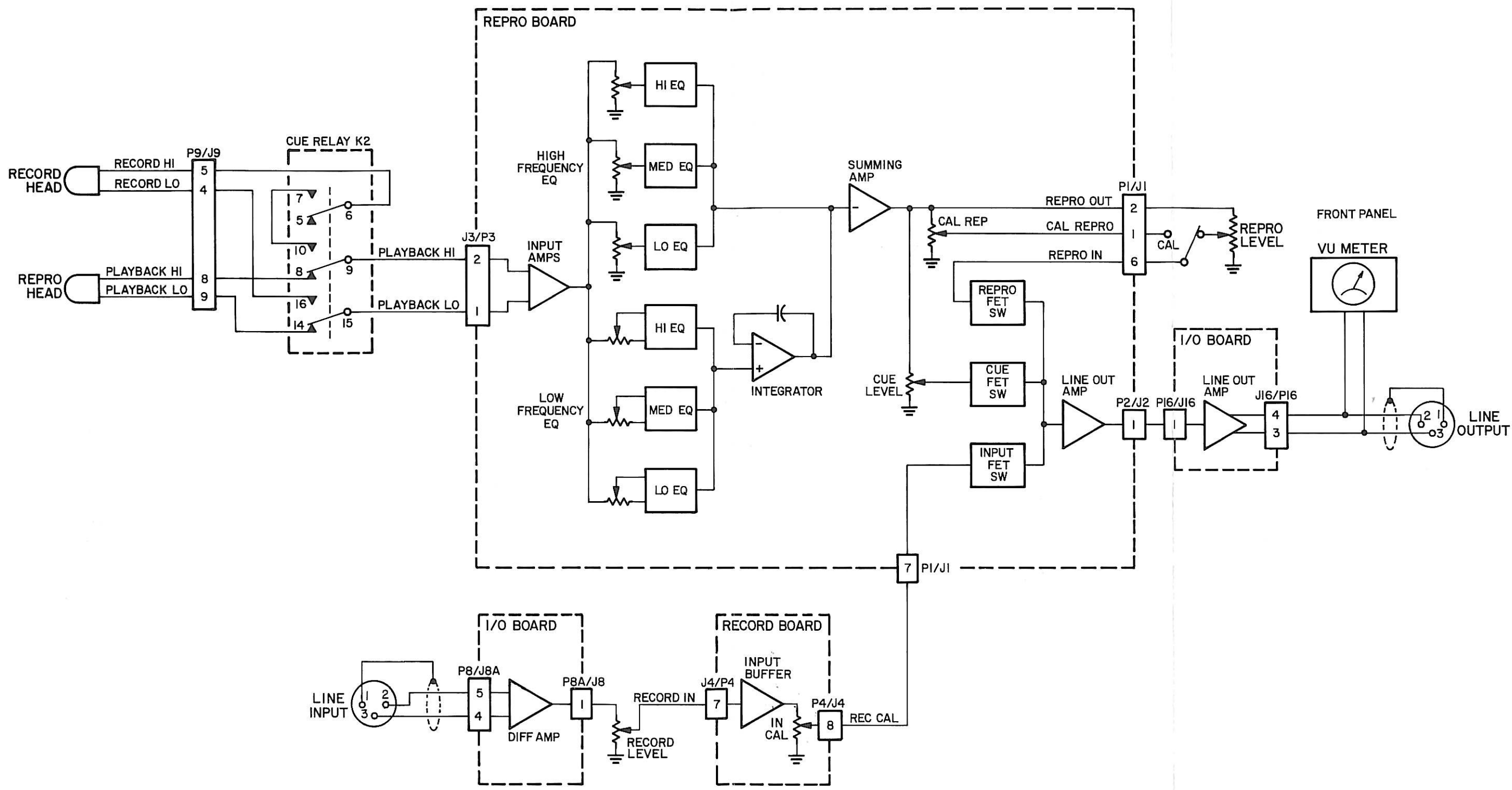

REPRO MODE BLOCK DIAGRAM

TW27D-42

Figure 5-3
Repro Mode Block
Diagram



REDUCE TARGETS A-B TO 6.000 ±.003

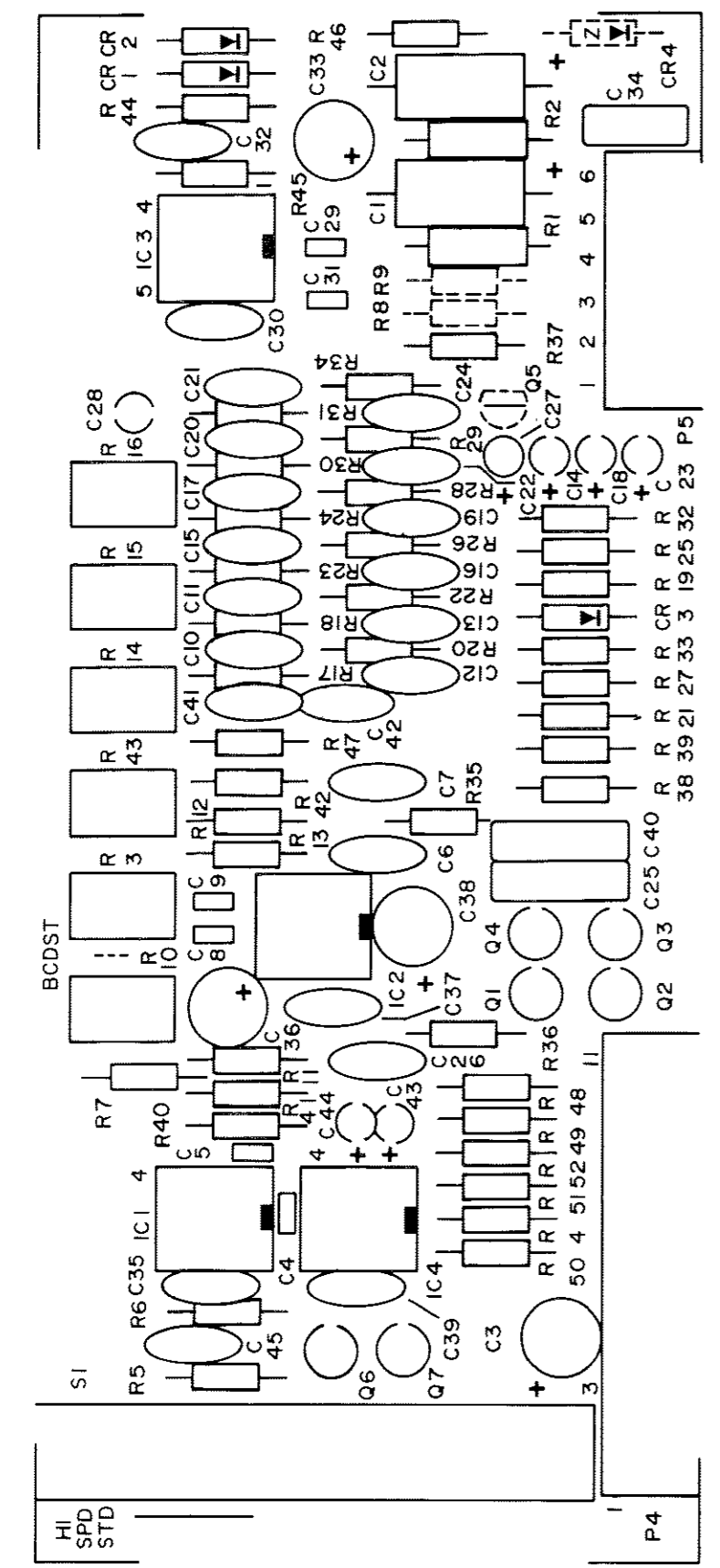
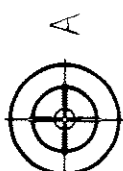

SS2700C0914-00 D
 RECORD BD
 STD & BDCST
 JH-110B

* COMPONENT CHART -1-					* COMPONENT CHART -2-				
BDCST.	COMP. DESIG.	HI SPEED	LO SPEED	EX	BDCST.	COMP. DESIG.	HI SPEED	LO SPEED	EX
---	R10	4.7K	4.7K	---	630PF	C17	630PF	---	---
---	R17	4.7K	4.7K	---	100PF	C19	100PF	330PF	---
---	R20	68K	68K	---	---	C21	---	---	---
---	R22	---	68K	---	230PF	C24	330PF	---	---
---	R24	4.7K	5.6K	---	---	C41	330PF	---	---
---	R28	68K	68K	---	---	C42	OPT.	OPT.	---
---	R31	5.6K	---	---	68uF	C43	---	---	---
---	R34	68K	---	---	68uF	C44	---	---	---
---	R47	3.90K	---	---	---	---	---	---	---
---	R48	---	---	---	---	---	---	---	---
---	R49	---	---	---	---	CR5	IN914	---	---
---	R50	---	---	---	1086	Q6	---	---	---
---	R51	---	---	---	1086	Q7	---	---	---
---	R52	---	---	---	IN	S1	IN	IN	OUT
---	R14	2K POT	2K POT	---	---	---	---	---	---
---	C10	---	120PF	---	---	---	---	---	---
---	C11	---	680PF	---	---	---	---	---	---
---	C12	100PF	270PF	---	---	---	---	---	---
---	C13	---	100PF	---	---	---	---	---	---
---	C15	120PF	---	---	---	---	---	---	---
---	C16	270PF	150PF	---	---	---	---	---	---

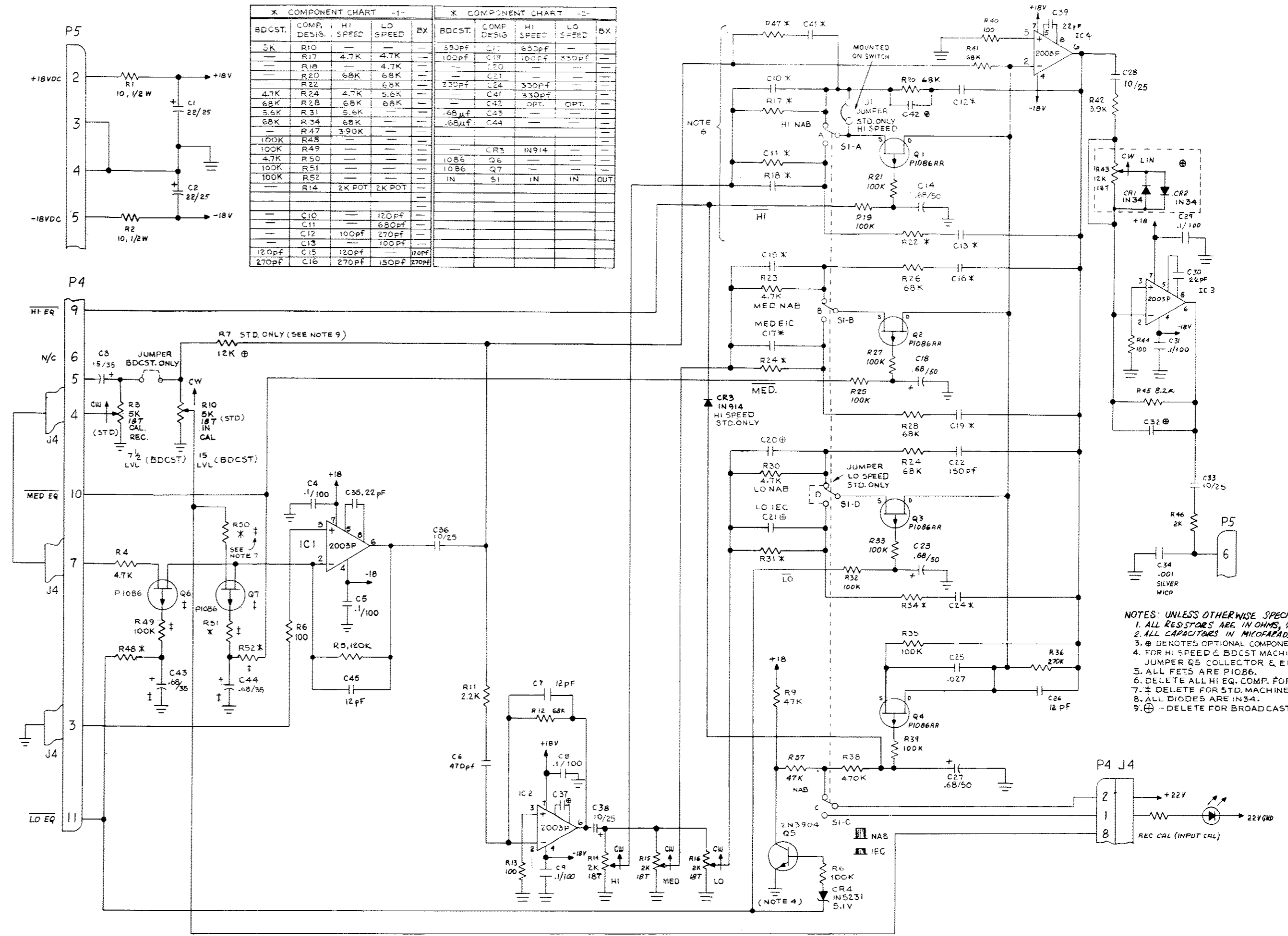

- NOTES: UNLESS OTHERWISE SPECIFIED
1. ALL RESISTORS ARE IN OHMS, UNLESS OTHERWISE SPECIFIED.
 2. ALL CAPACITORS IN MICROFARADS UNLESS OTHERWISE SPECIFIED.
 3. ⊕ DENOTES OPTIONAL COMPONENT NORMALLY NOT REQUIRED.
 4. FOR HI SPEED & BDCST MACHINES DELETE CR4, Q5, RB & R9 JUMPER Q5 COLLECTOR & EMITTER.
 5. ALL FETS ARE P1086.
 6. DELETE ALL HI EQ. COMP. FOR BDCST. MACHINES.
 7. † DELETE FOR STD. MACHINES, JUMPER Q6 SOURCE & DRAIN.
 8. ALL DIODES ARE IN34.
 9. ⊕ - DELETE FOR BROADCAST MACHINES.

**PARTS LIST
RECORD BOARD
PCA2700-0914**

Right Angle Molex Connector 5CIR	09-52-3051
Right Angle Molex Connector 6CIR	09-52-3061
Zener Diode, 5.1V	1N5231B
Diode	1N914
Op-Amp	2003P
Transistor	2N3904
4 Pole Locking Switch	SP-7000-2305-14
Card Pull	MC-2700-0061-01
FET	P1086RR
Potentiometer 2K	SAPCPOT2K-18T
Potentiometer 5K	SAPCPOT5K-18T

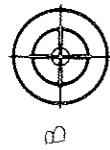

REDUCE TARGETS A-B TO 7.000±0.03

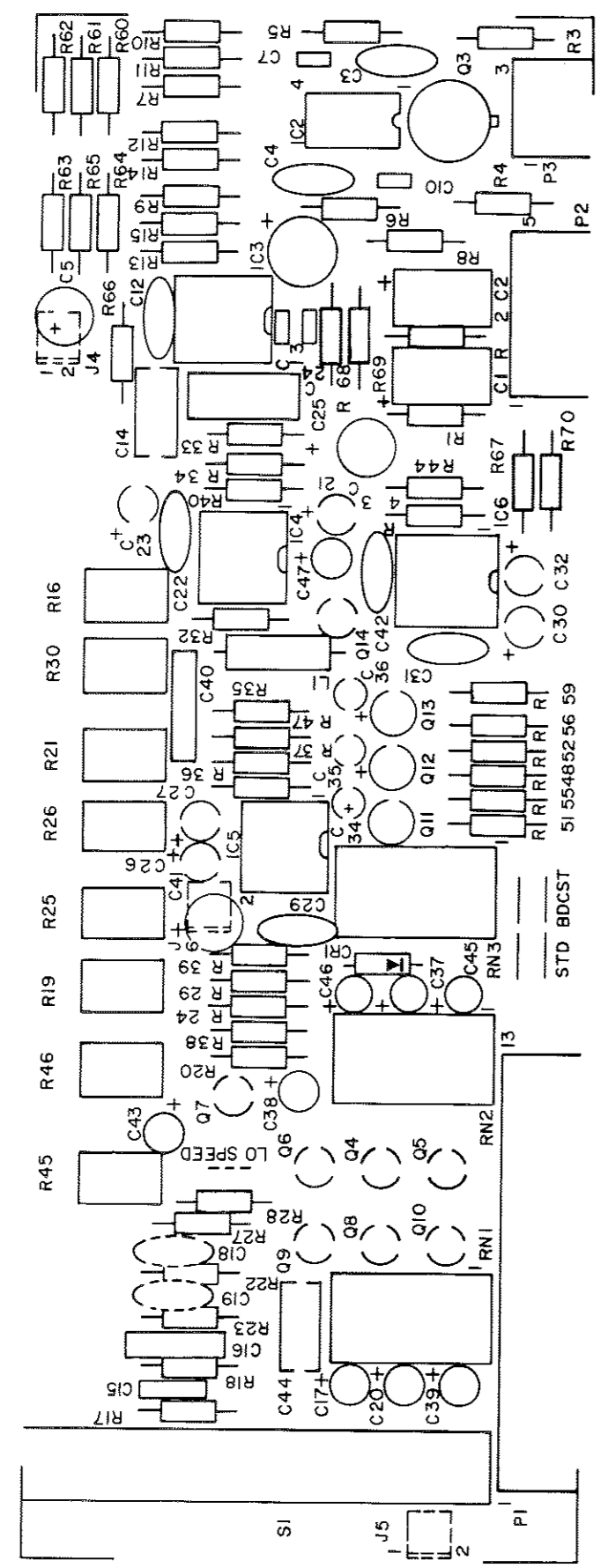

SS2700C0913-00K
SILKSCREEN
REPRO BD, JH-110B
BDCST & STD

5115548525659
STD BDCST

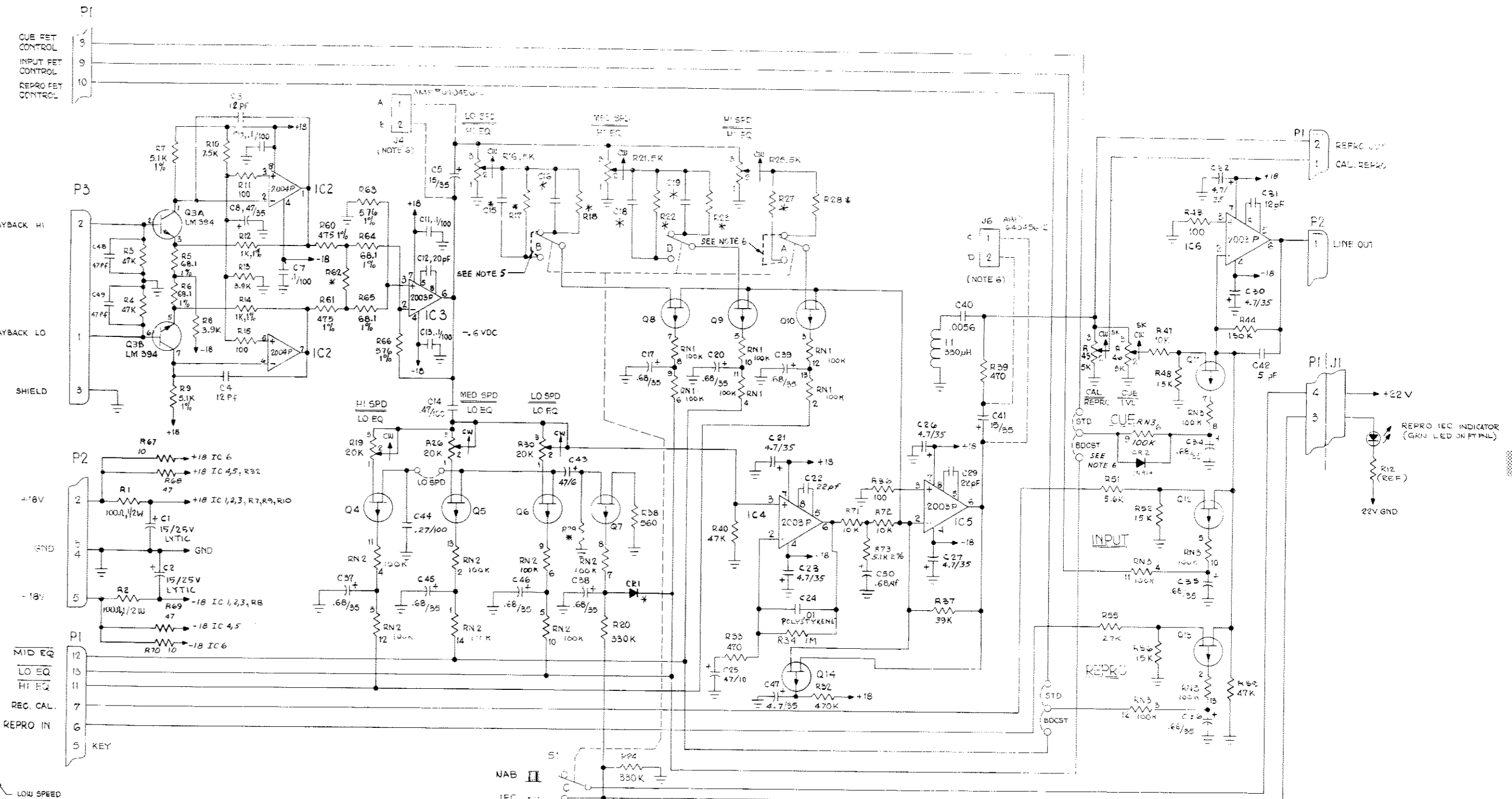
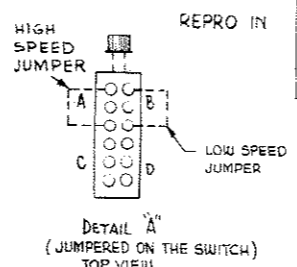

- NOTES: UNLESS OTHERWISE SPECIFIED:
 1. ALL RESISTORS ARE IN OHMS, 1/4 W, 5%
 2. ALL CAPACITORS IN MICROFARADS/VOLTS
 3. * DENOTES OPT. COMPONENT (SEE CHART)
 4. ALL FETS ARE P1086.
 5. FOR LO OR HI SPEED, JUMPER S1 AS SHOWN IN DETAIL "A".
 6. FOR MASTERING MACHINE ONLY:
 R46, R47, R48, R51, R52, C5, C34, C35, C36, C41, Q11, Q12, Q13, RN3 NOT USED.
 JUMPER DRAIN/SOURCE OF Q13.
 7. FOR BDCST C44, C49, C37, C35, Q10, Q4, Q12, R25, R19, R51, R52. NOT USED

COMPONENT	HI SPEED	LO SPEED	BROADCAST	EX
R17	1K	1K	1K	
R18	1.6K	1K	1.8K	1.6K
R25	2.4K	1K	2.4K	
R26	1.2K	1.8K	1.2K	1.6K
R27	6.2K	2.4K		
R28		1.2K		
C15	3300PF		3300PF	
C16	2200PF	3300PF	2200PF	47 PF
C19		2200PF		
C21		100PF		
C22		2200PF		
C23		4.7/35		
C24		4.7/35		
C25		4.7/35		
C26		4.7/35		
C27		4.7/35		
C28		4.7/35		
C29		22PF		
C30		4.7/35		
C31		12PF		
C32		4.7/35		
C33		4.7/35		
C34		4.7/35		
C35		68/35		
C36		68/35		
C37		100K		
C38		100K		
C39		100K		
C40		330UH		
C41		10/35		
C42		5PF		
C43		47/10		
C44		100K		
C45		100K		
C46		100K		
C47		47/10		
C48		47PF		
C49		47PF		
C50		4.7/35		
C51		4.7/35		
C52		4.7/35		
C53		4.7/35		
C54		4.7/35		
C55		4.7/35		
C56		4.7/35		
C57		4.7/35		
C58		4.7/35		
C59		4.7/35		
C60		4.7/35		
C61		4.7/35		
C62		4.7/35		
C63		4.7/35		
C64		4.7/35		
C65		4.7/35		
C66		4.7/35		
C67		4.7/35		
C68		4.7/35		
C69		4.7/35		
C70		4.7/35		
C71		4.7/35		
C72		4.7/35		
C73		4.7/35		
C74		4.7/35		
C75		4.7/35		
C76		4.7/35		
C77		4.7/35		
C78		4.7/35		
C79		4.7/35		
C80		4.7/35		
C81		4.7/35		
C82		4.7/35		
C83		4.7/35		
C84		4.7/35		
C85		4.7/35		
C86		4.7/35		
C87		4.7/35		
C88		4.7/35		
C89		4.7/35		
C90		4.7/35		
C91		4.7/35		
C92		4.7/35		
C93		4.7/35		
C94		4.7/35		
C95		4.7/35		
C96		4.7/35		
C97		4.7/35		
C98		4.7/35		
C99		4.7/35		
C100		4.7/35		

KEY
 1 KEY
 2 E
 AMP #64C456-2

**PARTS LIST
REPRODUCE BOARD
PCA2700-0913-03**

Right Angle Molex Connector 3CIR	09-52-3031
Right Angle Molex Connector 5CIR	09-52-3051
Right Angle Molex Connector 8CIR	09-52-3081
Tantalum Capacitor	100MF20V-CTA10
Op-Amp	2003P
Delevan Choke, 2500-04	330MH
100K Resistor Network	AB-314B104
4 Pole Locking Switch	SP-7000-2305-14
Transistor	LM394H
Card Pull	MC-2700-0060-01
Card Pull Lable	MC-2700-0060-04
P Channel FET	P1086RR
Potentiometer 20K	SAPCPOT20K-18T
Potentiometer 5K	SAPCPTO5K-18T

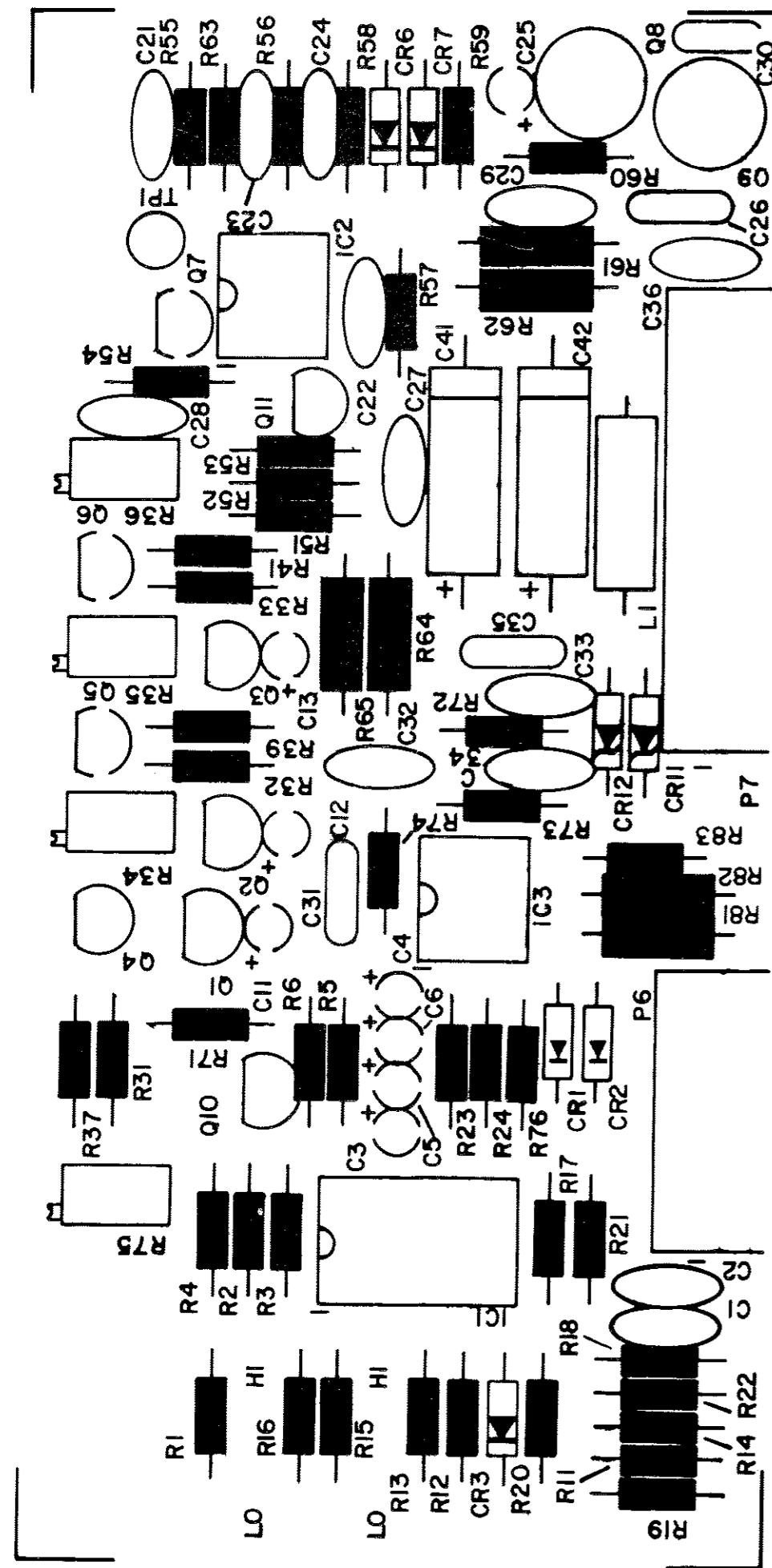

SS2700C0055 B

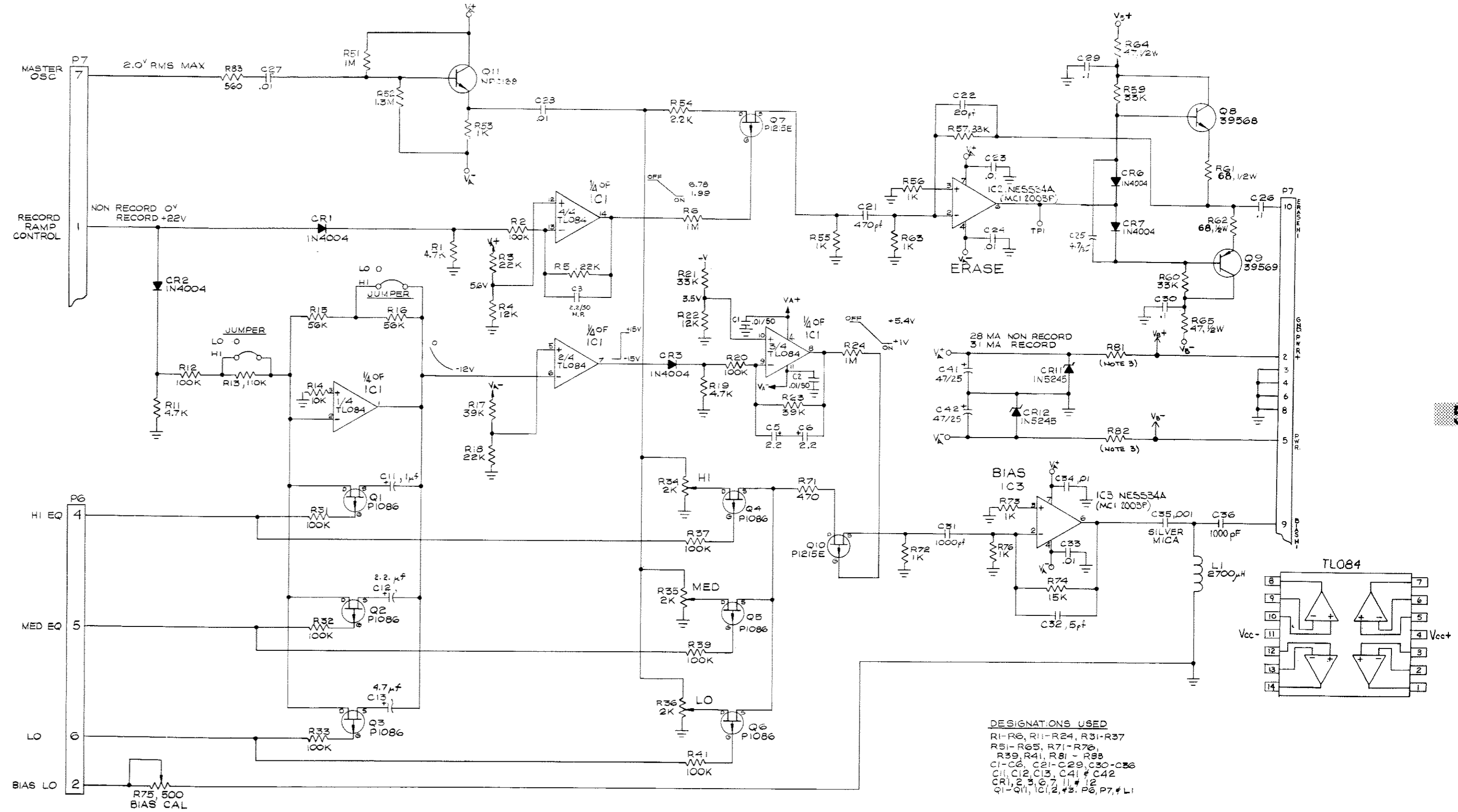

DESIGNATIONS USED
 R1-R6, R11-R24, R31-R37
 R51-R65, R71-R76,
 R59, R41, R81-R83
 C1-C6, C21-C29, C30-C36
 CR1, CR2, CR7, CR11, CR12
 Q1-Q6, IC1, IC2, IC3, P6, P7, L1

NOTES: UNLESS OTHERWISE NOTED
 1—ALL RESISTORS VALUES ARE IN OHMS, 1/4W, 5%
 2— " CAPACITOR " MICROFARADS/VOLTS
 3— PCA 2700-0055-00 (FOR USE ON 24V SYSTEM)
 R81, R82 = 100 Ω, 1/2W V_B = 24V V_A = ±15V
 PCA 2700-0055-01 (FOR USE ON 18V SYSTEM)
 R81, R82 = 68 Ω, 1/2W V_B = ±18V V_A = ±15V

Bias & Erase Board
 SC27D055 rev. M
 JH-110 Series

**PARTS LIST
BIAS/ERASE BOARD
PCA2700-0055-02**

Molex Connector 6CIR	09-52-3061
Molex Connector 10CIR	09-52-3101
Zener Diode	1N5245B-15V
Op Amp	2003P
Delevan Choke	2700MH
PNP Transistor	2N5679-S39569
NPN Transistor	2N5681-S39568
Card Pull	MC-2700-0045-01
Card Pull Lable	MC-2700-0045-02
Transistor, selected	NPC-139
P Channel FET	P1086
P Channel FET, selected	P1215E
Potentiometer	SAPCPOT500-18T
Potentiometer	SAPCPOT2K-18T
Quad OP Amp	TL084CN
Transformer	SP-7000-0111-00
Torroid Transformer	SP-9000-0119-00
Potentiometer	TAPCPOT10K-18T
Potentiometer	TAPCPOT10K-1T
Op Amp	TL081CP

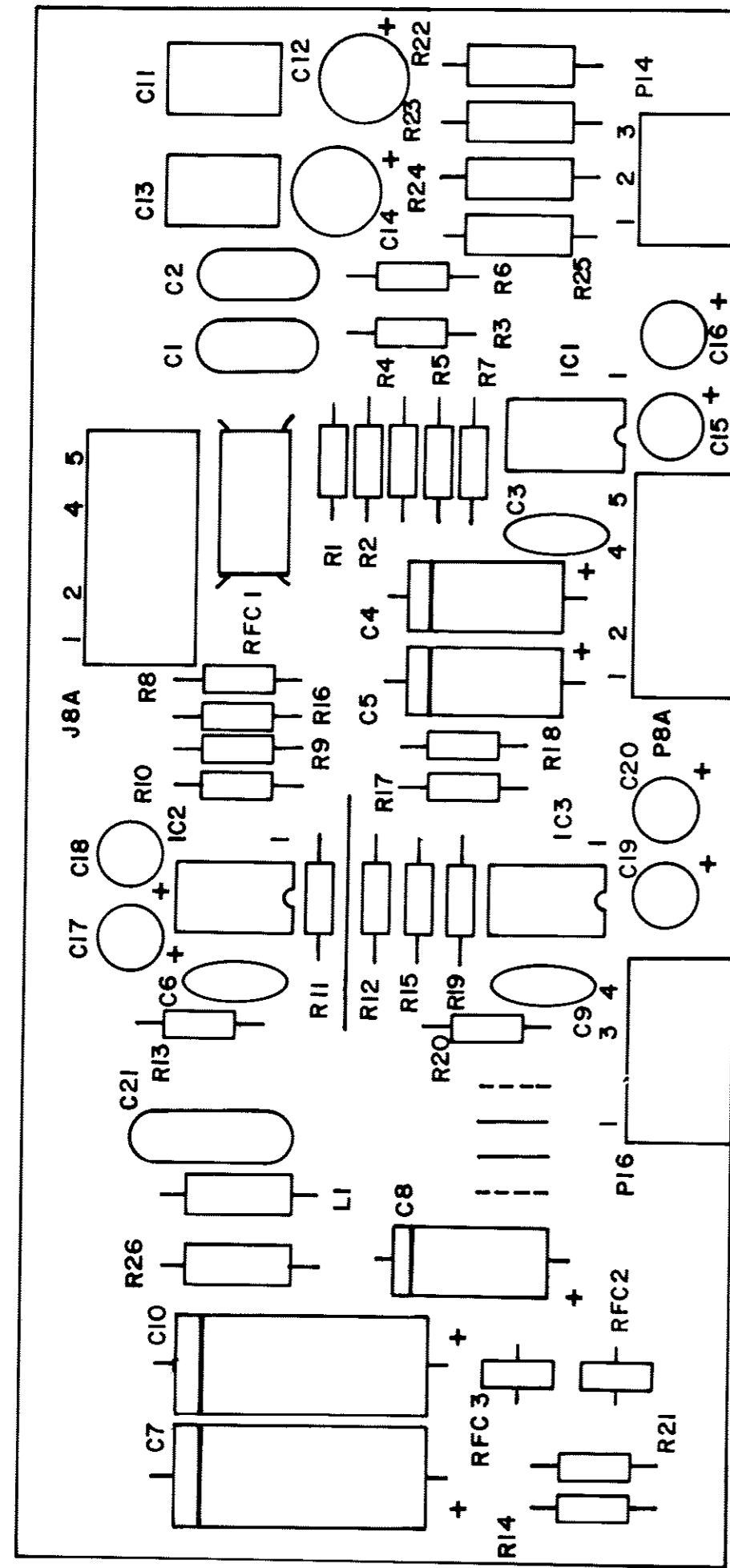

PC2700C0916-00B
SILKSCREEN
I/O CARD, JH10A

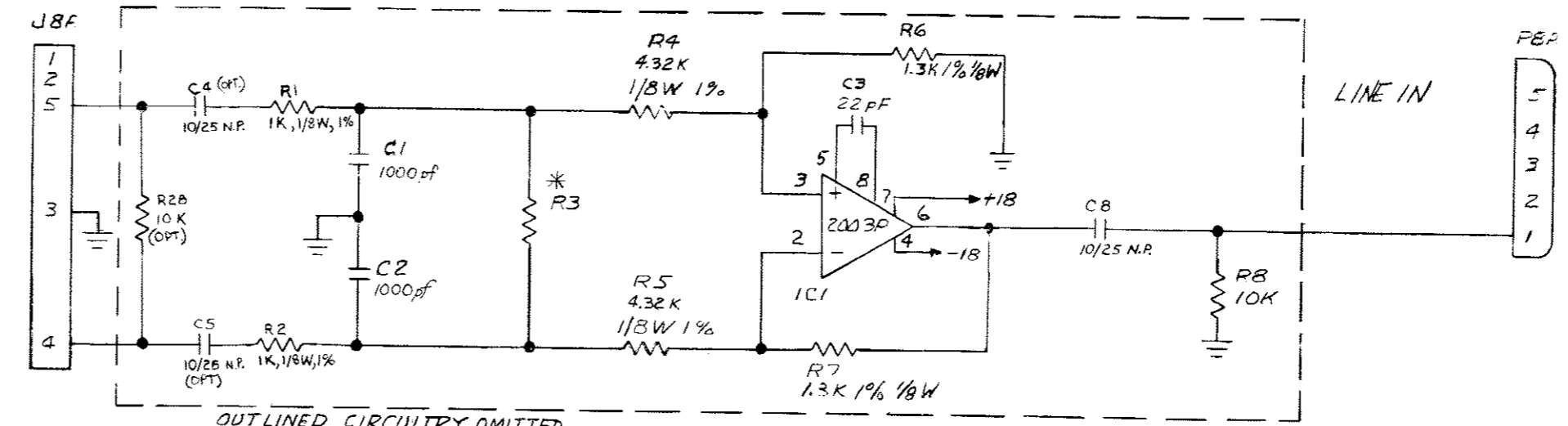

OUTLINED CIRCUITRY OMITTED FROM -02 REPRO ONLY CARD

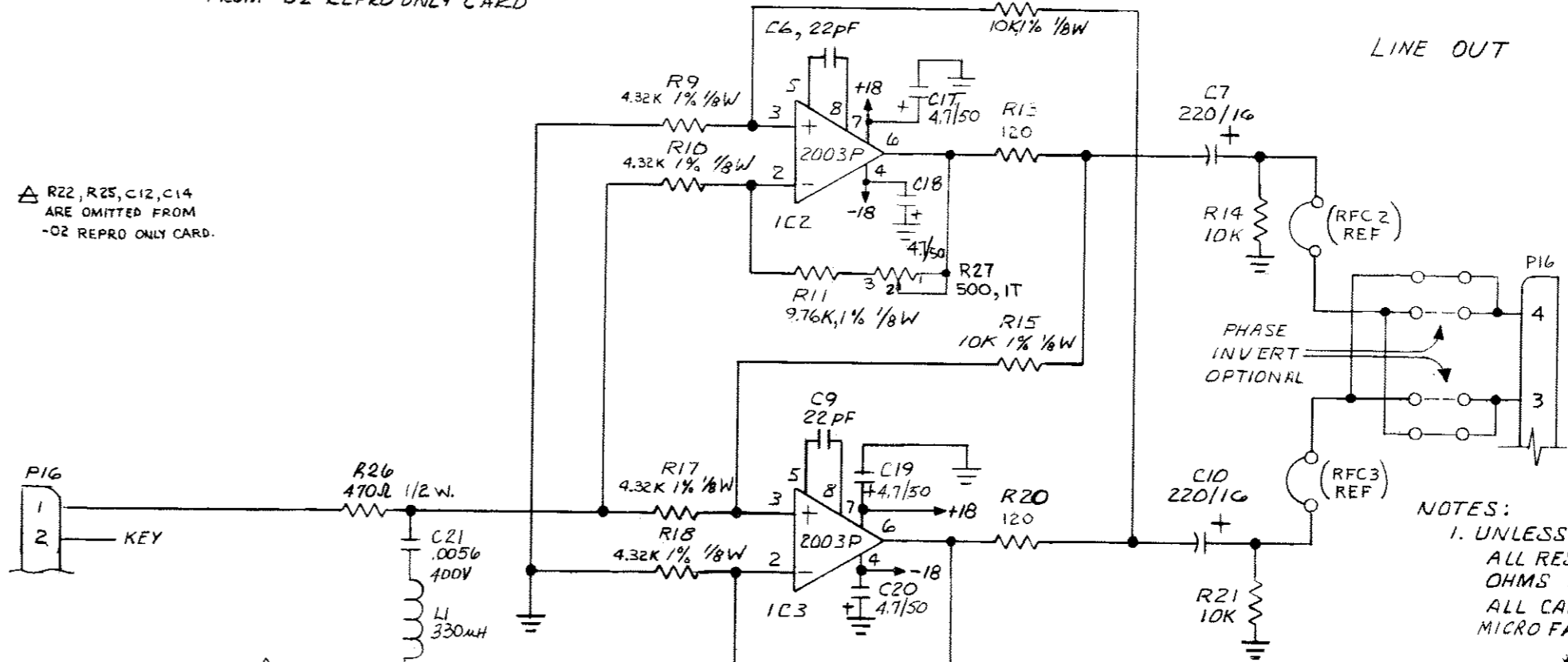

△ R22, R25, C12, C14 ARE OMITTED FROM -02 REPRO ONLY CARD.

NOTES:
1. UNLESS OTHERWISE SPECIFIED, ALL RESISTOR VALUES ARE IN OHMS 1/4W 5%. ALL CAPACITOR VALUES ARE IN MICRO FARADS.

*-00 FULL FUNCTION I/O CARD
*-02 REPRO ONLY, LINE INPUT CIRCUITRY OMITTED.

LAST REF DESIG USED	REF. DESIG NOT USED
C21	
IC3	
R26	

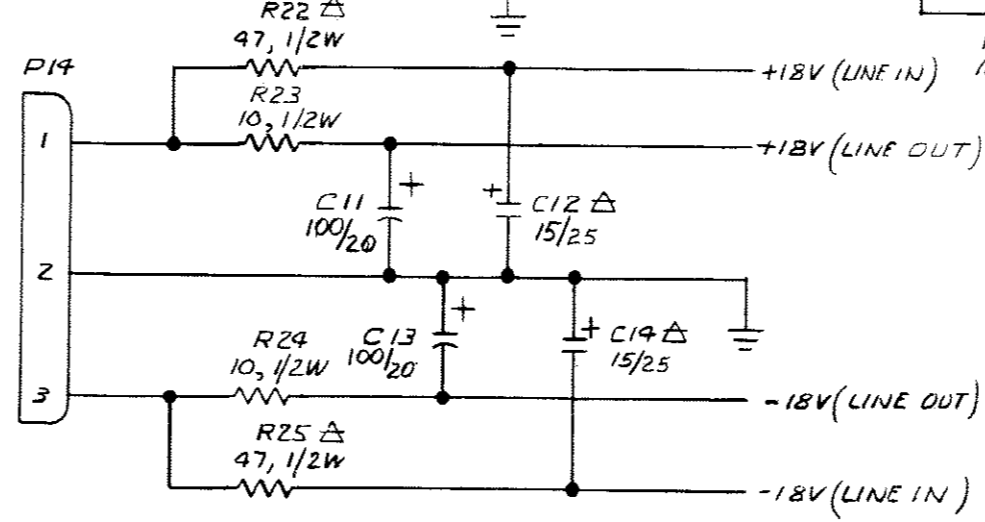

**PARTS LIST
I/O BOARD
PCA2700-0619-00**

Right Angle Molex Connector 3CIR	09-52-3031
Right Angle Molex Connector 4CIR	09-52-3041
Right Angle Molex Connector 5CIR	09-52-3051
5 Pin Molex Connector, Locking	09-65-1051
Op-Amp	2003P
Delevan Choke, 2500-04	330MH
Card Pull	MC-2700-0045-01
Card Pull Lable	MC-2700-0082-07

Differential Output Symmetry Adjustment

NOTE: Perform this adjustment ONLY if components in the line output circuitry have been changed.

1. Connect a signal generator to the line input. Set the controls for a 1kHz signal at +4dBv.
2. Press INPUT. Monitor the line output with a dual trace oscilloscope. Connect the oscilloscope channel A input between the line output high and ground. Connect the oscilloscope channel B input between the line output low and ground. The vertical sensitivity of each channel must be the same.
3. Adjust potentiometer R27 so that both signals have equal amplitude.

If you do not have access to a dual trace oscilloscope, an ac voltmeter may be used. Alternately measure each output, referenced to ground, and adjust for equal meter readings.

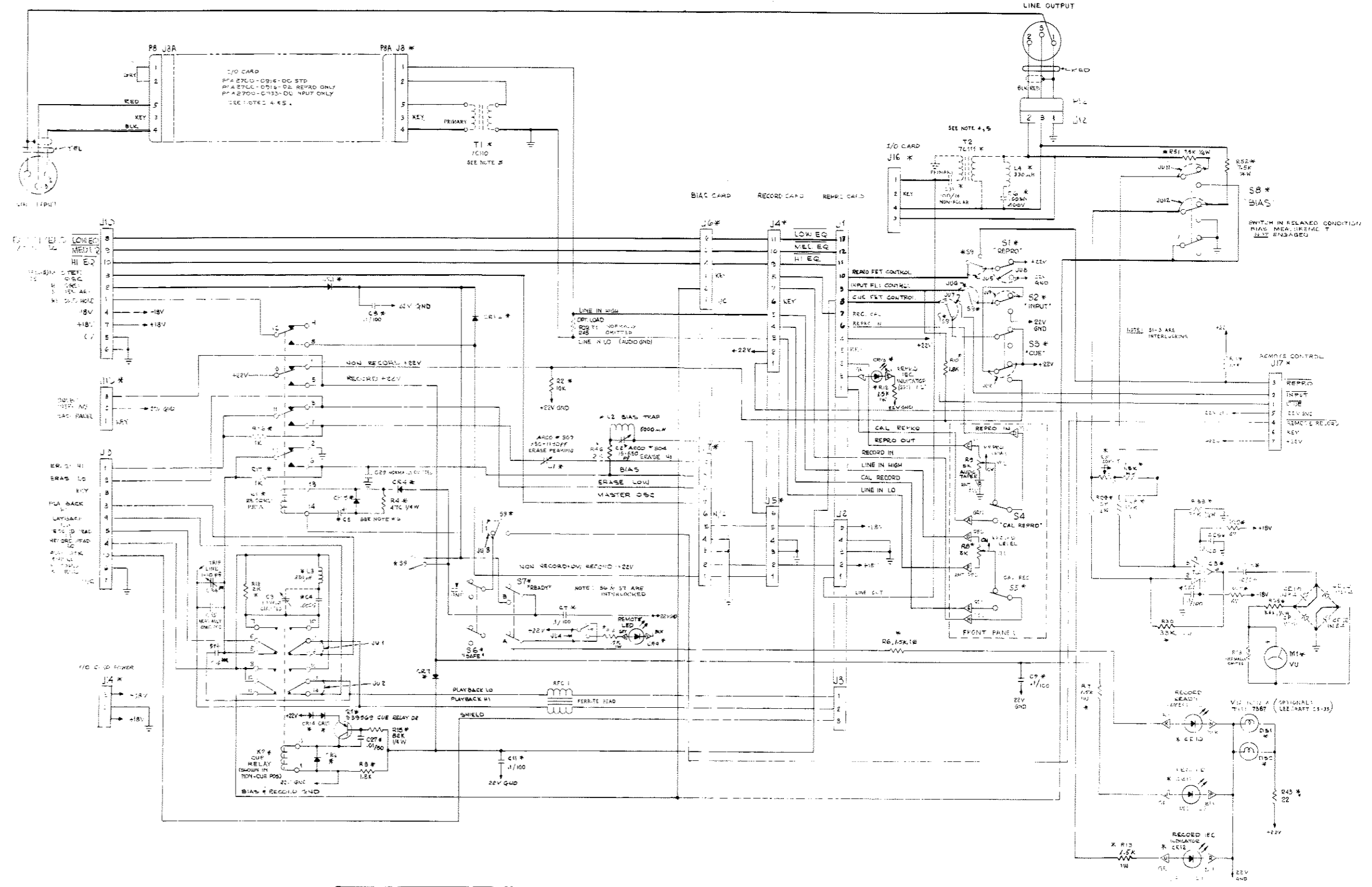
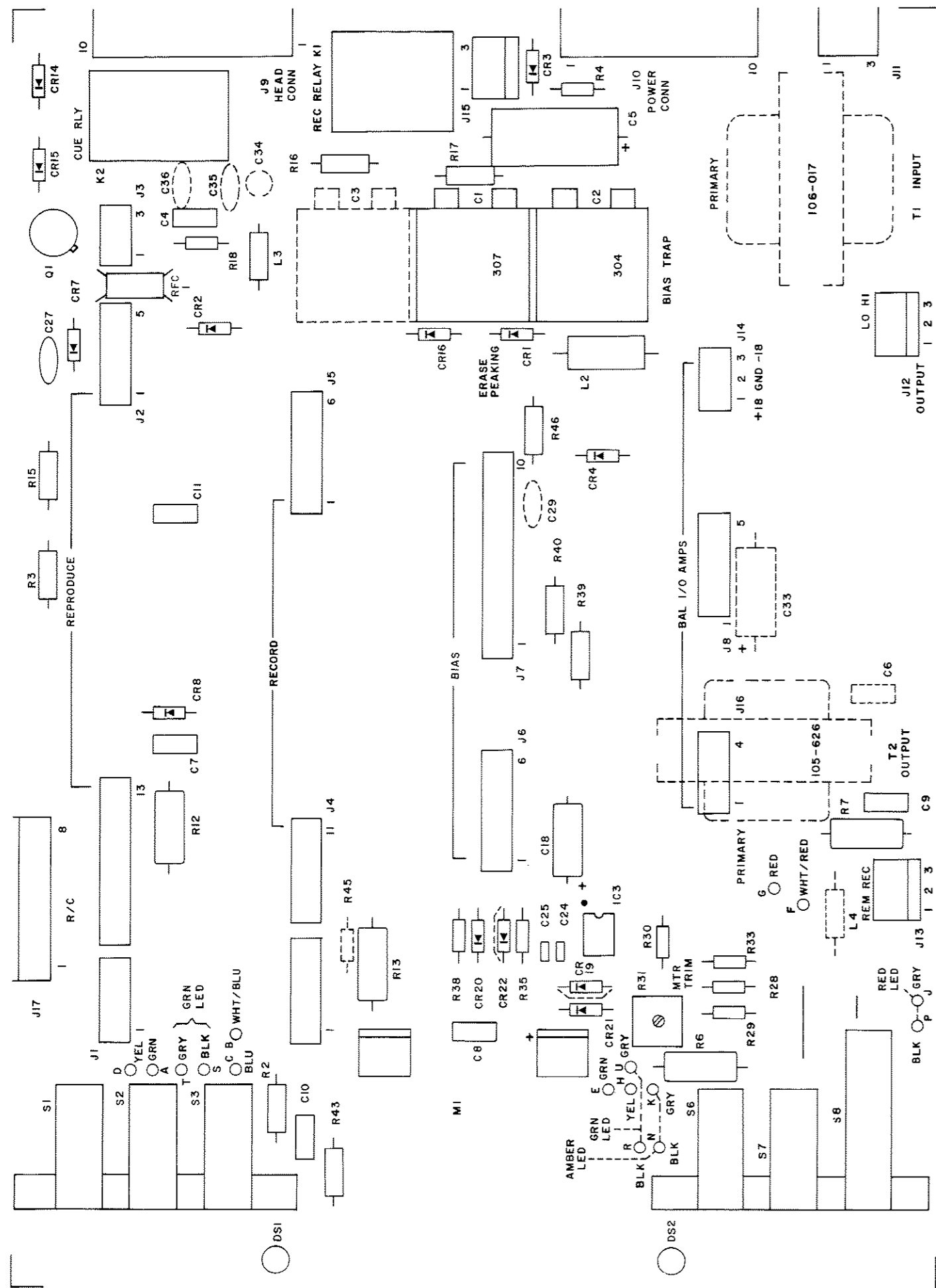

NOTE: 1. ALL COMPONENTS SPECIFIED IN THIS SCHEMATIC ARE IN STOCK AND AVAILABLE IN QUANTITIES OF 1000 UNLESS OTHERWISE SPECIFIED.

2. ALL DIMENSIONS ARE IN INCHES (FRONT VIEW) UNLESS OTHERWISE SPECIFIED.

3. ALL DIMENSIONS ARE IN MILLIMETERS (FRONT VIEW) UNLESS OTHERWISE SPECIFIED.

4. T1, T2, C1, C2, C3, AND C4 ARE 200-0916-00 FOR TRANSFORMER COUPLED OUTPUT (C.O.).

5. T1, T2, C1, C2, AND C3 REPLACE PCA2700-0916-00 FOR TRANSFORMER COUPLED OUTPUT (C.O.).

6. C2 IS 200-0916-00 FOR TRANSFORMER COUPLED OUTPUT (C.O.).

7. S1 REMOTE CONTROL SWITCH IS SHOWN IN NORMAL CLOSED POSITION, LOCAL MODE.

LAST REV. DESIGNED	REV. RESIGNED/REV. USED	OPTIONAL FUNCTIONS	COMPONENTS INVOLVED	-00	-01	-02	-03	-04	-05	-06	-07	-08	-09	-10	ADDITIONAL NOTES
C1A	C1B	RECORD	RECORD	YES	NO	NO	NO	NO	NO	NO	NO	NO	NO	NO	
C2A	C2B	REPRO	REPRO	YES	NO	NO	NO	NO	NO	NO	NO	NO	NO	NO	
C3A	C3B	BIAS	BIAS	YES	NO	NO	NO	NO	NO	NO	NO	NO	NO	NO	
C4A	C4B	REPRO	REPRO	YES	NO	NO	NO	NO	NO	NO	NO	NO	NO	NO	
C5A	C5B	REPRO	REPRO	YES	NO	NO	NO	NO	NO	NO	NO	NO	NO	NO	
C6A	C6B	REPRO	REPRO	YES	NO	NO	NO	NO	NO	NO	NO	NO	NO	NO	
C7A	C7B	REPRO	REPRO	YES	NO	NO	NO	NO	NO	NO	NO	NO	NO	NO	
C8A	C8B	REPRO	REPRO	YES	NO	NO	NO	NO	NO	NO	NO	NO	NO	NO	
C9A	C9B	REPRO	REPRO	YES	NO	NO	NO	NO	NO	NO	NO	NO	NO	NO	
C10A	C10B	REPRO	REPRO	YES	NO	NO	NO	NO	NO	NO	NO	NO	NO	NO	
C11A	C11B	REPRO	REPRO	YES	NO	NO	NO	NO	NO	NO	NO	NO	NO	NO	
C12A	C12B	REPRO	REPRO	YES	NO	NO	NO	NO	NO	NO	NO	NO	NO	NO	
C13A	C13B	REPRO	REPRO	YES	NO	NO	NO	NO	NO	NO	NO	NO	NO	NO	
C14A	C14B	REPRO	REPRO	YES	NO	NO	NO	NO	NO	NO	NO	NO	NO	NO	
C15A	C15B	REPRO	REPRO	YES	NO	NO	NO	NO	NO	NO	NO	NO	NO	NO	
C16A	C16B	REPRO	REPRO	YES	NO	NO	NO	NO	NO	NO	NO	NO	NO	NO	
C17A	C17B	REPRO	REPRO	YES	NO	NO	NO	NO	NO	NO	NO	NO	NO	NO	
C18A	C18B	REPRO	REPRO	YES	NO	NO	NO	NO	NO	NO	NO	NO	NO	NO	
C19A	C19B	REPRO	REPRO	YES	NO	NO	NO	NO	NO	NO	NO	NO	NO	NO	
C20A	C20B	REPRO	REPRO	YES	NO	NO	NO	NO	NO	NO	NO	NO	NO	NO	
C21A	C21B	REPRO	REPRO	YES	NO	NO	NO	NO	NO	NO	NO	NO	NO	NO	
C22A	C22B	REPRO	REPRO	YES	NO	NO	NO	NO	NO	NO	NO	NO	NO	NO	
C23A	C23B	REPRO	REPRO	YES	NO	NO	NO	NO	NO	NO	NO	NO	NO	NO	
C24A	C24B	REPRO	REPRO	YES	NO	NO	NO	NO	NO	NO	NO	NO	NO	NO	
C25A	C25B	REPRO	REPRO	YES	NO	NO	NO	NO	NO	NO	NO	NO	NO	NO	
C26A	C26B	REPRO	REPRO	YES	NO	NO	NO	NO	NO	NO	NO	NO	NO	NO	
C27A	C27B	REPRO	REPRO	YES	NO	NO	NO	NO	NO	NO	NO	NO	NO	NO	
C28A	C28B	REPRO	REPRO	YES	NO	NO	NO	NO	NO	NO	NO	NO	NO	NO	
C29A	C29B	REPRO	REPRO	YES	NO	NO	NO	NO	NO	NO	NO	NO	NO	NO	
C30A	C30B	REPRO	REPRO	YES	NO	NO	NO	NO	NO	NO	NO	NO	NO	NO	
C31A	C31B	REPRO	REPRO	YES	NO	NO	NO	NO	NO	NO	NO	NO	NO	NO	
C32A	C32B	REPRO	REPRO	YES	NO	NO	NO	NO	NO	NO	NO	NO	NO	NO	
C33A	C33B	REPRO	REPRO	YES	NO	NO	NO	NO	NO	NO	NO	NO	NO	NO	
C34A	C34B	REPRO	REPRO	YES	NO	NO	NO	NO	NO	NO	NO	NO	NO	NO	
C35A	C35B	REPRO	REPRO	YES	NO	NO	NO	NO	NO	NO	NO	NO	NO	NO	
C36A	C36B	REPRO	REPRO	YES	NO	NO	NO	NO	NO	NO	NO	NO	NO	NO	

**PARTS LIST
AUDIO MOTHER BOARD
PCA2700-0917-00**

Right Angle Molex Connector 3CIR	09-52-3031	Trim Capacitor	304-CT
Right Angle Molex Connector 10CIR	09-5203101	Trim Capacitor	307-CT
3 Pin Molex Connector	09-64-1031	Delevan Choke, 2500-04	5000MH
4 Pin Molex Connector	09-64-1041	Lamp, 28 volt	SP-7000-0550-00
5 Pin Molex Connector	09-64-1051	Relay	HC4E-24VDC
6 Pin Molex Connector	09-64-1061	Relay	K4E24V-9
8 Pin Molex Connector	09-64-1081	Switch Assembly	SP-7100-2307-06
10 Pin Molex Connector	09-64-1101	Switch Assembly	SP-7100-2307-07
3 Pin Molex Connector, Locking	09-65-1031	Potentiometer, 10K	TAPCPOT10K-1T
5 Pin Molex Connector, Locking	09-65-1051	Op-Amp	TL081CP
Rectifier Diode	1N4004	VU Meter	52-5488
Relay Socket	27E007	Knob, black	7FB2B2
Relay Socket	27E129	5K Audio Potentiometer	CM39704
Bi-Pin Socket	22-5	2K Audio Potentiometer	CM40846
Transistor	2N5679-S39569	LED, Amber	L41-1-0-000A
		LED, Red	L41-2-0-000A
		LED, Green	L41-4-0-000A
		Toggle Switch	MST-105D
		Shadow Switch	SP-7100-2305-06 SP-7100-2305-07
		RF Choke	F2365-1-Q1

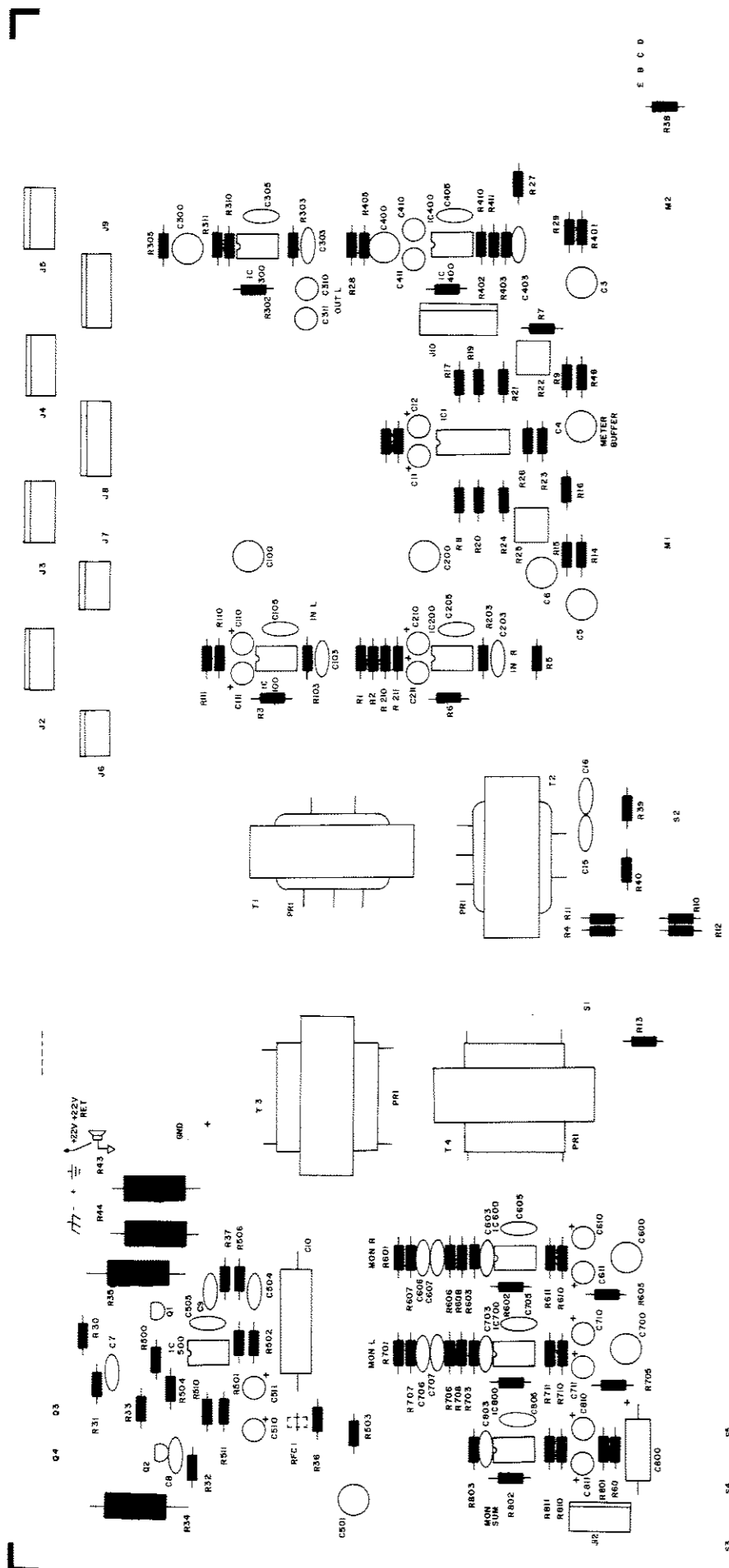

BROADCAST AMP
SS2700080-00-A

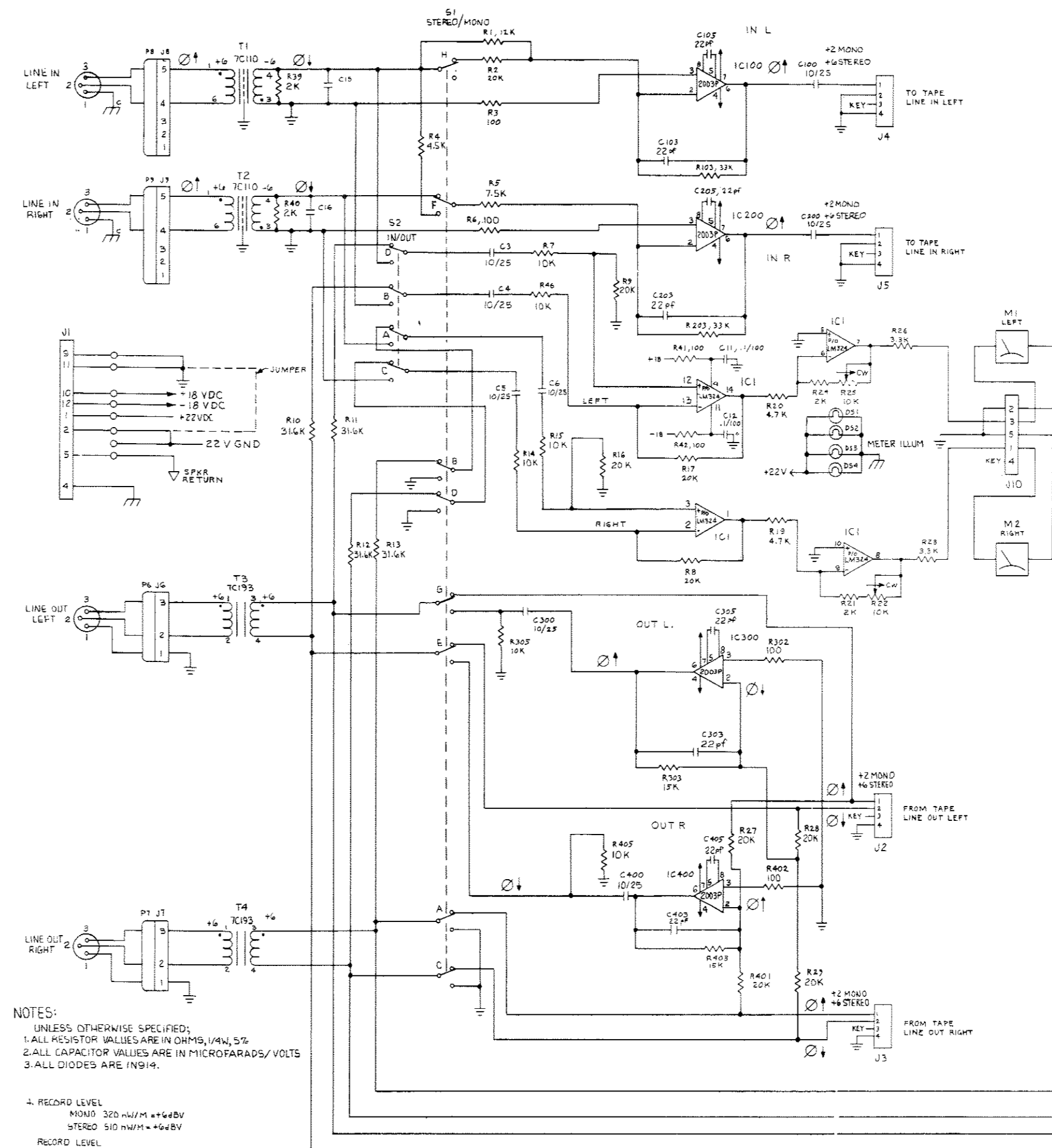

NOTES:
UNLESS OTHERWISE SPECIFIED:
1. ALL RESISTOR VALUES ARE IN OHMS, 1/4W, 5%
2. ALL CAPACITOR VALUES ARE IN MICROFARADS/VOLTS
3. ALL DIODES ARE 1N914.

RECORD LEVEL
MONO 320 nW/M +6dBV
STEREO 510 nW/M +6dBV

RECORD LEVEL
MONO 320 nW/M
STEREO 510 nW/M

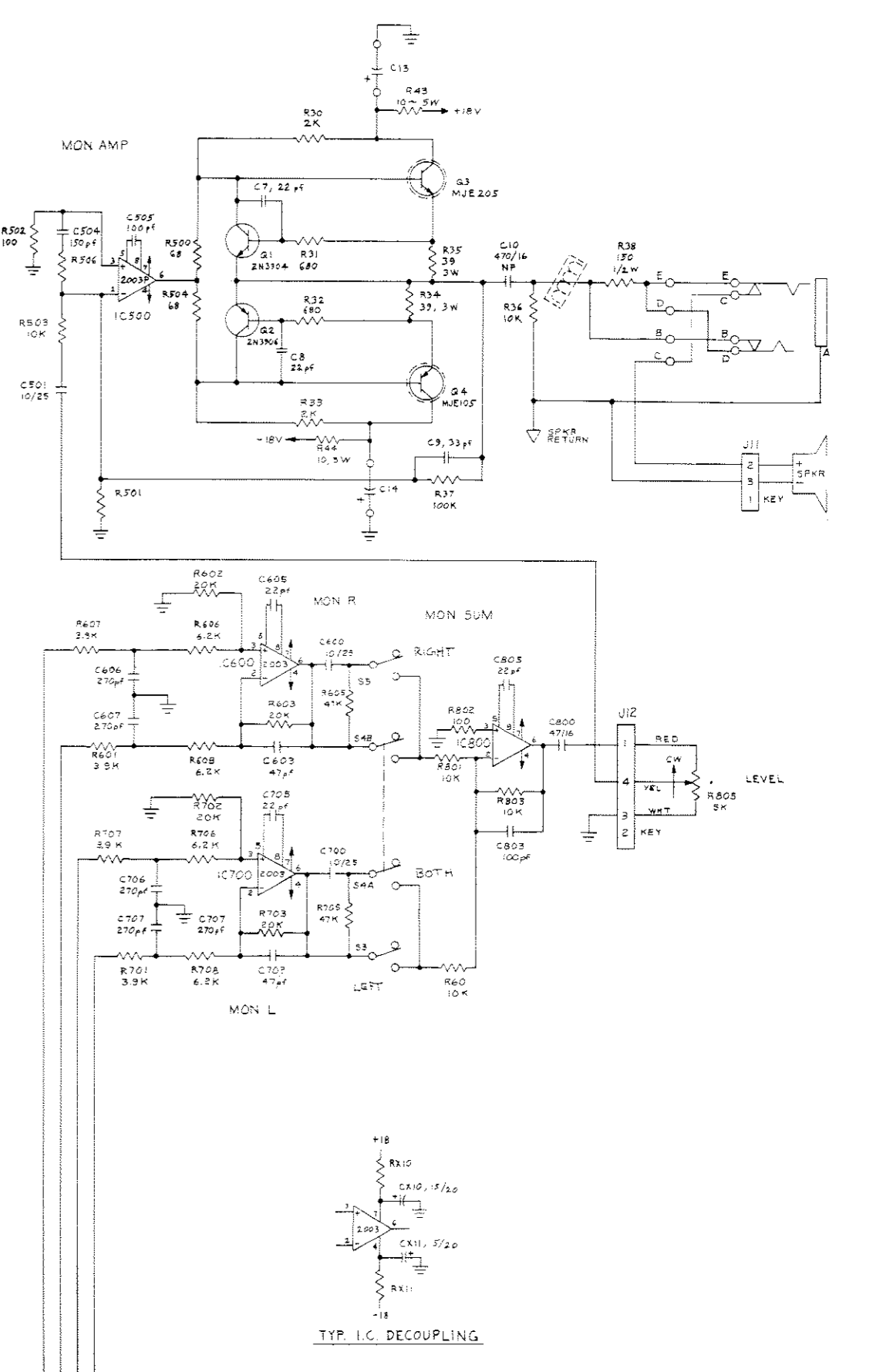

TYP. I.C. DECOUPLING

Broadcast Amp Board
SC27E080
JH-110 SERIES

Section 5

PARTS LIST
BROADCAST MONITOR AMP BOARD
PCA2700-0080

Molex connector, 3 pin locking	09-65-1031
Molex connector, 4 pin locking	09-65-1041
Molex connector, 5 pin locking	09-65-1051
Op-amp	TL084CN
Op amp	2003P
Transistor	2N3904
Transistor	MJE-105
Transformer	SP-7000-0110-00
Transformer	SP-7000-0193-00
Lamp holder	25-35
Potentiometer	TAPCPOT10K-1T
Switch	SP-7100-2307-06
Switch	SP-7100-2307-49

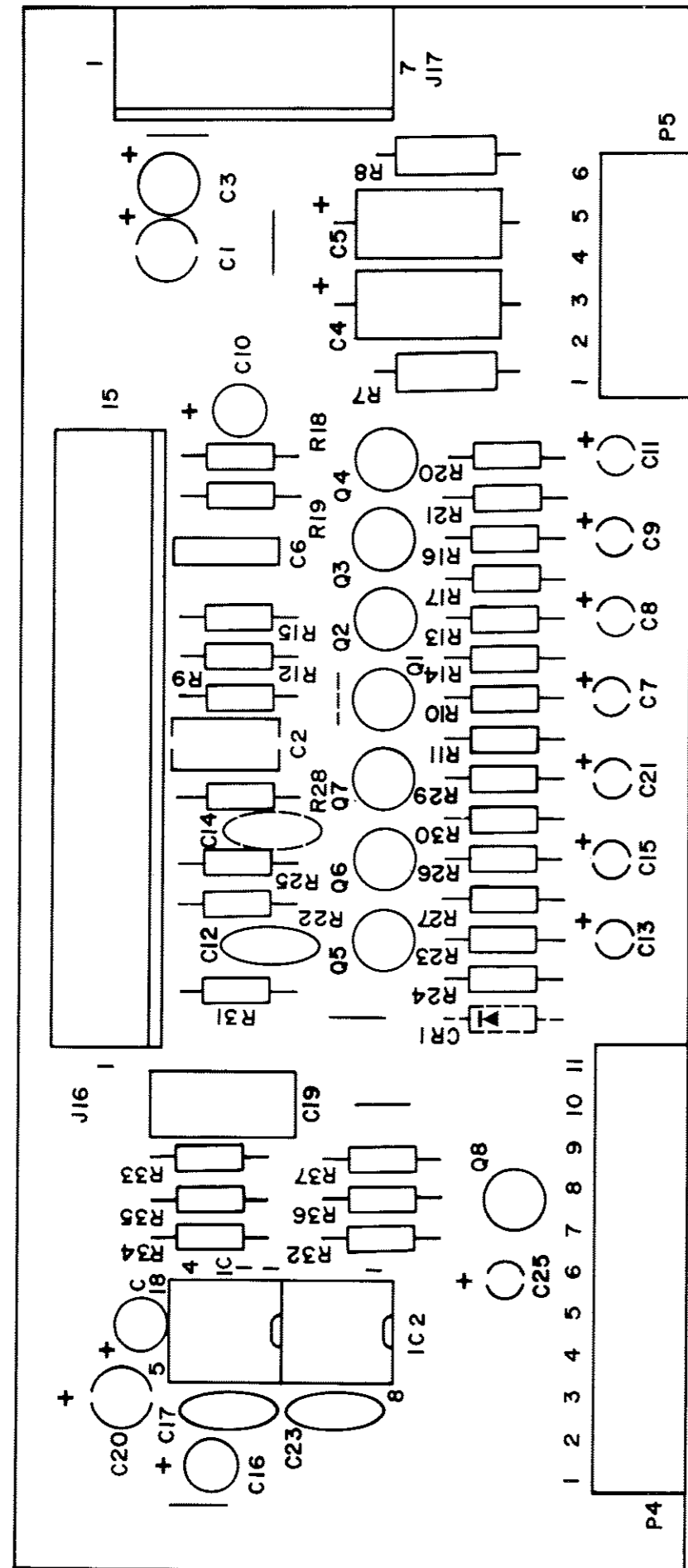

SS2700C0915-00 B
FRONT PNL EQ PC BD
JH-110 M

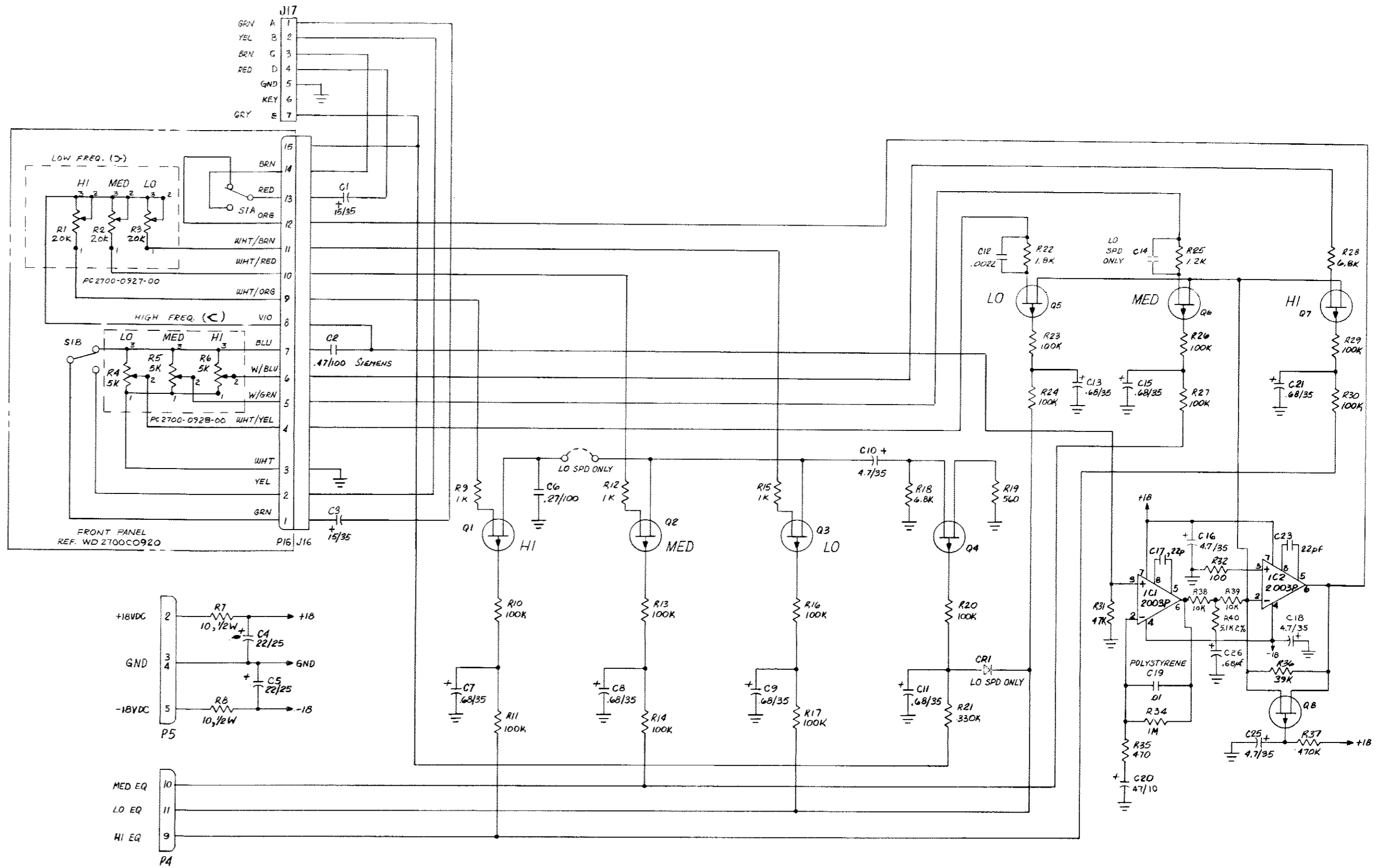

Front Panel EQ Board
SC27D915
JH-110 SERIES

PARTS LIST
FRONT PANEL EQ BOARD
PCA2700-0915-00

Right Angle Molex Connector 5CIR	09-52-3051
Right Angle Molex Connector 6CIR	09-52-3061
7 Pin Molex Connector	09-65-1071
8 Pin Molex Connector	09-65-1081
Tantalum Capacitor, DIP	15MF35V-CTA10
Op-Amp	2003P
Poly-Film Capacitor	2200PF100V-CPF
Metal Poly-Film Capacitor	27MF100V-CMPF
Metal Poly-Film Capacitor	47MF100V-CMPF
Tantalum Capacitor DIP	68MF35V-CTA10
Card Pull	MC-2700-0045-01
Front Panel EQ Label	MC-2700-0082-08
P Channel FET	P1086RR

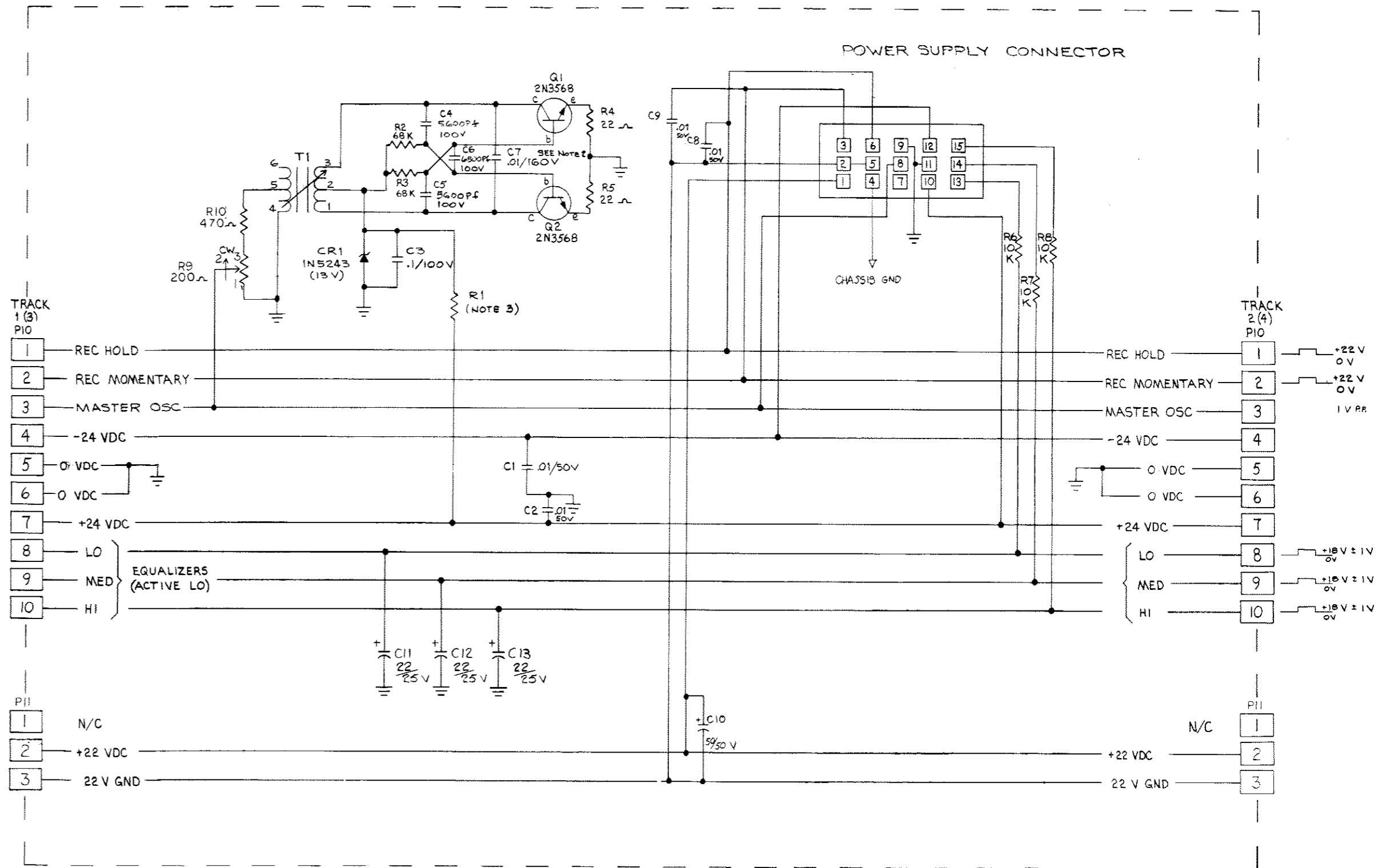
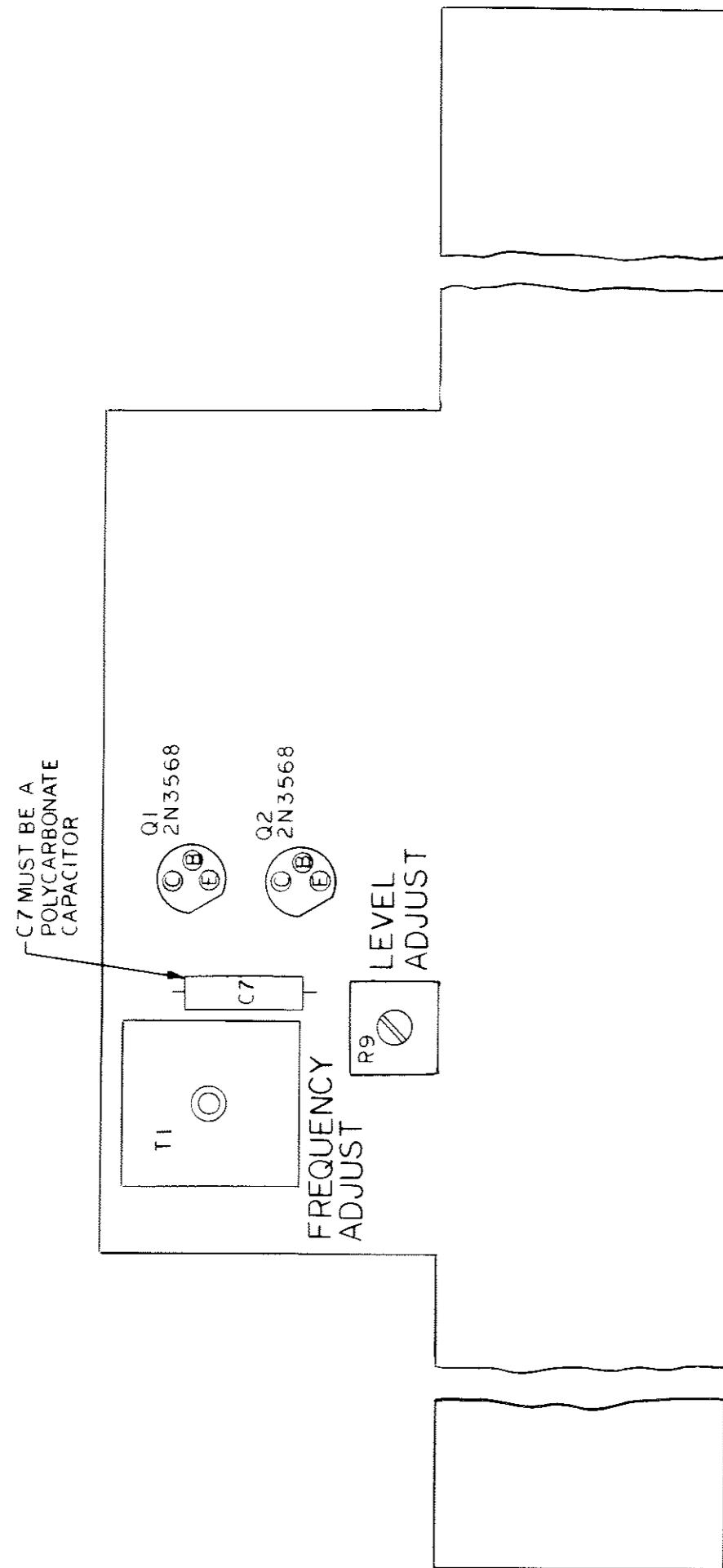

NOTE:
 1. UNLESS OTHERWISE SPECIFIED,
 ALL RESISTORS ARE 1/2W, 5%
 ALL CAPACITORS ARE IN MICROFARADS.
 2. C7 TO HAVE HIGH THERMAL STABILITY
 3. PCA 2700-0005-00
 R1 IS 220 Ω
 PCA 2700-0005-01
 R1 IS 100 Ω
 4. C4, C5 & C6 ARE CLTC TYPE CAPACITORS.

**PARTS LIST
STRIP BOARD
PCA2700-0005-01**

Molex Connector	02-06-7103
Molex Connector 15CIR	03-06-2151
2 Pin Molex Connector	09-64-1021
10 Pin Molex Connector	09-64-1103
10 Pin Molex Connector	09-64-1101
10 Pin Molex Connector	09-64-1103
Zener Diode	1N5243-13V
Bias Coil	D-1021-10
NPN Transistor	PN3568
Potentiometer	TAPCOT200-1T
Polycarbonate Capacitor	:01MF160V-CPCF

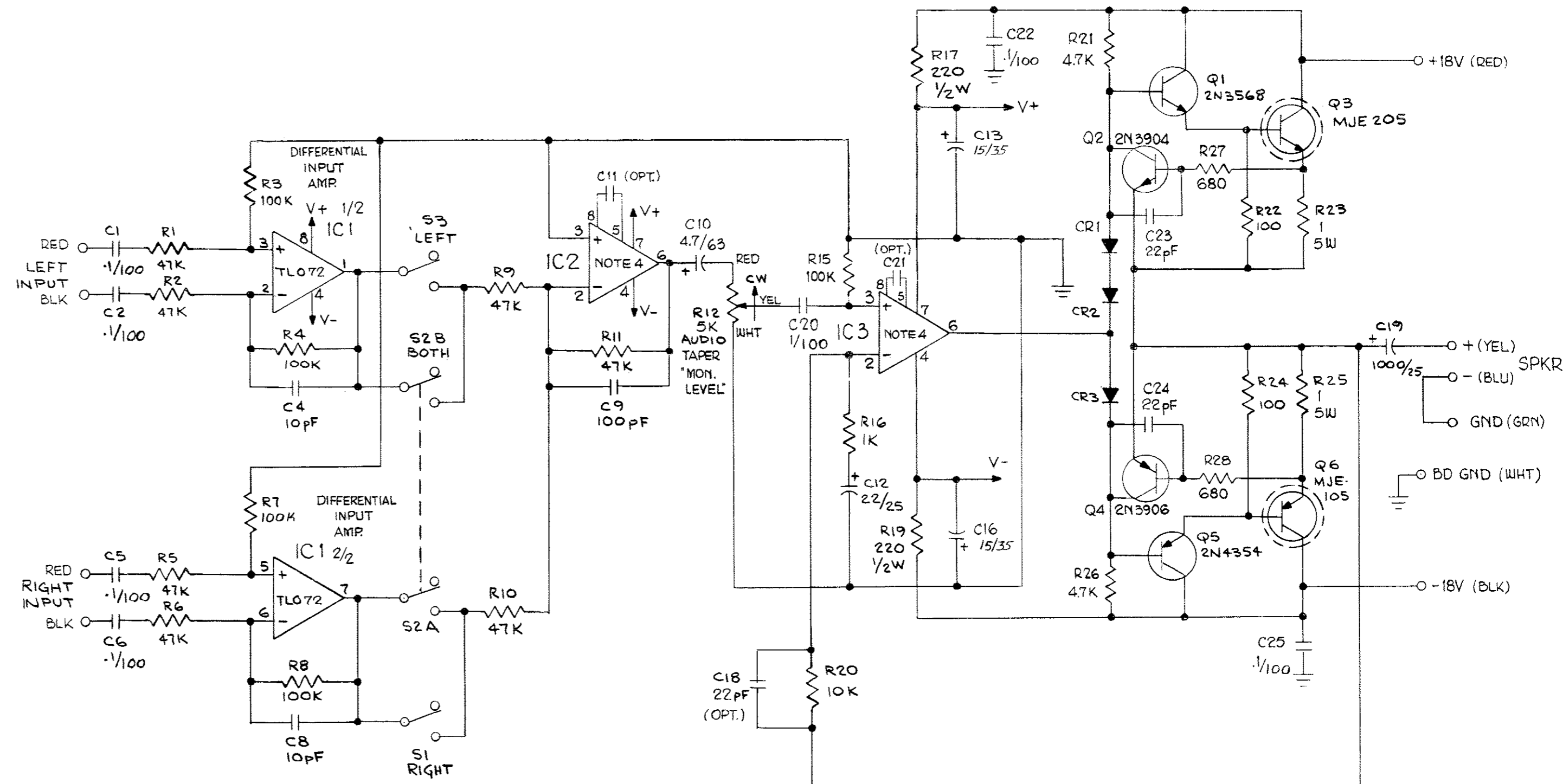
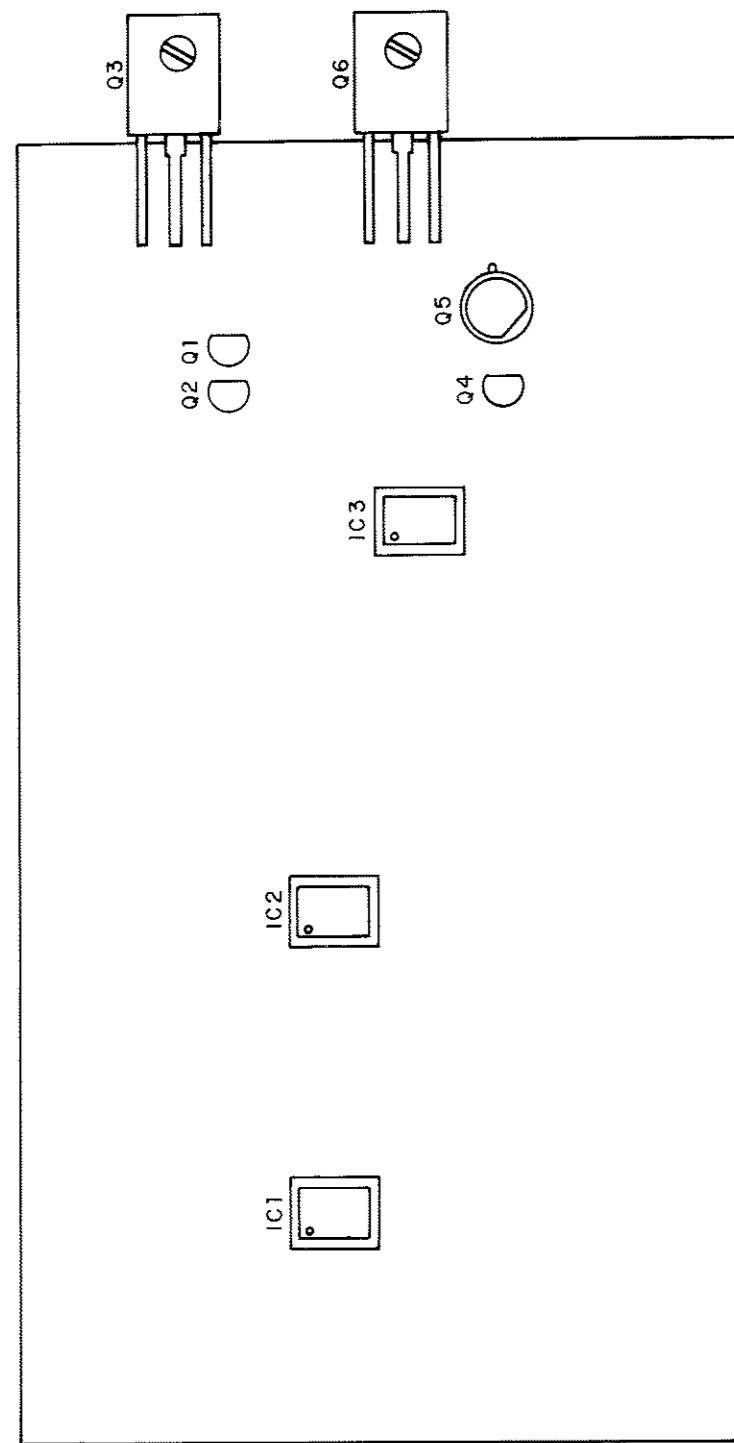

- NOTES:
- UNLESS OTHERWISE SPECIFIED:
 - 1. ALL RESISTOR VALUES ARE IN OHMS, 1/4W, 5%.
 - 2. ALL CAPACITOR VALUES ARE IN MICROFARADS.
 - 3. ALL DIODES ARE IN 914.
 - 4. IC2 & 3 ARE TL071; NE 5534 P CAN ALSO BE USED (THEN C20 & 21 ARE REQUIRED)

J3
MOLEX
09-65-1071

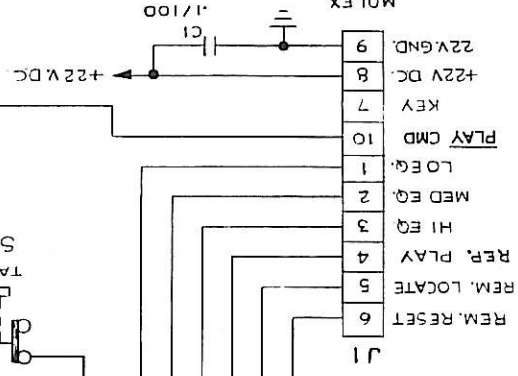
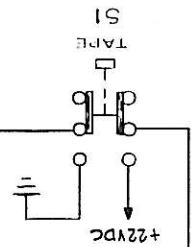
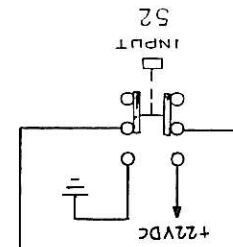
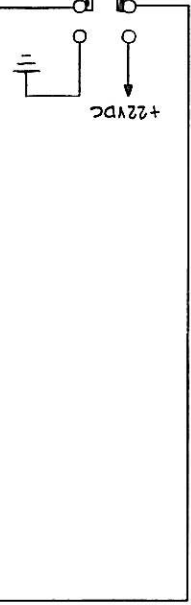
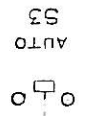
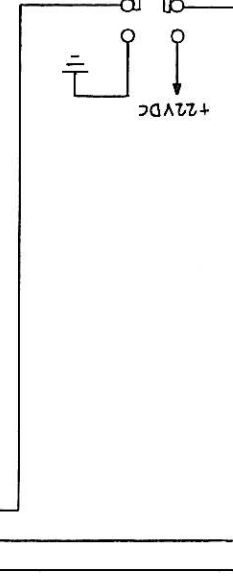
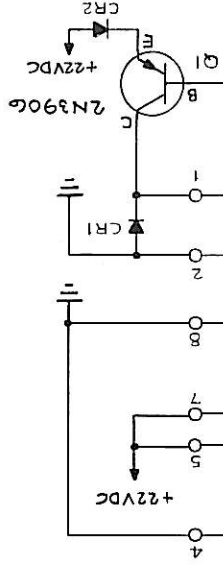
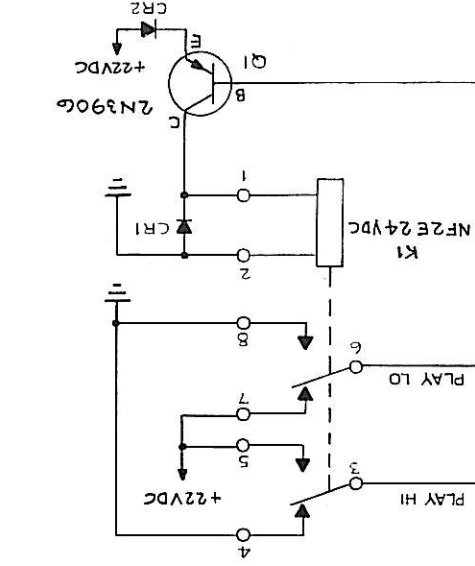
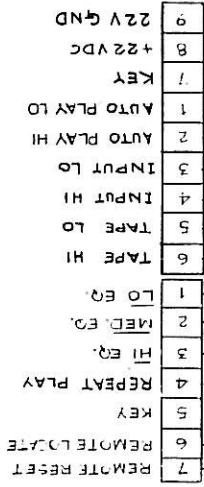

NOTE:
UNLESS OTHERWISE SPECIFIED:
1. ALL RESISTOR VALUES ARE IN OHMS 1/4W, 5%
2. ALL DIODES ARE IN 4004.
3. ALL CAPACITOR VALUES ARE IN MICROFARADS/VOLTS.
4. S1, S2 & S3 ARE SWA-0006, INTERLOCKED,
SHOWN IN "AUTO" MODE.

Remote Master Switching Board SC27C937

JH-110 Series

Section 5

Page 5-27

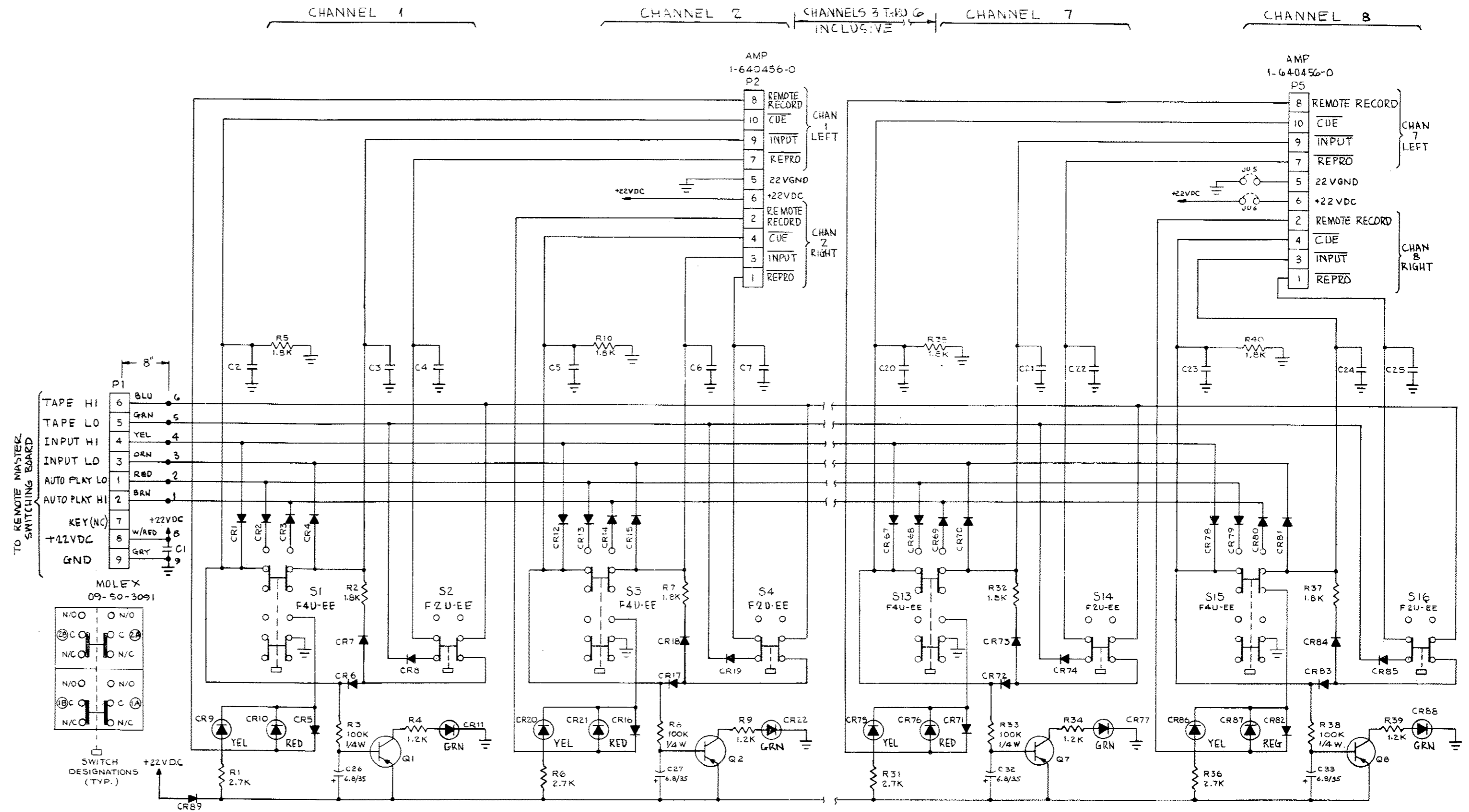
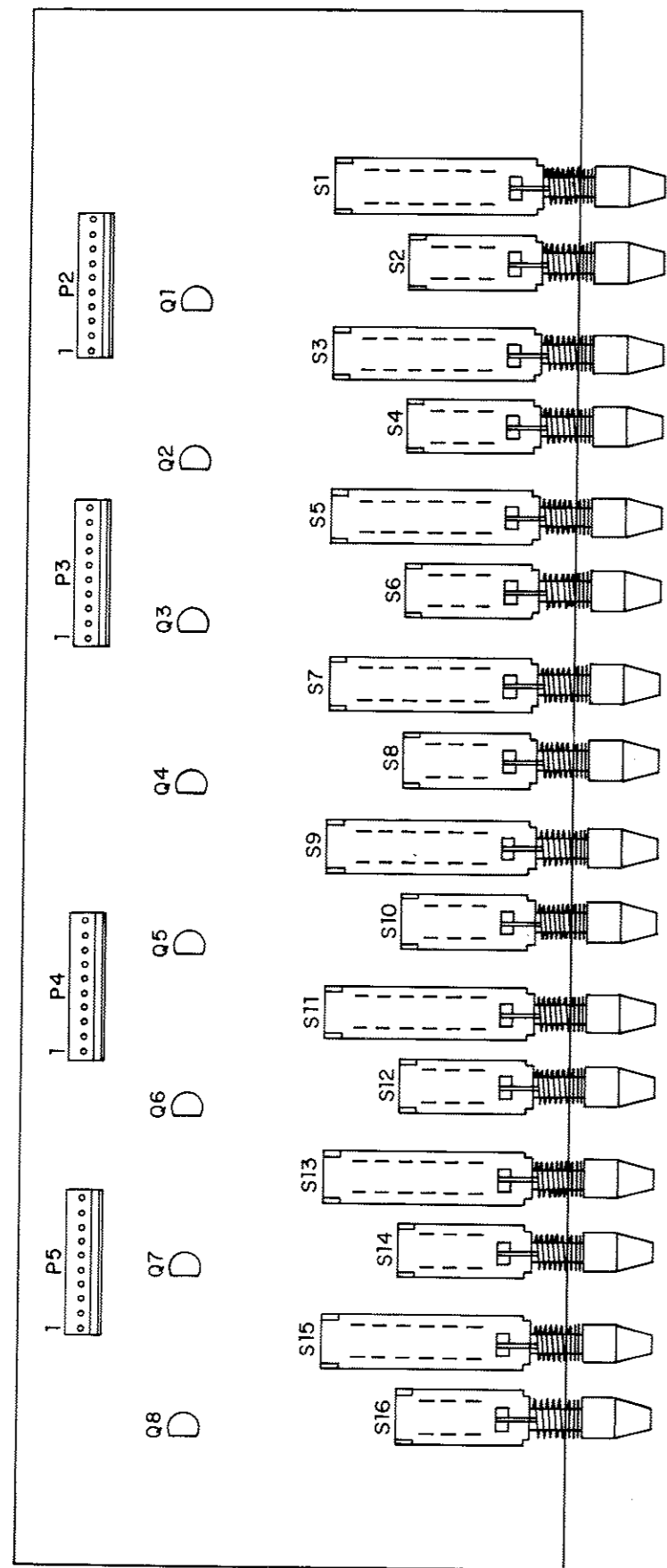

NOTES: UNLESS OTHERWISE SPECIFIED.

1. ALL RESISTOR VALUES ARE IN OHMS 1/2 W, 5%.
2. ALL DIODES ARE IN 4004.
3. ALL TRANSISTORS ARE 2N3906.
4. ALL CAPACITORS ARE .1 MICRO FARAD/100V.

5. GRN. LED'S ARE MV5274C OR EQUIVALENT.
6. RED LED'S ARE MV5074C OR EQUIVALENT.
7. YEL LED'S ARE MV5374C OR EQUIVALENT.
8. ALL WIRES ARE AWG#12 STRANDED.

Remote Channel Status Board
SC27D938 rev. C

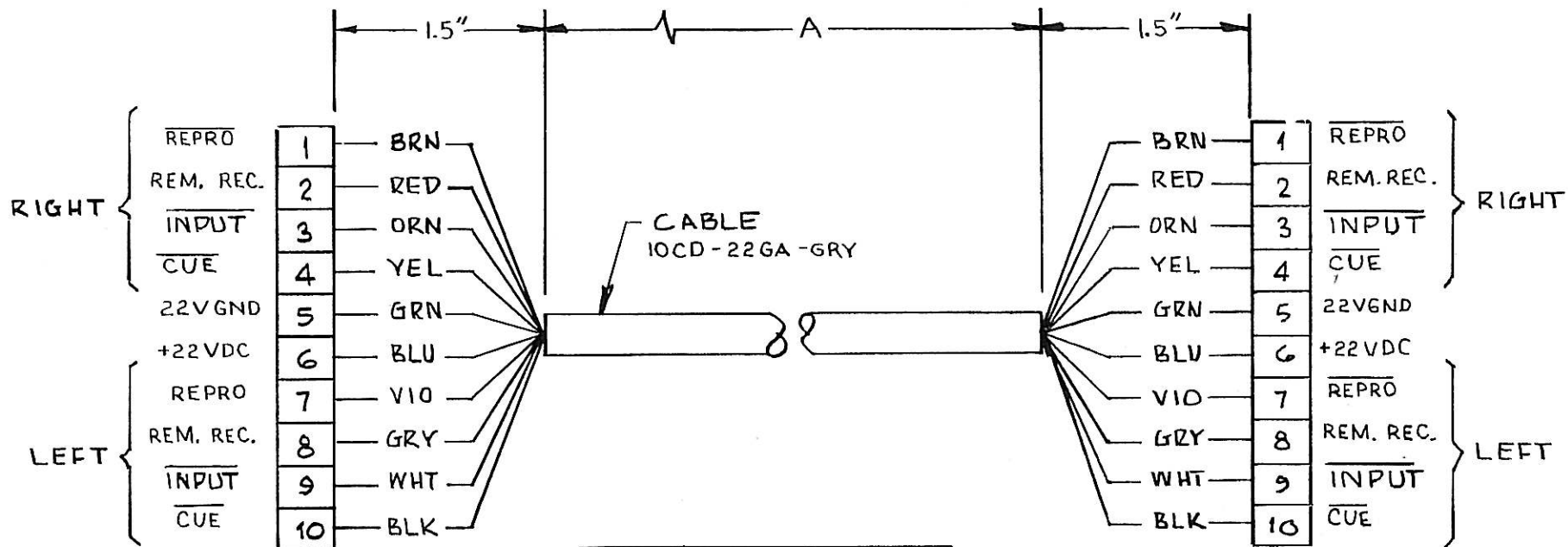

AMP
1-640440-0

BEAU
P3310-CCT

* DASH NO.	DIM A	JH-110C 8-TRACK CHANNEL USAGE
00	39' 11"	1-2
01	39' 5"	3-4
02	38' 10"	5-6
03	38' 4"	7-8

Remote Channel Status Cable

JH-110C
WDA27B932



P1

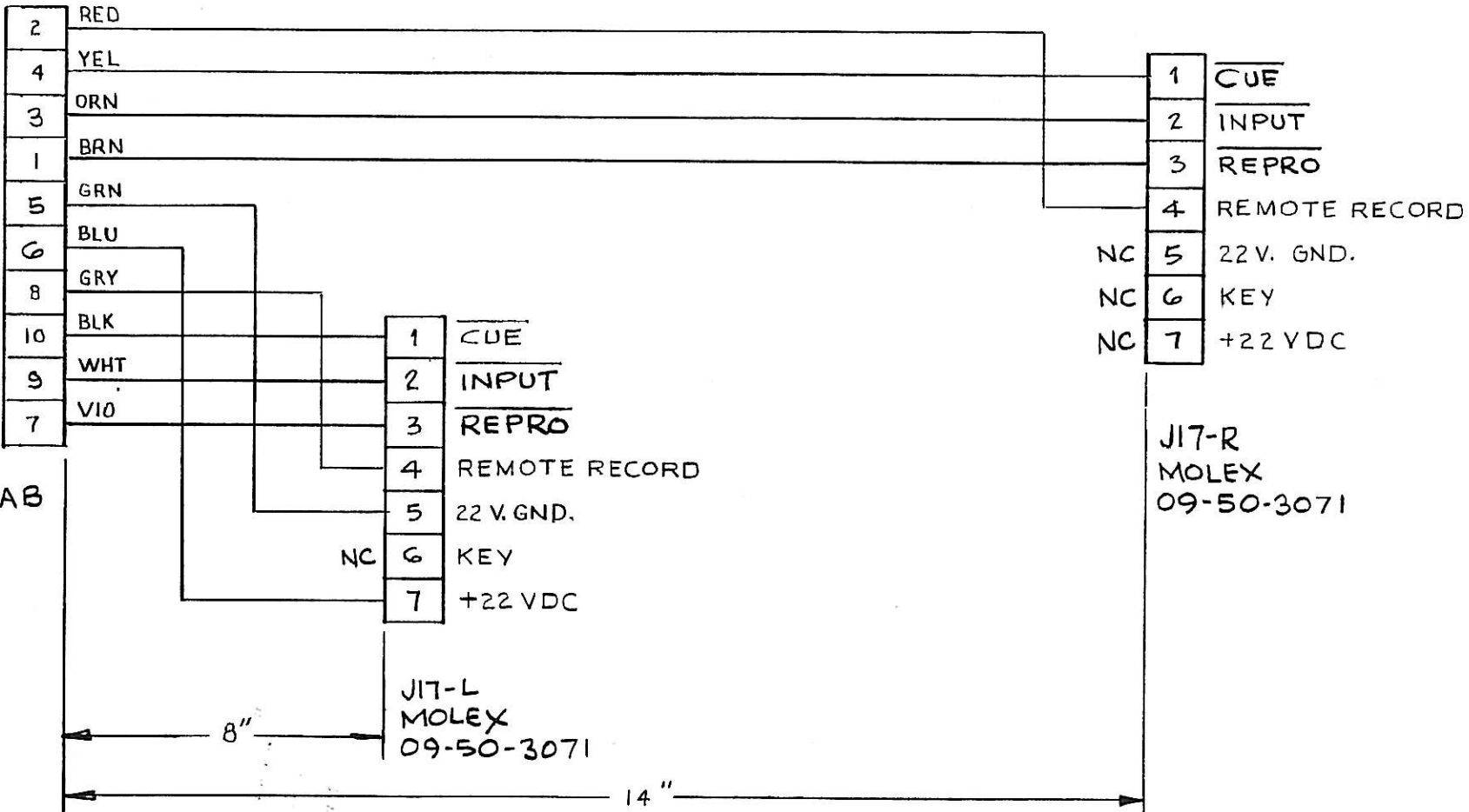

BEAU
S3310-AB

J17-R
MOLEX
09-50-3071

J17-L
MOLEX
09-50-3071

8"

14"

Audio Drawer Remote Harness

JH-110C

WDA27B931



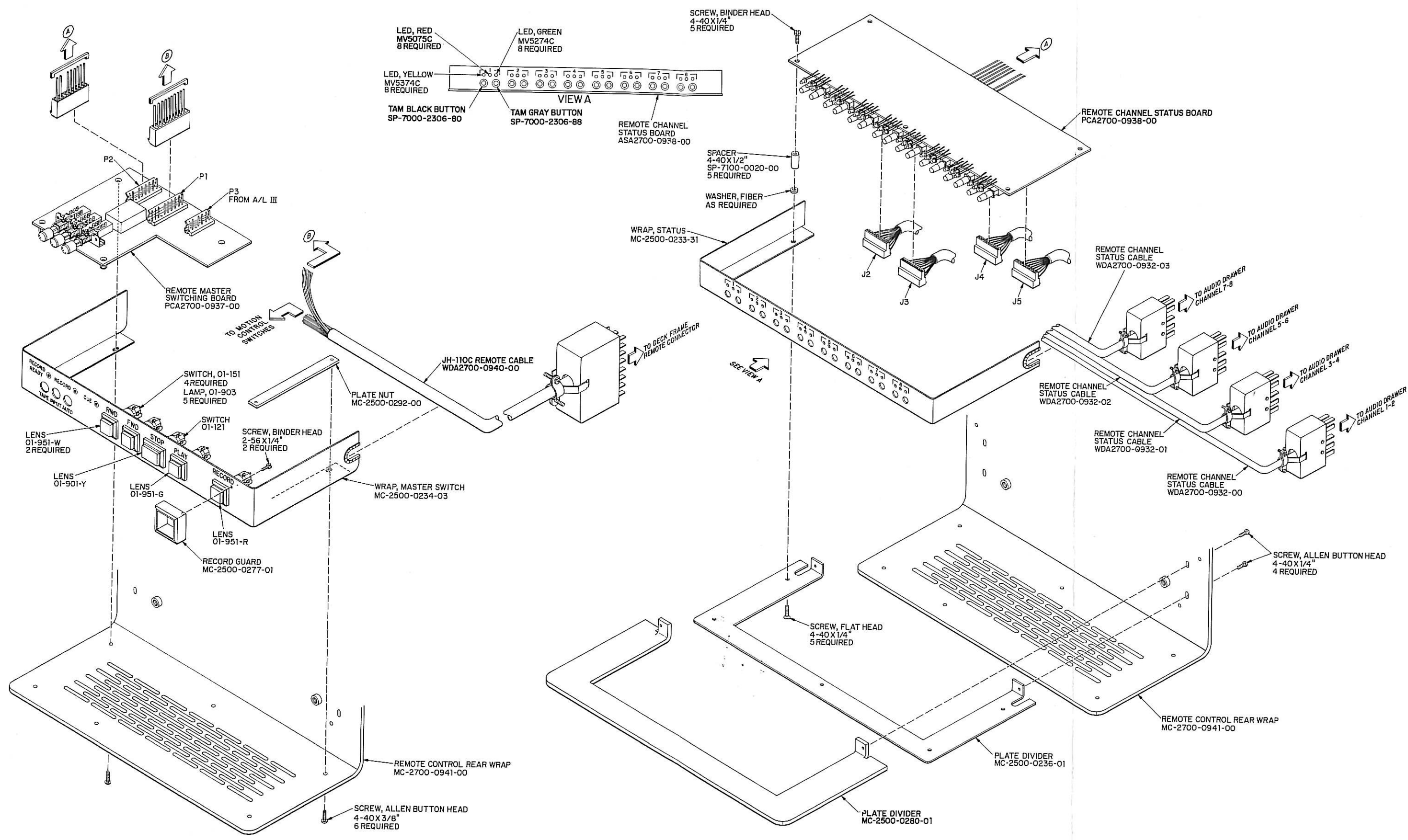

**Remote Control Assembly
TW27E080**

SECTION 6

POWER SUPPLY

6.1 General Description

The JH-110PS power supply mounts at the bottoms of both the variable profile cabinet and the high profile cabinet. All versions use the same power supply. Outputs from the power supply provide operating voltages for the transport, autolocator, and up to eight audio channels. Jumpers in the fuse holder adapt the power supply for use with either 100, 115, or 220vac, 50 to 60Hz. A four amp fuse is required for 100 and 115vac operation; a two amp fuse is required for 220vac operation.

Table 6-1 is a list of the regulated and unregulated voltage outputs and their use. The +18, +15, -18, and -15 volt regulators are located behind an

TABLE 6-1

VOLTAGE	WHERE USED
24VAC unregulated	MVC
+30VDC unregulated	Reel Motors
+8VDC unregulated	Transport +5 volt logic supply regulator
+22VDC regulated	Capstan motor, solenoids, LEDs, and lights
±18VDC regulated	Audio Amplifiers
±15VDC regulated	Transport Amplifiers

access cover on the front of the power supply chassis. The 22 volt regulators are located on the Motor Driver Board which is part of the chimney assembly.

6.2 Motor Driver Board

The Motor Driver Board mounts on top of a metal enclosure which is part of the fan assembly called the chimney. Two heat sinks for the reel motor drivers and 22 volt regulators fit inside the enclosure directly behind the fan. The chimney assembly is easily removed from the power supply chassis by turning four quick release fasteners.

The supply motor and take up motor driver circuits on this board are actually part of the tape tension servo system. Both reel motors connect to the unregulated 30 volt supply. The motor driver transistors, mounted on the heat sink, allow current to flow through the reel motors in response to commands from the Analog Torque Board.

There are presently two types of Motor Driver Boards in the field, a PCA2600-0027 and a PCA2600-0033. These boards are not interchangeable; they require different power supply chimney assemblies. The PCA numbers are screened on the boards. However, the easiest way to tell them apart is; the 0033 board has two adjustment potentiometers on it, while the 0027 board has none. The motor driver circuits on both boards are identical; the 22 volt regulators are different.

On the 0027 board, the 22 volt regulator circuit uses a 24 volt zener diode reference to control the output voltage. Current through the series pass

transistor, mounted on the heat sink, adjusts to compensate for load variations. Maximum current is limited by an overcurrent shunt.

On the 0033 board, there are two independent 22 volt regulators; one for the transport and one for the audio electronics. Regulation is performed by two monolithic regulators mounted on a heat sink.

6.3 Voltage Measurements and Adjustments

The regulated output voltages from the supplies using the 0027 Motor Driver Board are not adjustable. If a voltage output is unsatisfactory, components will have to be replaced.

For power supplies using the 0033 Motor Driver Board, only the 22 volt supplies are adjustable. Any other voltages which are out of tolerance indicate a component problem.

Measure the ± 18 volt and ± 15 volt regulated outputs by removing the access cover on the front of the power supply. Test points for each regulator output are located behind the access cover. The ± 15 volt supply tolerance is approximately ± 0.6 volts. The ± 18 volt supply tolerance is approximately ± 0.7 volts. Each of these four supplies should have no more than 5mv peak-to-peak ripple.

The 22 volt regulated supply should not vary by more than two volts. For supplies using PCA-2600-0027, measure this voltage on the Transport Mother Board from the rear of the cabinet. For supplies using PCA2600-033, measure these voltages by removing the chimney assembly from the chassis. If the supply's output is not 22 ± 2 vdc, perform the voltage adjustment.

Voltage Adjustment

1. Turn power off.
2. Remove the power supply chimney assembly.
Turn the four quick release fasteners.
Pull the chimney assembly out of the power supply.
Do not disconnect any of the cables.
3. Turn power on.
4. Connect the voltmeter's + lead to pin 12 of J1. Connect the voltmeter's - lead to either pin 14 or pin 15 of J1.
5. Adjust potentiometer R13 for a meter reading of +22vdc.
6. Connect the voltmeter's + lead to pin 10 of J1.
7. Adjust potentiometer R10 for a meter reading of +22vdc.
8. Turn power off.
Remove the voltmeter leads.
9. Replace the chimney assembly in the power supply.

Two 5 volt regulators for the deck logic and RTZ logic are mounted on the frame supporting the Transport Mother Board. These regulators produce 5 volts from the eight volt unregulated supply. Measure these TTL supplies at the regulators.

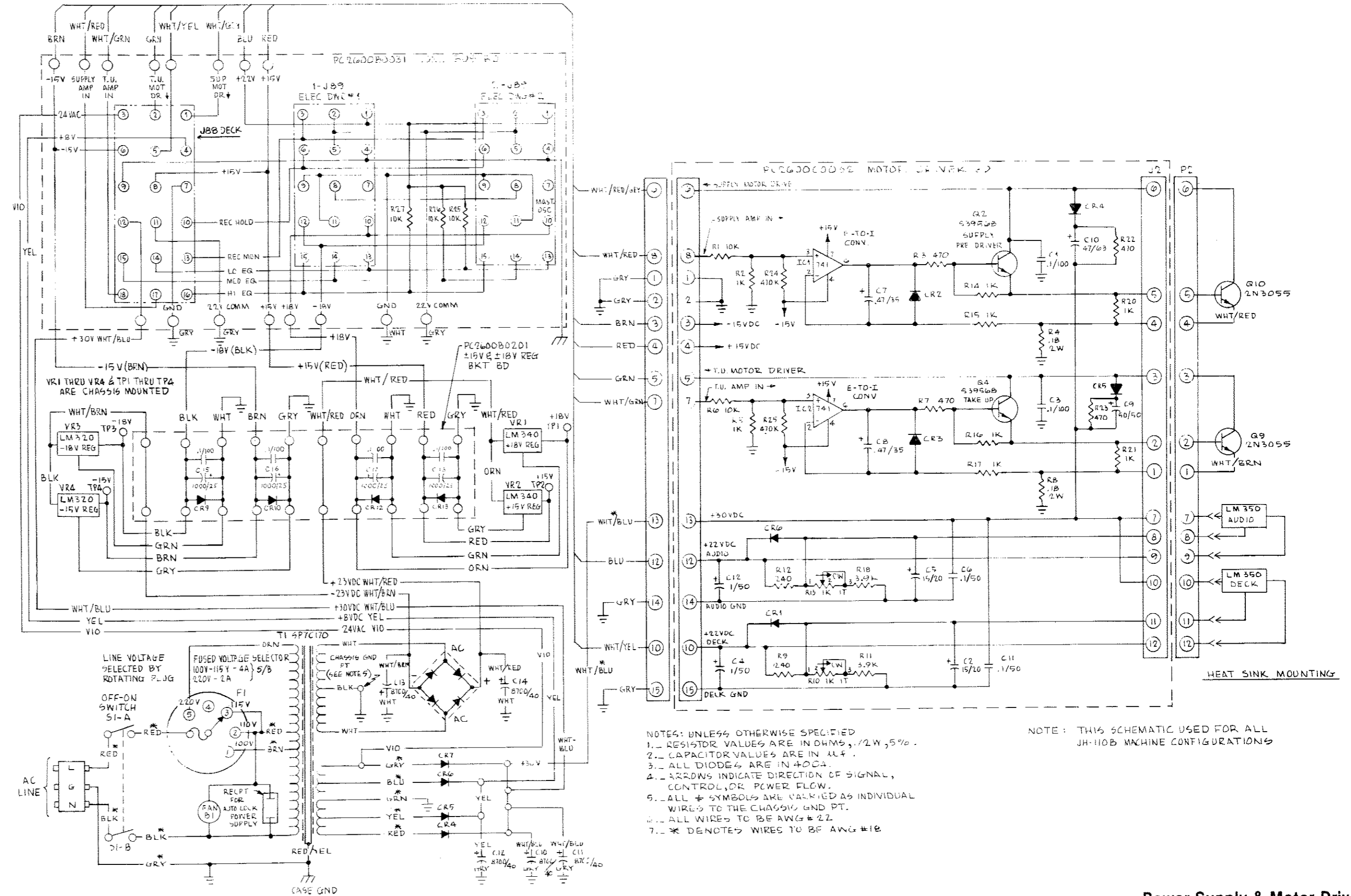
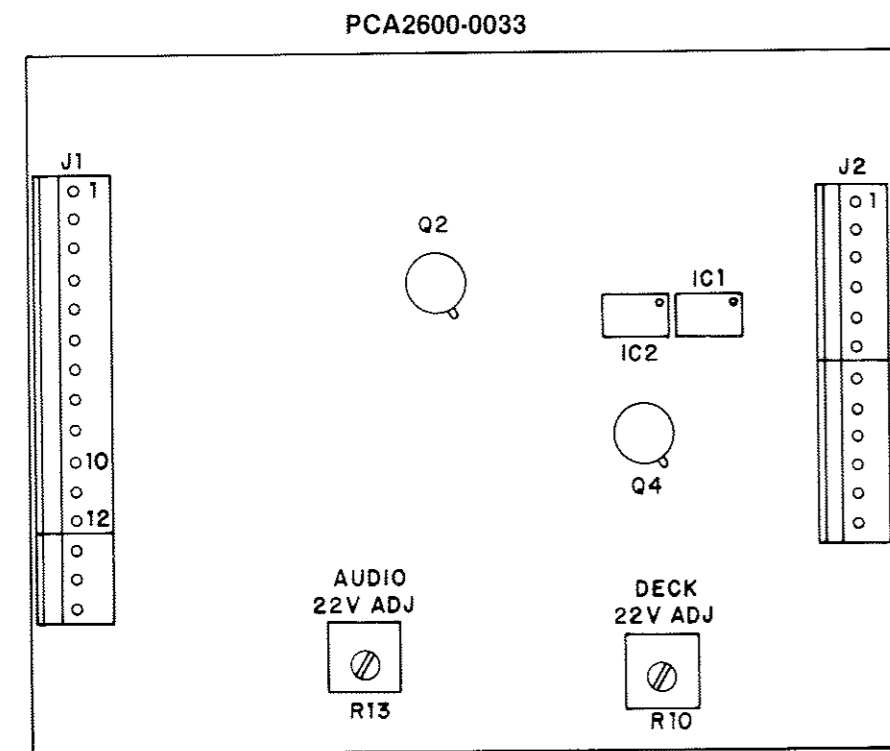

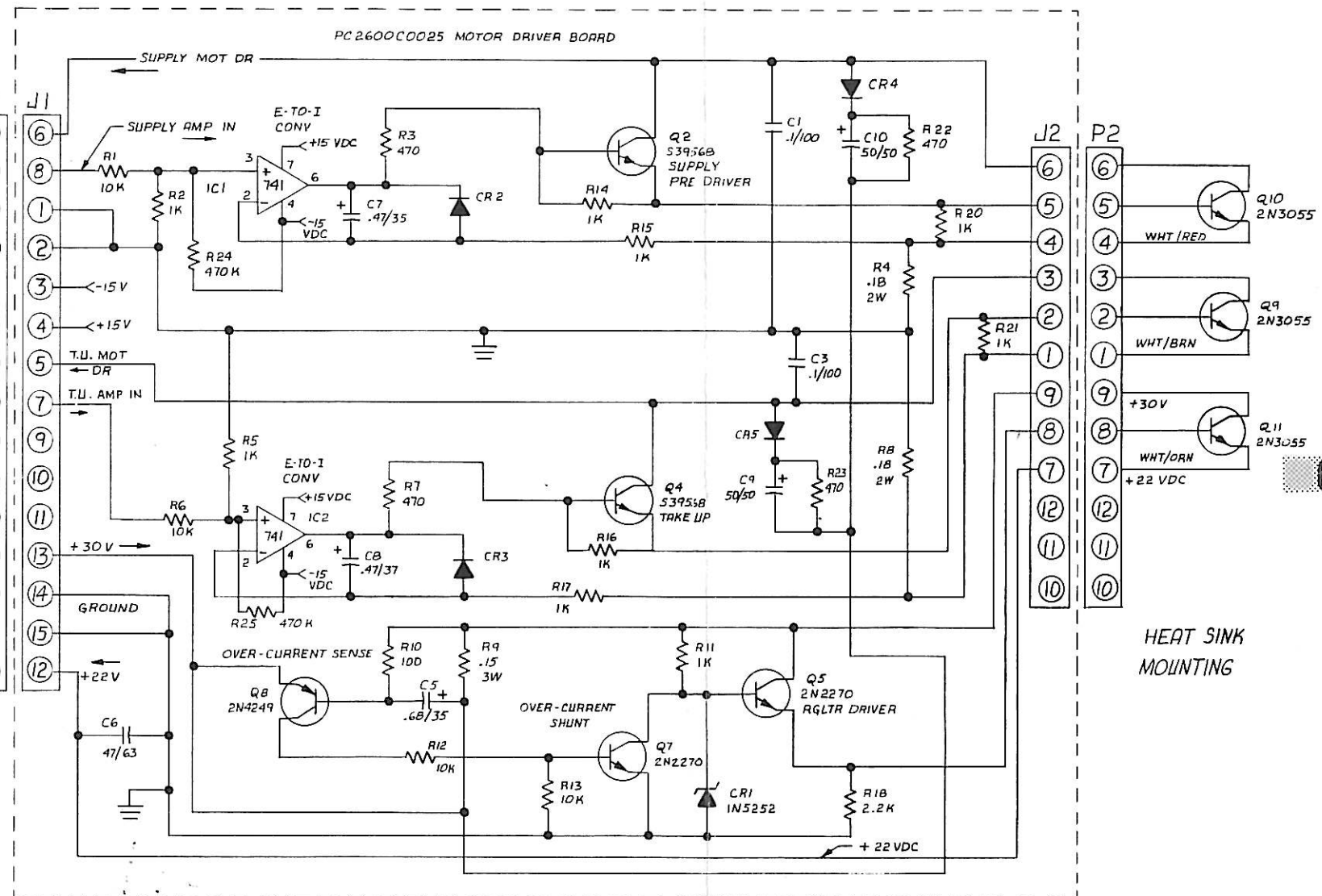
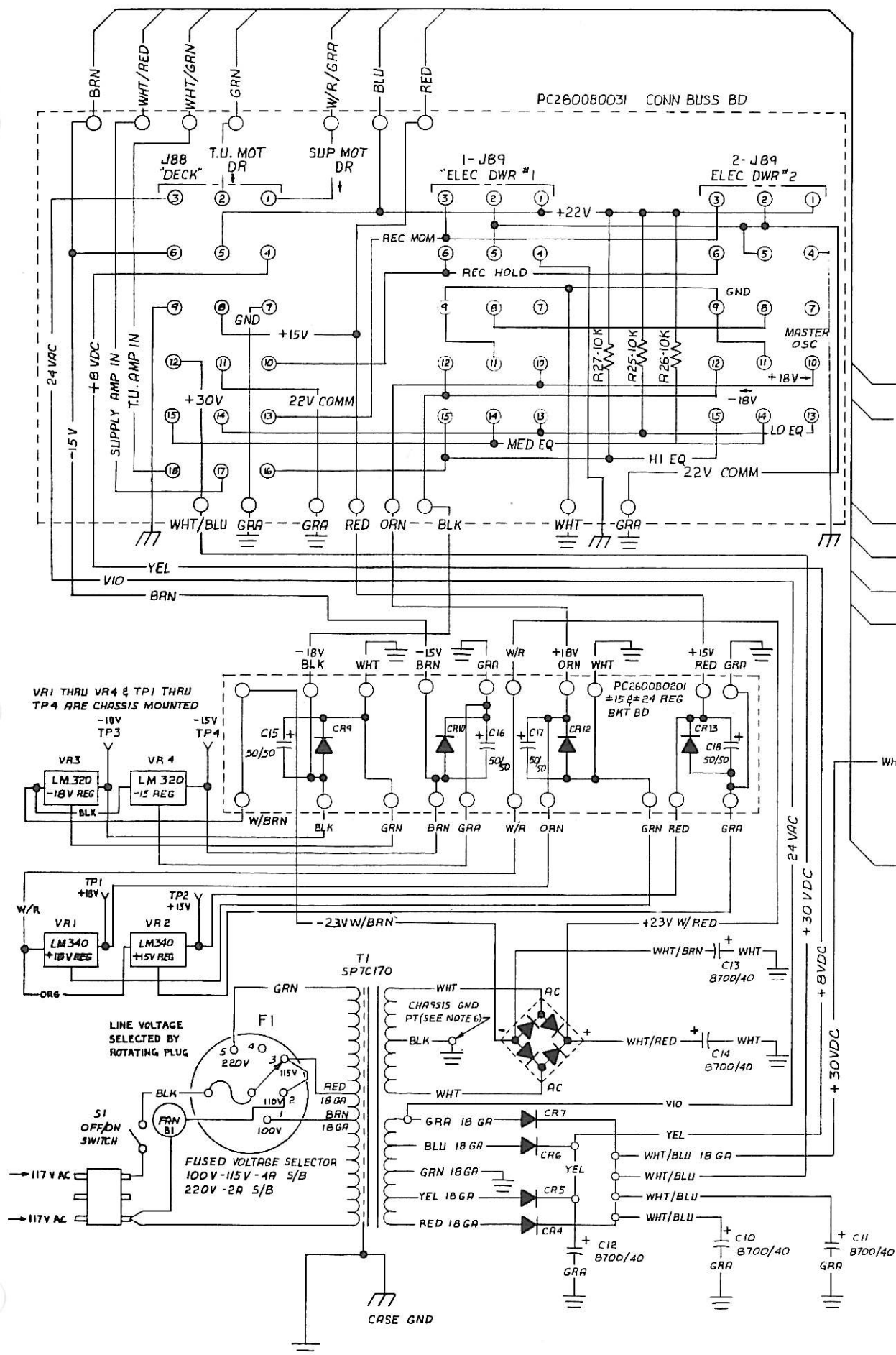

- NOTES: (UNLESS OTHERWISE SPECIFIED)
1. RESISTOR VALUES ARE IN OHMS, 1/2 W, 5%.
 2. ARROWS INDICATE DIRECTION OF SIGNAL, CONTROL, OR POWER FLOW.
 3. CAPACITOR VALUES ARE IN MICROFARADS/VOLTS.
 4. TP1, 2, 3, 4 LOCATED ON FRONT PANEL UNDER REGULATOR ACCESS COVER.
 5. WIRE IS 22 GA.
 6. ALL + SYMBOLS ARE CARRIED AS INDIVIDUAL WIRES TO THE CHASSIS GND PT.
 7. ALL DIODES ARE 1N4004.

Power Supply & Motor Driver Board
SC26D027

PARTS LIST
POWER SUPPLY
ASA2600-0027-04

6 Hole Cable Connector	09-50-3061
NPN Power Transistor	2N3055-H
Rectifier Diode	1N4721
Bridge Rectifier	250JB2L
Power Transformer	SP-7000-0170-00
-15 Volt Regulator	LM320KC-15
+15 Volt Regulator	LM340KC-15
-18 Volt Regulator	LM320KC-18
+18 Volt Regulator	LM340KC-18
Rectifier Diode	MR-752
3 Pin Molex Connector	09-65-1031
12 Pin Molex Connector	09-65-1121
Rectifier Diode	1N4004
Zener Diode 24 Volt	1N5252B-24V
NPN Transistor	2N2270
PNP Transistor	2N4249
NPN Transistor	2N5681-S39568
Op-Amp	TL081CP

SECTION 7

MAINTENANCE

7.1 Equipment Needed

MCI uses the following equipment to test and align its tape recorders. Your recording equipment must be periodically aligned to insure optimum performance. Carefully adhere to the following procedures, using the specified test equipment or test equipment of equal accuracy. Remember that the quality of the recording depends on the accuracy of the alignments. Verify the tape transport and audio alignments at least once a week to insure peak performance. Clean and demagnetize the heads before every recording session.

CAUTION

Never clean the scrape flutter filter with head cleaner or alcohol. These solvents dissolve the lubricants in the jewel bearings and will eventually damage the assembly.

AC Voltmeter capable of reading at bias frequencies of 120 KHz
Hewlett-Packard Model 400FL

DC Voltmeter, electronic type, 0.3 volt, full scale
Triplet Model 603

Audio Signal Generator
Krohn-Hite Model 5800

Frequency Counter
Hewlett-Packard Model 5381A

Flutter Meter
EMT Model 424

Intermodulation Analyzer
Crown model 1MA

Wave Analyzer
Hewlett-Packard 3581A

Phase Meter
MCI Model JH-22

Spring Scales
Ametex 0—36 ounces (1.02 kgm) and 1—10 pounds (4.54 kgm)

Oscilloscope
Phillips Model 3232 (2 mv/cm vertical sensitivity, 10 mHz bandwidth, 0.2 microseconds/cm horizontal sweep)

7

NOTE:

Never use any type of shielded leads for scope or meter when working with the 120 KHz Bias Oscillator, detuning and/or wrong readings will always occur. Use only open leads not more than 3 ft. long.

The following service aids are available from MCI Customer Service Department:

ALIGNMENT KIT (surface blocks and height gauges) MCI number AS6B79
EXTENDER BOARDS

Reproduce board MCI number 27B51
Record board MCI number 27B52
Bias board MCI number 27B53

LOGIC ANNUNCIATOR BOARD MCI number 25B177

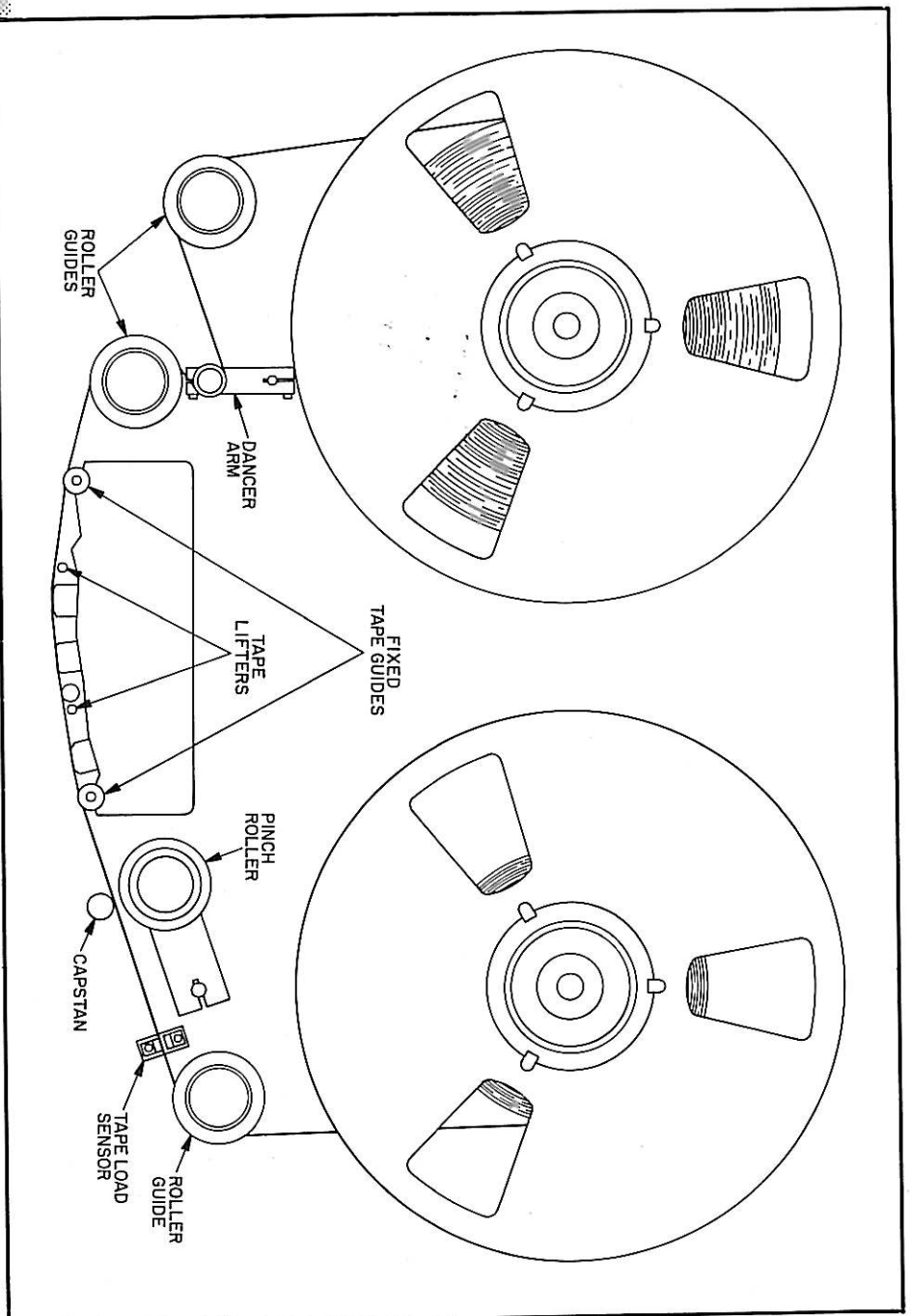

Figure 7-1 Tape Path

7.2 Tape Path Adjustments

The Mechanical Tape Path is critical. Tapes recorded on a misaligned deck will not playback properly on any other deck. Adjusting the tape path corrupts all the other alignments. The tape path is relatively stable and will rarely require adjustment under normal use; however, check the alignment periodically.

CAUTION

Improperly slit tape can make a properly aligned tape path appear to be out of alignment. Carefully select the roll of tape used in this procedure.

7.2.1 Turntable Height

TEST

Observe the spooling of the tape on the take up and supply reels. Tape should not rub against either reel flange; it should be centered between the two flanges.

Load a roll of tape. Use metal reels, insure that they are neither bent nor deformed.

Using the MVC Joystick, shuttle tape in both directions. Observe tape build up on each reel. Tape should not touch reel flanges. Release MVC Joystick.

Press FWD and observe tape, then, press RWD and observe tape. Tape should not touch reel flanges. Press STOP.

If Adjustments Are Necessary

If the tape is not centered between the take up reel and supply reel flanges, raise or lower the turntable to center the tape. Turntable height is adjusted by adding or removing shims between the turntable and the reel motor.

To adjust turntable height:

- Remove tape reel
- Remove reel hub
- Remove three screws securing turntable
- Remove turntable
- Install or remove shims to add or subtract required height
- Replace turntable, screws, and hub
- Load a reel of tape and repeat above test

The following die-cut shims are available from Customer Service:

26B22-1	(Blue)	0.005 inch/0.127 mm
26B22-2	(Brown)	0.010 inch/0.254 mm
26B22-3	(Yellow)	0.020 inch/0.508 mm

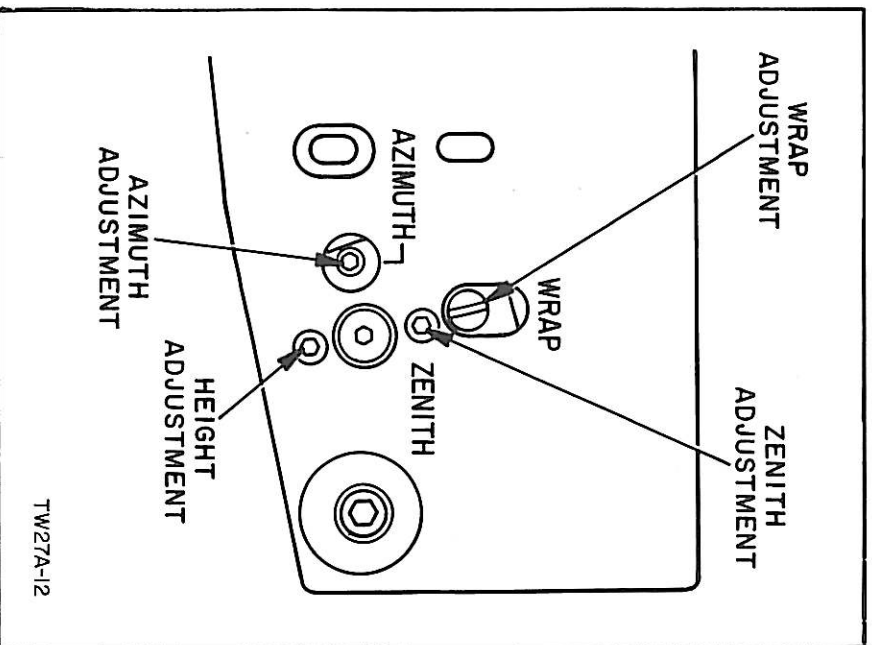

Figure 7-2 Head Adjustments

7.2.2 Head Height

Test

Check the head height, the heads must be centered in the tape path.

Press PLAY.

Observe the tape movement across the heads. Tape should be centered between the two "gutters" (edge slots) machined into the record and repro heads. On the erase head, you should see equal amounts of darker metallic material above and below the tape.

If Adjustments Are Necessary

If the tape is not centered between the gutters of the repro or record heads or centered over the erase head, turn the corresponding height, ZENITH, and AZIMUTH adjustment screws to center the head.

Turn the height adjustment clockwise to raise the head, counter clockwise to lower the head. Note that this screw moves the front of the head only. Turn the ZENITH adjustment the same number of turns in the same direction. This will raise or lower the back of the head. Turn the AZIMUTH adjustment in the opposite direction to compensate the tilt created by changing the height.

7.2.3 Head Zenith

Test

Check the Head Zenith alignments, head surfaces must be parallel to the fixed tape guides.

Loosen the two screws which secure the head assembly through the center of each fixed tape guide.

Remove the head assembly by pulling it straight up from the deck plate.

Hold the head bridge assembly in such a way as to visually align the repro head behind the right hand fixed tape guide. The repro head surface should be parallel to the fixed guide.

Visually align the record head behind the repro head. The record head surface should be parallel to the repro head surface.

Visually align the erase head behind the record head. The erase head surface should be parallel to the record head surface.

If Adjustments Are Necessary

If any head is not parallel to the fixed tape guide, turn the ZENITH adjustment screw, tilting the head until the surfaces are parallel.

7.3 Capstan Pinch Roller

Test

Check the Capstan Pinch Roller tension using a spring scale. The pinch roller should exert a 5 to 6 pound force against the capstan.

Attach the spring scale to the pinch roller shaft under the roller wheel.

Turn the transport power on and insert an opaque card in the tape sensor slot.

Press PLAY.

Press your finger lightly against the pinch roller.

Pull the spring scale toward the rear of the tape deck. Note the scale reading just as the pinch roller begins to slip. Scale should read between 5 and 6 pounds (approximately 2.5 kgm).

If Adjustments Are Necessary

If the tension is not between 5 and 6 pounds, adjust the lock nut at the end of the solenoid pull rod. Unlatch and open the transport deck plate. Turn the lock nut only a fraction of a turn and recheck the tension. Repeat until tension is within tolerance.

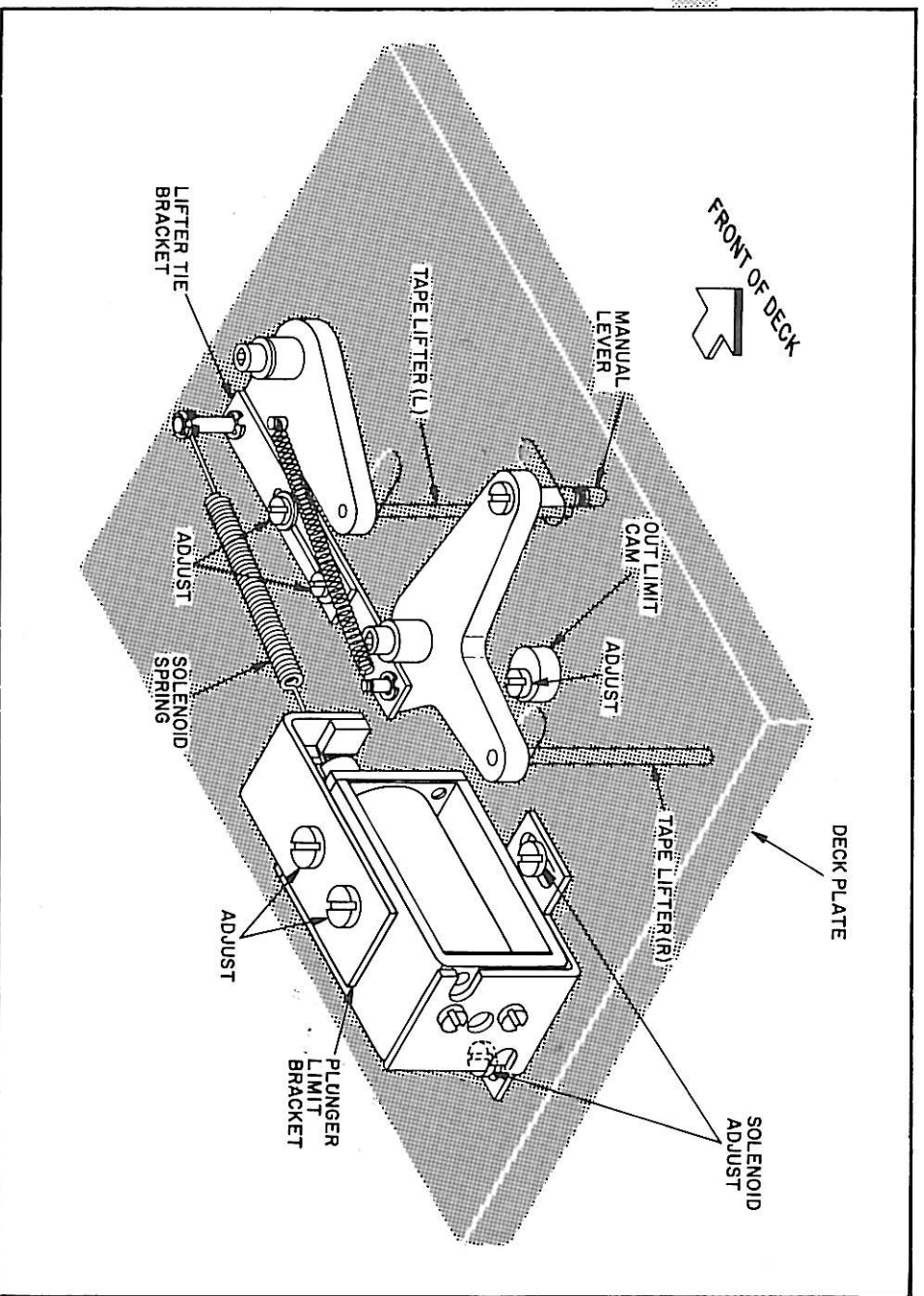

Figure 7.3 Tape Lifter Assembly

7.4 Tape Lifter

Test

1. Load a roll of tape. Put the transport into FWD or RWD mode. Observe the tape clearance at the heads.

Tape should clear the record head and the reproduce head by .050 in. (1.25 mm) which is about the thickness of a dime.

Tape may be much closer to the erase head. It is permissible for the tape to very lightly touch the erase head or to just clear it.

Observe the fixed tape guides at the entrance and the exit of the head block. Tape should ride through the slots without skew or crinkling.

NOTE:

Skewing and crinkling may occur if the tape lifters are adjusted for too much outward travel.

2. Put the transport into Stop mode. Tape lifters should move to their inward position.

Clearance between the tape lifters and the tape should be from .010 to .015 inches. The clearance at both pins should be equal.

If Adjustments Are Necessary

With tape loaded, put the transport into Stop mode.

1. Adjust the clearance between the tape and the reproduce head.

Hold the manual tape lifter pin all the way to the left. Adjust the OUT LIMIT CAM.

Clearance between the tape and the reproduce head should be .060 \pm .010 inches.

2. Adjust the clearance between the tape and the erase head.

Hold the manual tape lifter pin all the way to the left. Adjust the length of the lifter tie bracket.

Set the bracket length so that the tape barely clears the erase head.

3. Adjust the solenoid position.

Put the transport into FWD or RWD mode. The solenoid will pull in. Check that the solenoid spring is slightly stretched. Adjust the solenoid position if necessary.

NOTE:

If the spring is too tight, the solenoid will not seat properly. After the adjustment, switch from STOP mode to FWD mode several times and check that the plunger is moving in and out freely.

4. Adjust the tape lifter inward position.

Put the transport into Stop mode. The plunger limit bracket limits the inward travel of the tape lifters.

Adjust the plunger limit bracket so that the left tape lifter clears the tape by .010 to .015 inches (.3 mm to .4 mm).

Check that the right tape lifter clears the tape by the same amount as the left tape lifter, the two lifters must have the same clearance.

If the two clearances are not alike, the lifter tie bracket has not been properly adjusted. Go back to Step 2 of this procedure.

7

7.5 Dancer Arm Flutter Filter

7.5.1 Air Dashpot Dancer Arm

Test

Dancer arm position depends partially on proper tape tension. Any change of reel motor adjustments will affect the normal position of the dancer arm.

1. Load a roll of tape. Shuttle half of the tape to the takeup reel, so that the tape load is balanced between the two reels.

The normal position of the Dancer Arm, in Play or Record mode, should now be near the center of its travel arc.

2. Put the transport into Stop mode. The dancer arm will rest near the right end of its travel arc.

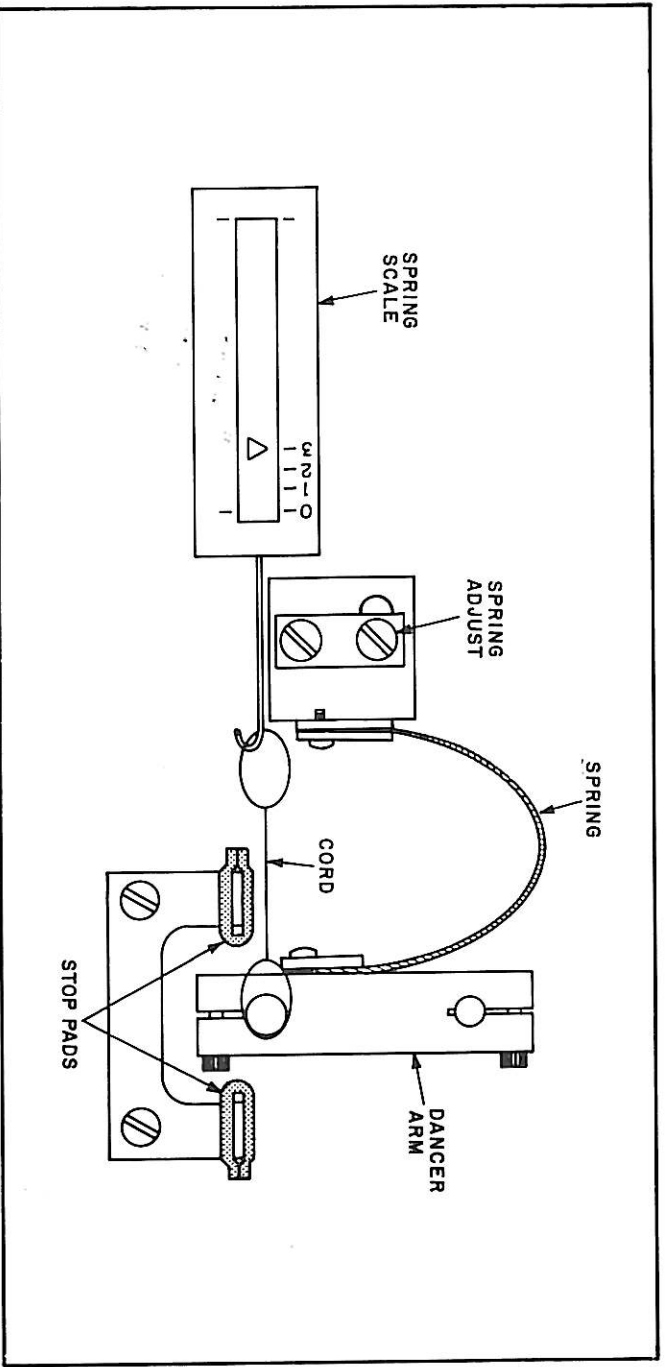

Figure 7-4 Dancer Arm Assembly

Illuminate the dancer arm well enough to see its small movements.

Put the transport into Play mode. Observe the transition from Stop to Play mode several times. The arm should swing to the left — just touch the left end stop — then swing back to its normal center position.

3. The return to center position after touching the left end stop is controlled by the air damper adjustment.

If the system is underdamped, the dancer arm will overshoot its normal center position, and then return to center. The arm movements will be quick and relatively large. The dancer arm is not damping the small, quick tape movements which contribute to flutter.

If the system is overdamped, the dancer arm will be sluggish in its return to its normal center position. Two faults may be visible:

- A. The tape may lose contact with the dancer arm for a fraction of a second while the arm is returning to center position.
- B. The dancer arm may bounce back toward the left before it reaches its normal center

position. When the pressure in the air cylinder is momentarily high enough to overcome the mechanical spring tension.

The dancer arm is too sluggish to follow the small, quick tape movements which contribute to flutter.

The damping should be very close to critical. Critical damping can be defined as moving to its new position as quickly as possible without overshoot or oscillation.

If Adjustments Are Necessary

CAUTION

The following procedure requires sensitive fingers and careful visual judgments. The air damper adjustment requires a skill which is easily acquired, but needs careful attention to detail.

Do not change the factory settings until you have carefully evaluated the test above, and determined that the mechanism needs adjustment. Be sure that the proper tools are available before attempting adjustment or replacement of parts.

The four steel cables between the dancer arm and

the spring mounting bracket (top of deck) furnish the spring tension for the dancer arm. The tension may be adjusted by loosening the two screws which hold the bracket and moving (or twisting) the bracket.

Unthread the tape so that it does not interfere with the movement of the arm. Test the tension at the normal center position as shown in the figure.

Pull the dancer arm to the center point of its arc. Be sure that you pull the spring scale at a right angle to the arm. Before reading the tension, tap gently (with a small object such as a pencil) on the spring scale so as to overcome its friction.

The tension should read 3 ounces on a 1/4 inch machine (85 grams), 4 ounces on a 1/2 inch machine (113 grams), and 5 ounces on a 1 inch machine (143 grams).

If Adjustments Are Necessary

CAUTION

This airpot damping cylinder is a delicate glass tube. Make all adjustments with great care. Never use excessive force.

Remove all damping by loosening the nut on the rear of the air cylinder. Use a 1/4 inch nut driver, not a screwdriver for this adjustment.

Feel the action of the air cylinder by repeatedly pushing the dancer arm from its rest position (right end stop) to the left end stop.

Slowly tighten the adjustment nut, no more than

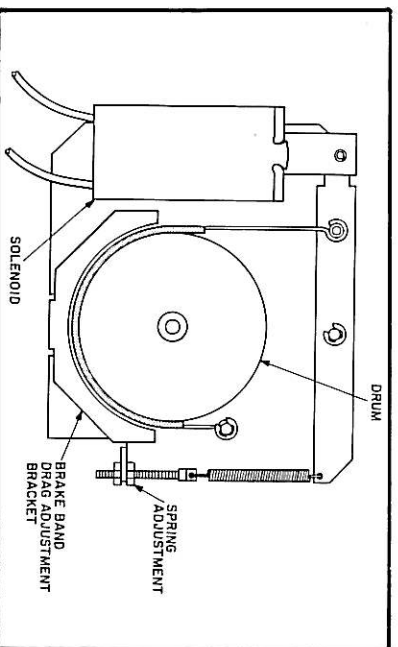

Figure 7-5 Brake Adjustments

1/4 turn at a time. As soon as you can feel the damping action of the air cylinder, turn the adjustment nut not more than 1/8 turn into the active adjustment range.

Replace the tape into its normal threaded configuration, and check the damping as in test 2 above.

Make very small adjustments and retest until you have achieved critical damping as described above.

7.5.2 Electronic Dancer Arm

Test

With tape loaded on the transport, place the transport into play mode. The dancer arm should not oscillate. Push the dancer to the right and to the left. Resistance to this motion should be felt in both directions.

If the dancer arm oscillates in play mode or offers no resistance to movement, suspect a problem in the flutter damper circuitry. If it is not a component problem, check the clearance between the magnet and the coil on the flutter damper circuit board. The gap should be .015 to .020 inches. The magnet should not extend over either end of the coil when the dancer arm is moved from one motion limit stop to the other.

If Adjustments Are Necessary

To adjust the clearance or the centering of the magnet arm, loosen the hex socket screw on the magnet arm clamp. Rotate the magnet arm so that the magnet is centered over the coil when the dancer arm is centered between its motion limit stops. Insert a .020 inch feeler gauge between the magnet and the coil to set the gap.

7.6 Reel Motor Brakes

Test

NOTE:

The following tests and adjustments apply to

the fail-safe mechanical brakes only. This system brakes the reels when the power is off or when the tape breaks.

Dynamic braking is furnished by the servo system which drives the reel motors.

1. Test the braking tension of both turntables in both directions.

Power is not needed for this test. Remove reels from the turntables. Move the turntables by hand.

The supply turntable should brake hard in the counter-clockwise direction and only half as hard in the clockwise direction.

The takeup turntable should brake hard in the clockwise direction and only half as hard in the counter-clockwise direction.

Spooling out direction brakes hard. Spooling in direction brakes only half as hard.

2. Test the brake release. Unplug both reel motors. Apply power to the machine. Insert an opaque card into the tape sensor slot. Brake solenoids should be on. Move the turntables by hand.

Both turntables should turn freely — with no drag in either direction.

If Adjustments Are Necessary

1. If brake tension must be adjusted, remove power from the machine. Load an empty 10½" diameter NAB reel on the supply turntable. Wrap a cord several times around the reel hub in a clockwise direction. Be sure that the cord overlaps so as to lock the cord to the reel.

Attach a spring scale to the free end of the cord. Pull slowly outward with the spring scale. Do not allow the cord to rub against the reel flanges.

Read the maximum tension achieved before the reel turns. This reading should be 4 ounces \pm ½ ounce (113 gm \pm 14 gm). This is the reeling in direction.

Remove the cord and wind in a counter-clockwise direction. Read the maximum tension achieved before the reel turns. This reading should be 8 ounces \pm ½ ounce (227 gm \pm 14 gm).

If the tension does not meet these specifications, loosen the spring adjustment nuts and tighten or loosen the spring.

Change the reel to the takeup turntable. Repeat the procedure described above. Note, however, that the reeling in direction and the reeling out direction for this turntable are opposite from the supply turntable.

Braking tensions for the takeup reel are: 4 \pm ½ ounce in a counter-clockwise direction and 8 \pm ½ ounce in a clockwise direction.

2. If the brake release must be adjusted, unplug both reel motors. Apply power to the machine. Remove the tape reel. Insert an opaque card into the tape sensor slot. The brake solenoids should be activated.

Both turntables must turn easily without brake drag. Inspect the brake assembly. Be sure that the solenoid is pulling ALL THE WAY into its seat. Too much spring tension will hold the solenoid out of its socket.

The brake band must not touch the drum when the solenoid is activated. The bracket which restricts the outward movement of the brake band is normally adjusted so that the movable end of the band is held closer to the hub than the fixed end of the band.

7.7 Tape Tension

Test

With tape loaded, put the transport into Play mode. The tensions of the supply reel and the takeup reel should balance so that the dancer arm rides close to the center point of its travel arc.

Test the tension of the tape with a finger on each side of the capstan. The tension should feel just about the same on each side.

Put the transport into FWD mode. Observe the ac-

celeration of the tape. Change into RWD mode. Observe the change from fast forward to fast reverse travel. If any jerkiness or loss of tension is observed at any time, then the adjustments on the Analog Torque Board will have to be checked.

NOTE:

When initiating a Fast mode, high tape tensions occur during acceleration. The dancer arm will be driven to the extreme left end of its travel arc. After proper speed is attained, the dancer arm can return to its relaxed position.

The factors affecting the exact position of the dancer arm are:

1. The reeling radius of the supply reel.
2. The direction of tape travel.

If Adjustments Are Necessary

1. DC Offset Null Adjustment (On Analog Torque Board)

A. Turn power on. Stop mode, with tape threaded and all reel motion arrested. (See Note below)

Connect the + lead of a dc voltmeter (1 volt full scale range) to TP 1. The -lead should be connected to TP 5 (ground).

Adjust R 12 for 0 volts. (This voltage can swing negative as well as positive.) It may be difficult to get an exact null. If this adjustment can be set within ± 0.1 volt, it will be satisfactory.

B. Repeat the above procedure for the takeup reel NULL adjustment by connecting the meter to TP 2, and adjust R 36.

NOTE:

If tape is in motion for the above adjustment, a null cannot be achieved. Motion can be stopped by removing tape from the photo cell. This should allow a rough adjustment, but proper alignment must be made with tape threaded through the photo cell. If motion still persists after this rough adjustment, it may be necessary to reduce the idle settings.

2. Idle Adjustment

A. Remove tape. Block the tape break sensor with an opaque card inserted into the slot. Turn power On, Stop mode.

Adjust R 18 for a slow idle of the supply reel motor. (About 20 RPM or 1 revolution every 3 seconds.)

B. Repeat the above adjustment for the takeup reel motor by adjusting R 111.

C. Reload tape, Stop mode. The slow idle should take up the slack tape after loading.

NOTE:

Idle speed should be set as high as practical as this will aid tape handling when entering Stop mode. The worse case may be observed with a full reel of tape vs an empty reel. Adjustments can be made during this test.

Reverse the position of the full reel and the empty reel. Be sure that the idle adjustments are not set high enough to produce tape creep.

3. Tension Adjustment

A. With tape loaded (half of the tape on each reel) run machine in play at 15 ips.

Using a tension gauge, adjust left tape tension (supply motor) of tape leaving reel to:

JH-110B ¼ inch tape	2½ oz.
JH-110B ½ inch tape	3½ oz.
JH-110B 1 inch tape	4½ oz.

B. Check and adjust dancer arm for center of motion with machine in play at 15 ips, and half of the tape on each reel.

C. With machine in play, disengage pinch roller from capstan and adjust take up tension such that play speed (15 ips) is simulated without benefit of pinch roller or capstan, such that dancer arm is re-centered.

At this time, with machine in play, you should be able to manually engage and disengage the pinch roller without any noticeable speed change. This means the capstan is doing no work, only metering the tape.

7.8 Capstan Speed

Test

1. Switch the REFERENCE switch into VAR mode, LO speed. With tape threaded, press the PLAY button.

Feel the tape motion by pressing the back of the tape with a finger.

Slowly vary the SPEED knob from lowest to highest setting. The tape speed should vary smoothly without sudden changes.

2. Change the SPEED switch into MED position. Repeat the above test.

3. Change the SPEED switch into HI position. Repeat the above test.

If these tests have shown smooth changes, with no sudden shifts or jerks, you may assume that the Phase Locked Loop circuit is maintaining its lock throughout the full range of speeds.

NOTE:

It is normal for the machine to switch to Stop mode whenever the SPEED switch is changed.

If Adjustments Are Necessary

(See Section 3 for a complete schematic and board layout for the Capstan Tach Board. The capstan tach is mounted on the bottom end of the capstan motor, inside the metal bell.)

1. Check the capstan tachometer by connecting an oscilloscope to TP 1 on the Capstan Tach Board.

Set the REFERENCE switch to VAR, the SPEED switch to HI. Initiate Play mode. Turn the speed knob fully clockwise. Peak-to-peak voltage should be 800 mv. with little amplitude jitter.

Adjust the cam located on the tach board for minimum amplitude jitter at TP 1.

See Section 3 for a complete schematic and board layout for the Phase Locked Loop Board.

2. Put the transport into STOP mode. No voltage should be present at TP 1 on the Phase Locked Loop Board.

Spin the capstan by hand. 4 to 5 volt pulses should be present at TP 1 while the capstan is turning.

3. To check the reference frequencies, attach a digital counter to TP 2 on the Phase Locked Loop Board.

Reference frequencies should read as follows:

	Standard Model
HI	19.2kHz (30 ips)
MED	9.6kHz (15 ips)
LO	4.8kHz (7½ ips)
	Low Speed Model, ½" capstan
HI	9.6kHz (15 ips)
MED	4.8kHz (7½ ips)
LO	2.4kHz (3¾ ips)
	Low Speed Model, ¼" capstan
HI	19.2kHz (15 ips)
MED	9.6kHz (7½ ips)
LO	4.8kHz (3¾ ips)

4. To adjust the VCO calibrator, set the machine to external reference, HI speed. Connect the digital counter to TP 2 on the Phase Locked Loop Board.

Adjust the VCO calibrator (R 18) to 19.2 kHz on the standard model or 9.6 kHz on the low speed ½ inch capstan model.

5. To set the phase locked loop circuit gain, load a roll of tape. Set the REFERENCE switch to VAR. Set the SPEED switch to HI. Turn the SPEED knob to full clockwise setting.

Attach a scope to TP 3 and select a vertical gain of 2.0 v/cm.

Adjust the LOOP GAIN control (R 42) for a duty cycle of +30%, -70%.

7.9 Manual Velocity Control Test And Adjustment

Test

Load a roll of tape. Put the transport into Stop mode. Set the MVC Joystick well over to the right end of its travel arc. While maintaining good contact to the transport with one hand, touch the Joystick with the other hand.

The LED at the tip of the Joystick should come ON. The transport should go into fast forward motion (MVC mode). Move the Joystick left and right until you find the point of no movement (near the center).

Set the Joystick to the left end of its travel arc, establishing a fast rewind motion. Release the Joystick.

The transport should stop.

If Adjustments Are Necessary

See Section 3 for a schematic and board layout of the Interface/Lamp Driver Board.

Adjust R3 on the Interface/Lamp Driver Board until the desired sensitivity is reached.

The centering adjustment is made by loosening the two set screws in the Joystick assembly. Hold the Joystick in the center position and turn the potentiometer with long-nosed pliers until a motion null is reached. Retighten the set screws.

Be sure that the Joystick does not short out to the deck plate at either end of its travel. Tabs on the potentiometer mounting bracket can be bent to restrict the travel of the Joystick.

7.10 Tape Load Photo Sensor Adjustment

The operation of the tape load sensor is dependent on the ambient lighting conditions and the particular type of leader tape used. Perform sensitivity adjustment with leader tape in the sensor, if used.

When power is applied to the transport, the deck

should be in stop mode with tape in the sensor. When tape is out of the sensor, the transport should be off. The adjustment potentiometer is located on a small PC board underneath the deck plate near the MVC control.

Turn the power on. Remove the tape from the tape load sensor.

Turn the sensitivity potentiometer counter clockwise until the STOP light comes on.

Turn the sensitivity potentiometer clockwise two turns.

7.11 Equalization And Biasing

The audio electronics in the JH-110B can be aligned to either NAB or IEC standards. Align the record and reproduce cards to the standard used most. Push buttons on these cards select the standard desired; LEDs on the front panel indicate which standard is selected. Use an elevated level alignment tape (250 nWb/m) to align the electronics. There are two considerations to keep in mind when using these alignment tapes.

High frequencies recorded on the alignment tapes are subject to self erasure losses. Expect the high frequency tones to diminish in amplitude with age. Store and handle these tapes carefully. Replace the tape or compensate for the loss if the high frequency tones diminish to insure a proper frequency response.

The majority of ¼ inch alignment tapes are full width recorded. At frequencies below 500 Hz the signal recorded in the guard bands is read by the head. This fringing effect, plus the phantom gaps due to the geometry and construction of the head, make the low frequency response seem bumpy rather than flat. These abnormalities in the low frequency range are, for the most part, caused by the full width recording. Once aligned as per Paragraph 7.12.12, the low frequency response will be flat under normal use with the proper guard band between the tracks.

There is an extremely complicated relationship between bandwidth, distortion, tape velocity and the amplitude of the bias signal recorded on the tape. Also, this relationship is different for each brand and type of recording tape manufactured. MCI has examined and tested various recording

tapes to find the optimum bias level which gives the greatest high frequency range with the lowest third harmonic distortion.

The amount of bias is determined by increasing the bias signal until the output level of a 10 KHz signal from the tape drops by a certain amount. This is referred to as over-biasing. After examining some of the most popular recording tapes, we have established the following levels of over-biasing.

Scotch 250 @ 15 ips, 7 1/2 ips	2dB overbias
Scotch 250 @ 30 ips	1dB overbias
Scotch 226 @ 15 ips, 7 1/2 ips	2 1/2dB overbias
Scotch 226 @ 30 ips	1dB overbias
Scotch 206 @ 15 ips, 7 1/2 ips	2dB overbias
Scotch 206 @ 30 ips	1/2dB overbias
Ampex 456 @ 15 ips, 7 1/2 ips	3dB overbias
Ampex 456 @ 30 ips	1 1/2dB overbias
Agfa 468 @ 15 ips, 7 1/2 ips	3dB overbias
Agfa 468 @ 30 ips	1dB overbias

7.12 Audio Electronics Alignment

MCI recording systems are aligned with MRL elevated level alignment tapes (0 VU = 250 nanowebers per meter).

NOTE:

Standard recording level has been set at a fluxivity level of 185 nanowebers per meter (nWb/m).

An elevated level of 250 nanowebers per meter is used throughout these tests and adjustments. This level (250 nWb/m) corresponds to the 0 VU level referred to in these instructions.

The distortion level is tested at recording levels of +3 VU which is a fluxivity level of 9 dB above the standard level or 370 nWb/m.

7.12.1 Channel VU Meter Calibration

Since the channel VU meters are used in several of the following adjustments, it is essential that their accuracy be confirmed before the following alignments are performed.

When no signal is applied to the channel, the meter needle should be aligned with the extreme left scale marker. If the needle is not directly over the mark, turn the mechanical adjustment screw

located directly under the meter to align the needle.

Connect a signal generator to the channel line input. Adjust the signal generator for a 1kHz output.

Connect an ac voltmeter to the channel line output.

If tape is not loaded, place a card in the tape sensor slot. Place transport in STOP, select Input mode.

Monitoring the ac voltmeter, adjust the output level of the signal generator to obtain a +4dBV reading (0VU).

Adjust the Meter Trim potentiometer (R31 on the Audio Mother Board) for a 0VU reading on the channel meter.

7.12.2 Reproduce Input Balance

Check for balanced capacitance at the differential inputs of the Repro Board Front End Amplifier.

Connect an oscilloscope to the Repro Board output.

With no tape loaded, place a card in the tape sensor slot. Select LO speed. Place in RECORD.

Observe the 120 KHz signal on the oscilloscope.

Turn C34 on the Audio Mother Board to obtain a minimum amplitude 120 KHz signal.

7.12.3 Head Wrap Adjustment

The Head Wrap adjustment is an eccentric mounting screw which controls the position of the head gap in relationship to the tape which is entering or leaving the head surface. The audio level peaks when the gap is located in the exact center of the angle so that the tape touches the head an equal distance on each side of the gap.

Set the GAL REP switch to GAL position. Press the REPRO button. Press the SAFE button.

Set the transport controls for a fixed reference.

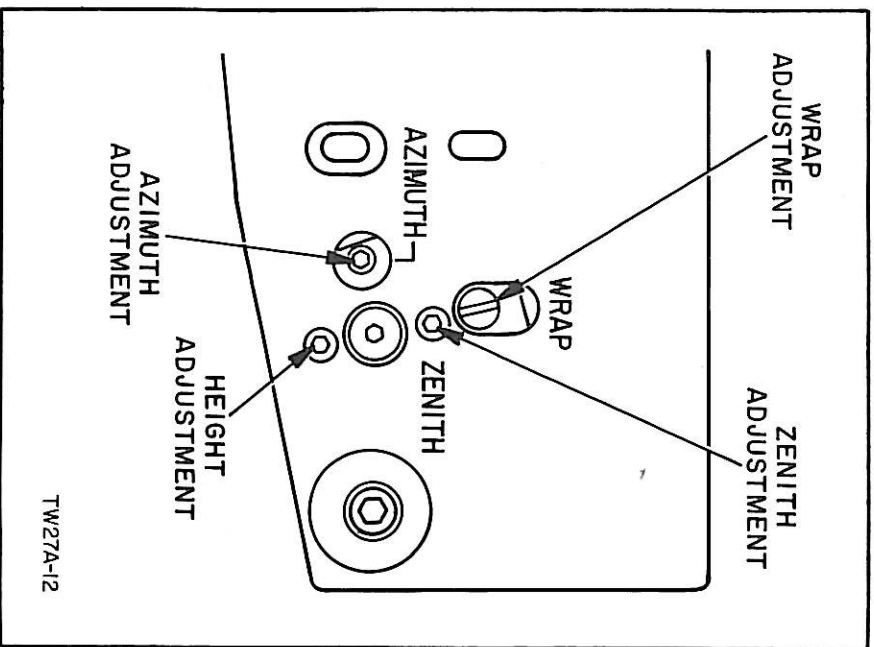

Figure 7-2
Head Adjustment

Choose 15 ips speed. Put into Play mode. Locate the 10 KHz tone on the alignment tape. On the head block, turn the repro head wrap adjustment screw for peak output on the channel meter.

Press the CUE button. On the head block, turn the record head WRAP adjustment screw for peak output on the channel meter.

7.12.4 Reproduce Level Adjustment

NOTE:

Instructions given below are for the use of elevated level tapes. If standard level tapes are being used, all instructions should read SET TO -3 VU instead of SET TO 0 VU.

Clean and demagnetize the heads. Load a 15 ips reproduce alignment tape.

Set the CAL REP switch to CAL position. Press the REPRO button. Press the SAFE button.

Set the transport controls for a fixed reference. Choose 15 ips SPEED. MED if standard machine, HI speed if low speed machine. Put into Play mode. Locate the 1 KHz level set tone on the alignment tape. On the Repro Card, adjust CAL REP for a reading of 0 VU on the channel meter.

Press the CUE button. On the Repro Card, adjust CUE LVL for a reading of 0 VU on the channel meter.

Adjust all channels as described above. The above adjustments set the gains of the reproduce circuits so that both the reproduce head and the record head (used as a reproduce head in cue mode) produce a standard level output.

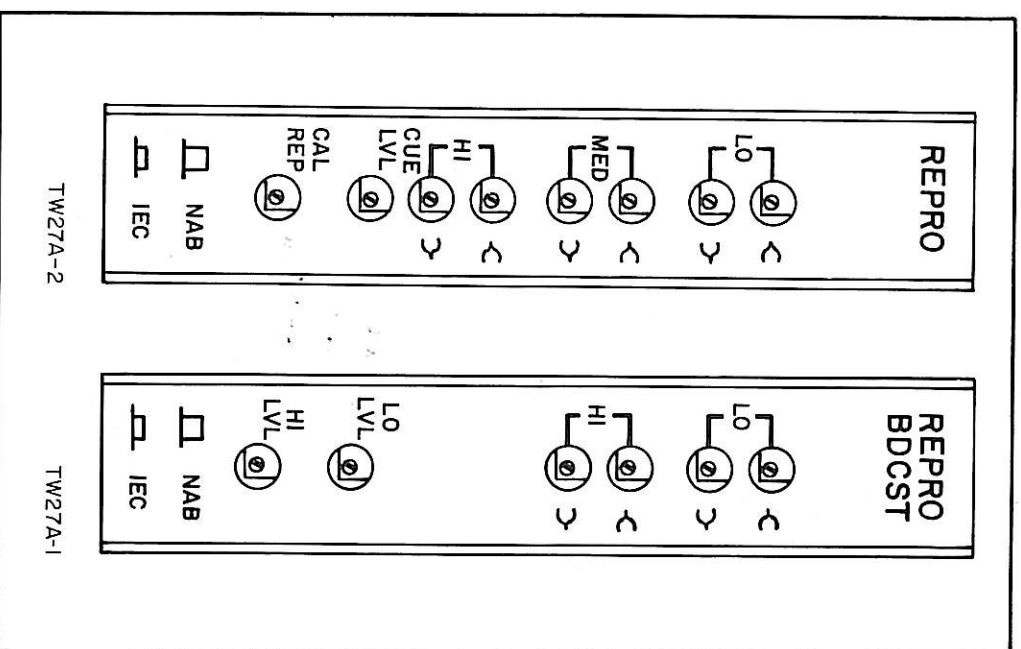

Figure 7-6
Repro Card Adjustments

7.12.5 Azimuth Adjustment

The Azimuth adjustment sets the relative phase of the tracks.

Two methods of adjustment are recommended.

Method 1

An MCI JH-22 Phase Meter is the ideal test instrument for this adjustment. This meter reads, directly in degrees, the relative phase of any two audio signals fed to its two inputs.

Connect the two outside tracks of the recorder to the two inputs of the phase meter.

Set the CAL REP switch to CAL position. Press the REPRO button. Press the SAFE button.

Set the transport controls for a fixed reference. Choose 15 ips speed. Put into Play mode. Locate the 10 KHz tone on the alignment tape. Adjust the AZIMUTH adjust screw for the reproduce head until you find the lowest relative phase reading on the phase meter.

Press the CUE button. Adjust the AZIMUTH adjust screw for the record head until you find the lowest relative phase reading on the phase meter.

Method 2

A simultaneous reading of a Lissajous figure on your oscilloscope and observation of the output meters of all tracks will give a satisfactory Azimuth adjustment.

Set the oscilloscope up with the output of the two outside tracks connected to the vertical input and the horizontal input respectively.

Adjust the gain of the horizontal channel and the vertical channel to be as identical as practical.

Set the CAL REP switch to CAL position. Press the REPRO button. Press the SAFE button.

Set the transport controls for a fixed reference. Choose 15 ips speed. Put into Play mode.

Using the 10 KHz tone from the alignment tape as a signal, observe the Lissajous figure on your scope screen. Ideally, the figure should be a

straight line tilted exactly 45° from the vertical.

At the same time watch the output meters for all channels. DO NOT turn the AZIMUTH screw far enough for the output to drop more than a small amount.

Press the CUE button. Turn the record head AZIMUTH adjustment screw until the tilt of the Lissajous figure is 45° from vertical. AT THE SAME TIME, watch the output meters for all channels. DO NOT turn the AZIMUTH screw far enough for the output to drop more than a small amount.

7.12.6 Reproduce Equalization Adjustments.

NOTE:

In all of the following instructions for adjusting equalization circuits, both record and reproduce, we have assumed a standard speed machine — 7½, 15, 30 ips. If your machine is a low speed machine — 3¾, 7½, 15 ips — please mark your manual so that the designated alignment tapes match the speed of your machine.

Load the proper HI speed alignment tape on the machine (30 ips for a standard machine, 15 ips for a low speed machine). Locate the 10 KHz tone on the alignment tape.

Set the CAL REP switch to CAL position. Press the REPRO button. Press the SAFE button.

Set the transport controls for a fixed reference, HI speed. Put into Play mode. On the Repro Card, adjust the HI speed, HI frequency potentiometer < for 0 VU reading on the channel output meter.

Adjust all channels the same way.

Change to the appropriate MED speed alignment tape.

Change to MED speed. All other controls remain the same. On the Repro Card, adjust the MED speed, HI frequency potentiometer < for 0 VU reading on the channel output meter. (Use -10 dB for low speed machine.)

Adjust all channels the same way.

Change to the appropriate LO speed alignment tape.

Change to LO speed. All other controls remain the same. On the Repro Card, adjust the LO speed, HI frequency potentiometer ← for -10 dB reading on the channel output meter.

Adjust all channels the same way.

The above adjustments flatten the high frequency response of the tape and the heads.

7.12.7 Erase Adjustments

NOTE:

A single 120 kHz oscillator supplies the power for all erase and bias functions in this recorder. It is located on the Strip Board for tracks 1 & 2. This board is attached to the inner side of the rear panel of the electronics assembly. If your machine has more than two tracks, the Strip Board used for the other tracks is similar with the oscillator section cut away.

Frequency check

NOTE:

The erase oscillator always operates when power is connected to the machine. This frequency check may be made with any setting on the controls.

Connect a frequency counter to C1 on the Audio Mother Board (point C on Figure 7-7).

Using a tuning wand adjust T1 on channel 1 & 2 Strip Board until the counter reads 120 kHz \pm 25 Hz in Record mode.

Set oscillator frequency for 120 kHz \pm 25 Hz while in record mode. Set to second peak, going in a clockwise direction.

Wave shape and amplitude check

Connect an oscilloscope to point C on the Audio Mother Board. (Refer to Figure 7-7)

Connect a volt meter to J10 pin 3.

Set oscillator gain pot (R9) on Strip Board for a meter reading of 1.75 volts rms.

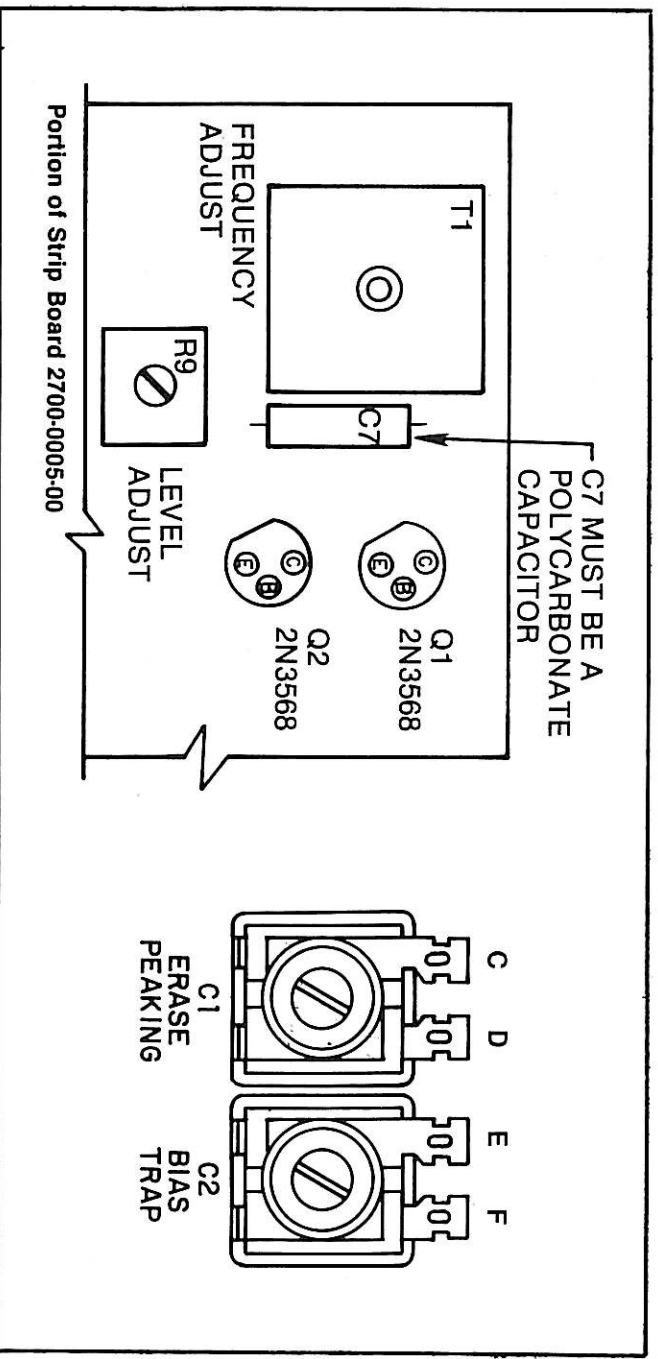

Figure 7-7 Erase and Bias Adjustments

NOTE:

Changing the 120 KHz oscillator gain disrupts the bias alignments. The bias adjustments, Sections 7.12.8 and 7.12.9 must be performed if R9 is turned.

Monitor erase voltage on erase peaking capacitor (C1) on Audio Mother Board at point C.

Turn C1 throughout its range.

Do this to all channels. There should be no distortion of the sine wave on the oscilloscope.

If there is any distortion, reduce the voltage by adjusting R9. Do not reduce the voltage at J10 pin 3 lower than 1.6 volts rms.

Adjust C1 for its peak voltage on all channels. This voltage should be 40 volts rms or greater.

**Depth Of Erasure Adjustment
(Erase head wrap and erase peaking adjustment)**

Load a roll of bulk erased tape. Set the transport controls for a fixed reference, 15 ips. Put in Record mode.

Method 1

Connect a Wave Analyzer to the channel under test. (Use HP 3581 or equivalent.)

Put the transport into Play mode. Zero the Wave Analyzer on the playback of the 1KHz tone. REWIND. Put the transport into Record mode — No signal input. The Wave Analyzer should read -80 dB on each channel.

Make the following adjustments while reading the output from the Wave Analyzer.

Turn the erase head WRAP adjustment screw until a minimum reading is found on the Wave Analyzer.

Trim C1 (erase peaking) for minimum reading on the Wave Analyzer.

Adjust all channels in the same way.

Method 2 If a Wave Analyzer is not available.

Record several minutes of 1 KHz tone at 0 VU level. Record on all channels. Remove the signal

input. REWIND. Put the transport into Record mode with no signal input. Turn your monitors up to their highest level.

Make the following adjustments while listening to the monitors.

Turn the erase head WRAP adjustment screw until you hear a null in the 1KHz tone coming from the monitors.

Trim C1 (erase peaking) for minimum 1KHz tone coming from the monitors.

Adjust all channels in the same way.

7.12.8 Bias Adjustments

Connect an ac voltmeter capable of reading at 120 KHz to the output of the Bias Card. Connect to point E on the Electronics Mother Board.

Load a roll of blank tape. Do NOT apply a signal.

Push the READY button.

Set the transport controls for a fixed reference, LO speed. Put into Record mode. Turn the LO potentiometer on the Bias Card fully clockwise. The voltage reading should be about 27 volts at point E.

Repeat the above procedure for each channel.

Reset the transport controls to MED speed. Put into Record mode. Turn the MED potentiometer on the Bias Card fully clockwise. The voltage reading should be about 27 volts at point E.

Repeat the above procedure for each channel.

Reset the transport controls for HI speed. Put into Record mode. Turn the HI potentiometer on the Bias Card fully clockwise. The voltage reading should be about 27 volts at point E.

Repeat the above procedure for each channel.

Bias trap adjustment

Connect an ac voltmeter to the Bias Trap. Connect at point F on the Electronics Mother board (see Figure 7-7).

Load a roll of blank tape. Do NOT apply a signal.

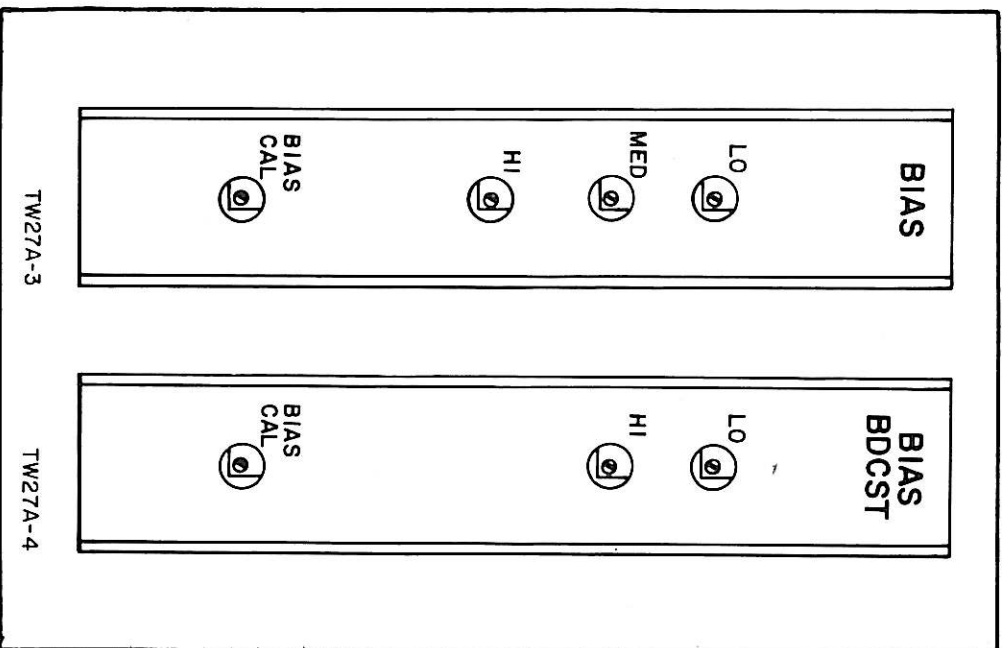

Figure 7-8
Bias Card Adjustment

Push the READY button.

Set the transport controls for a fixed reference, MED speed, Record mode. Adjust C2 for minimum reading. The reading at point F should be less than 75 mv.

Adjust all channels in the same way.

7.12.9 Over-Bias Level

MCI recommends overbiasing at 10 KHz due to increased resolution of the signal at the tape machine output.

Load a roll of blank tape. Apply a signal of +4 dB (0 VU).

Switch the REP CAL switch to CAL. Press REPRO button. Press READY button.

Set the transport controls for a fixed reference, LO speed, Record mode. Adjust Bias potentiometer for peak, then overbias to meet frequency response and distortion specifications.

Read the VU meter of the channel being adjusted. With the transport running in appropriate speed, adjust the LO potentiometer on the Bias Card. First turn the potentiometer counter-clockwise to back off the reading well below peak value. Then turn the potentiometer clockwise to a peak reading. Continue turning clockwise until the reading drops by the amount given in Section 7.11 for the type of recording tape in use.

Adjust all channels in the same way.

Reset the transport controls to MED speed, Record mode. Overbias according to the recommendations in Section 7.11.

Reset the transport controls for HI speed, Record mode. Follow the adjustment instructions above.

After optimizing bias for all three speeds, switch the transport to the speed you use most (use MED speed if you have no preference).

Press the channel BIAS button

On the Bias Card, adjust BIAS CAL for a 0 VU reading on the channel meter. Release the BIAS button.

7.12.10 Record Adjustments

Calibrate Record and Input Calibrate Adjustments.

Apply a 1 KHz signal at +4 dBm. Load a roll of blank tape.

Switch REC CAL to CAL position. Press REPRO button. Press READY button.

Set the transport controls for a fixed reference. Set speed to 15 ips (MED speed for standard machine, HI speed for slow speed machine). Press the PLAY and RECORD buttons.

On the Record Card, adjust CAL REC poten-

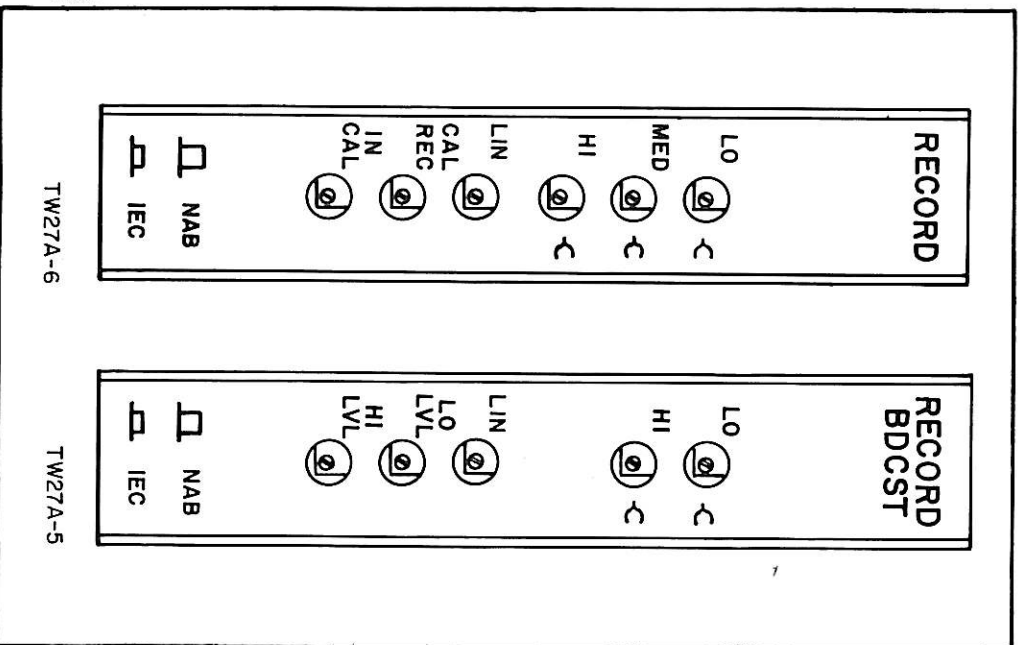

Figure 7-9
Record Card Adjustment

tiometer (recording adjustment) until the channel output meter reads 0 VU.

Press INPUT button. On the Record Card, adjust IN CAL potentiometer (monitoring adjustment) until the channel output meter reads 0 VU.

NOTE:

Both the CAL REC and the IN CAL potentiometers are shown on the Record Board schematic in Section 5.

The IN CAL adjustment sets the gain of the monitoring channel when it is in INPUT mode. This allows the operator to adjust incoming signal levels before starting to record.

7.12.11 Record Equalization Adjustment

Apply a 10 kHz signal. Use 0 VU for 15 and 30 ips, -10 VU for all slower speeds. Load a roll of blank tape.

Switch the CAL REC switch to CAL position. Press the REPRO button. Press the READY button.

Set the transport controls for a fixed reference, LO speed, Record mode. On the Record Card adjust the LO < trimmer.

Reset the transport controls to MED speed, Record mode. On the Record Card adjust the MED < trimmer.

Reset the transport controls for HI speed, Record mode. On the Record Card, adjust the HI < trimmer.

Adjust all channels in the same way.

7.12.12 Reproduce Low Frequency EQ Adjustment

Connect a variable frequency audio generator to the input. Load a roll of blank tape.

Switch the REPRO CAL switch to CAL position. Press the REPRO button. Press the READY button.

Set the transport controls for a fixed reference, LO speed, Record mode. Watch the channel output meter as you slowly sweep the audio signal from 30 Hz to 100 Hz. Observe the low frequency bumps.

On the Repro Card, adjust the LO speed LO frequency potentiometer > while sweeping the audio signal through the above range.

Center the bumps about the zero line so that the response over the entire range achieves maximum flatness.

Reset the transport controls to MED speed, Record mode. On the Repro Card, adjust the MED speed LO frequency potentiometer > while sweeping the audio signal through the range from 30 Hz to 100 Hz.

7.12.13 Record Linearity Adjustment

NOTE:

This adjustment is not available on all models. If your transport does not have a LIN adjustment, simply skip this procedure.

The intermodulation distortion of tapes varies widely with type of tape and with manufacturing processes. The record linearity adjustment on each Record Card can compensate for a wide variation in characteristics provided the procedure outlined below is followed very closely.

NOTE:

Complete all mechanical adjustments and set all bias, record, reproduce levels before starting this procedure.

The relationship between intermodulation distortion and record level is shown below. This is a generalized chart with no attempt to make it conform to a particular type of tape.

Curve "A" in Figure 7-10 shows the distortion vs record level for a typical tape.

Curve "B" is the distortion vs record level which can be achieved with correct adjustment of the linearity control.

Curve "C" is the distortion vs record level which may result if improper adjustment procedure is followed.

Set the CAL REPRO switch to CAL position. Set the CAL REC switch to UP position. Press the

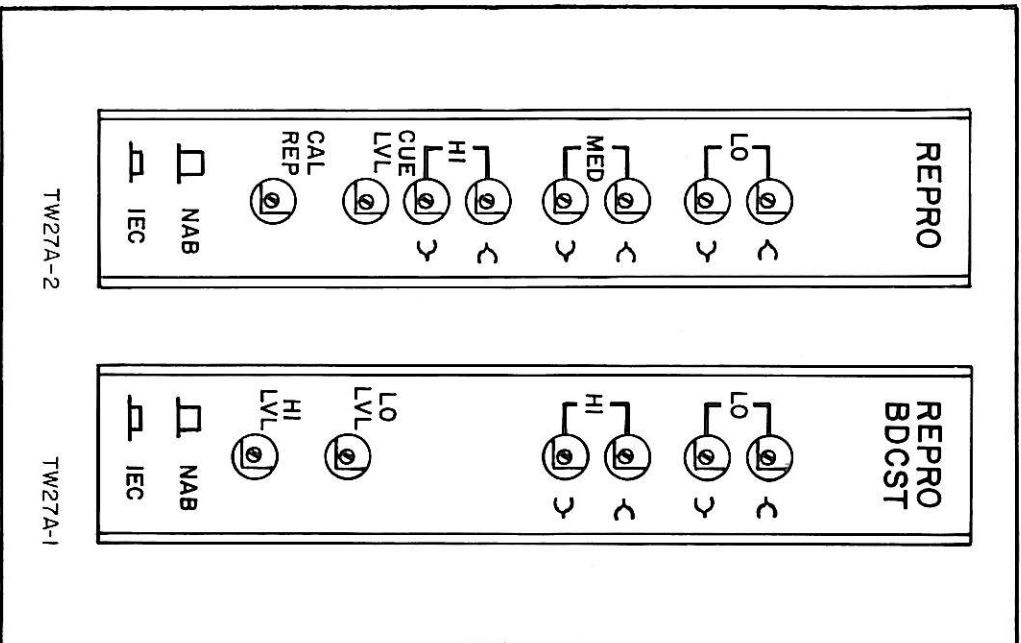

Figure 7-6
Repro Card Adjustment

Center the bumps about the zero line so that the response over the entire range achieves maximum flatness.

Reset the transport controls to HI speed, Record mode.

On the Repro Card, adjust the HI speed LO frequency potentiometer → while sweeping the audio signal through the range from 30 Hz to 100 Hz.

Center the bumps about the zero line so that the response over the entire range achieves maximum flatness.

Adjust all channels in the same way.

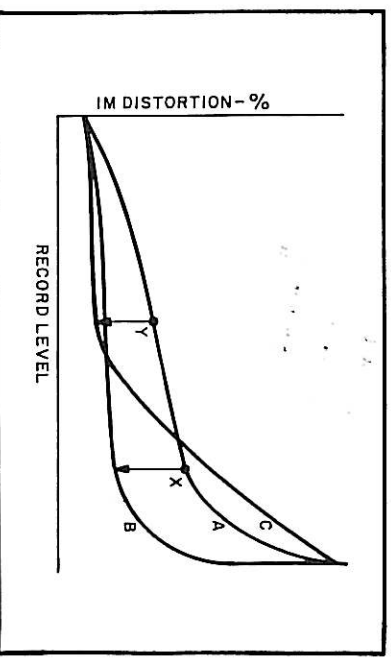

Figure 7-10
Intermodulation Distortion Curves

REPRO button. Press the READY button.

Set the transport controls for a fixed reference. Choose the most used speed (if no preference, use 15 ips). Put into Record mode.

Connect the IM analyzer to the input and the output of the track to be tested. Turn the front panel REC LEVEL potentiometer to 1/4 scale.

On the Record Card, turn the LIN potentiometer to minimum (counter-clockwise).

Slowly increase the REC. LEVEL (turn the front panel control) until the IM analyzer shows a distortion reading of about 3%, shown as point X in Figure 7-10.

Adjust the LIN potentiometer on the Record Card until a minimum distortion reading is obtained. This reading is generally below 1 1/2%.

A distortion vs record level curve similar to curve "B" in Figure 7-10 should result.

Adjust all channels in this way.

NOTE:

The audio level must be high enough to produce 3% IM distortion before the record linearity control is adjusted. If this adjustment is made at a lower audio level (such as point "Y" in Figure 7-10) a record level vs distortion response similar to curve "C" in Figure 7-10 may result.

This linearity adjustment should be made whenever a new type of tape is to be used.

Optimum adjustment varies widely with tape characteristics.

7.12.14 Noise Tests

Connect an ac voltmeter to the channel output with the following weighting network between the output and the meter.

The network in Figure 7-11 will result in an attenuation of 3.0 dB at 30 Hz and at 18 KHz.

Load a roll of blank tape. Head shield **MUST** be in UP position. Put into STOP mode. The noise reading should be -66 dBm or lower.

Reset the transport controls for a fixed reference, 15 ips speed. Put into PLAY mode. The noise reading should be -64 dBm or lower.

Put the transport into Record mode with no signal input. After recording several minutes of Bias only, Rewind the tape. Put the transport into PLAY mode. The noise reading should be -60 dBm or lower.

Test all channels in the same way.

7.13 Quick Alignment Check

The following alignment check should be performed prior to each recording session, whenever the brand of tape is changed, or when the equalization standard is switched. This is not intended to replace the maintenance alignments (Sections 7.2 through 7.12), which must be performed periodically. Use this section to verify the performance on a daily basis.

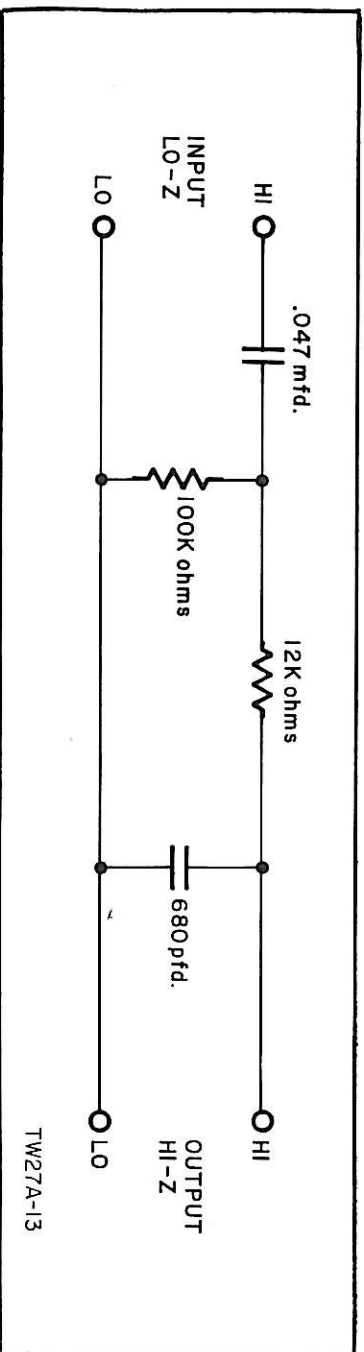

Figure 7-11
Weighting Network

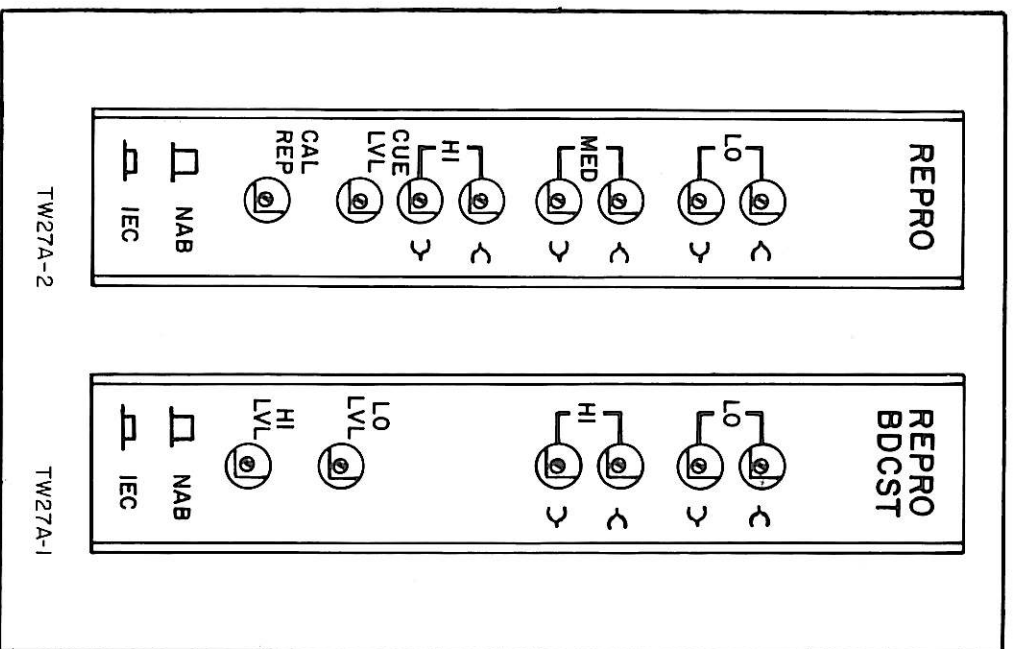

Figure 7-6
Repro Card Adjustment

The following is a list of the minimum equipment necessary to perform an alignment check:

- Head Demagnetizer
- Cotton Tipped Swabs
- Isopropyl Alcohol or equivalent head cleaner
- MRL Reproduce Alignment Tape (Elevated level, 250 nWb/m)
- Bulk Erased Tape
- Audio Signal Generator Krohn-Hite Model 5800
- Oscilloscope Phillips Model 3232 (2 mv/cm vertical sensitivity, 10 MHz Bandwidth, 0.2 msec/cm Horizontal sweep)

1. **Clean and demagnetize the heads.**
2. **Check the head wrap alignment of the Repro and Record heads.**

Select the tape speed which will be used during recording.

Load the reproduce alignment tape corresponding to the selected tape speed.

Place CAL REPRO switch in the CAL position.

Press REPRO and SAFE buttons.

Play the 10kHz tone on the alignment tape.

Press thumb against supply reel to apply a drag force to the motor. VU meter should dip slightly.

If the VU meter level increases under load, the head wrap requires adjustment. Turn the Repro head wrap adjustment screw to peak the reading on the VU meter.

Press CUE button. Check the record head wrap as above, and adjust as necessary.

3. **Check the azimuth alignment of the Repro and Record heads.**

Connect the outputs of the two outside tracks to the vertical and horizontal inputs of the oscilloscope. Set the vertical gain equal to the horizontal gain for observing a Lissajous pattern.

Press the REPRO button.

Play the 10kHz tone on the alignment tape. The oscilloscope Lissajous pattern should be tilted to 45°.

If necessary, slowly turn the reproduce head azimuth adjustment to tilt the Lissajous pattern to 45°.

Press CUE button. Check the record head azimuth as above and adjust if necessary.

4. **Check the calibrated repro level for 0 VU on the channel meter for each channel.**

Press REPRO and SAFE buttons.

Play the 1 kHz level set tone on the alignment tape. Channel VU meter should read 0 VU.

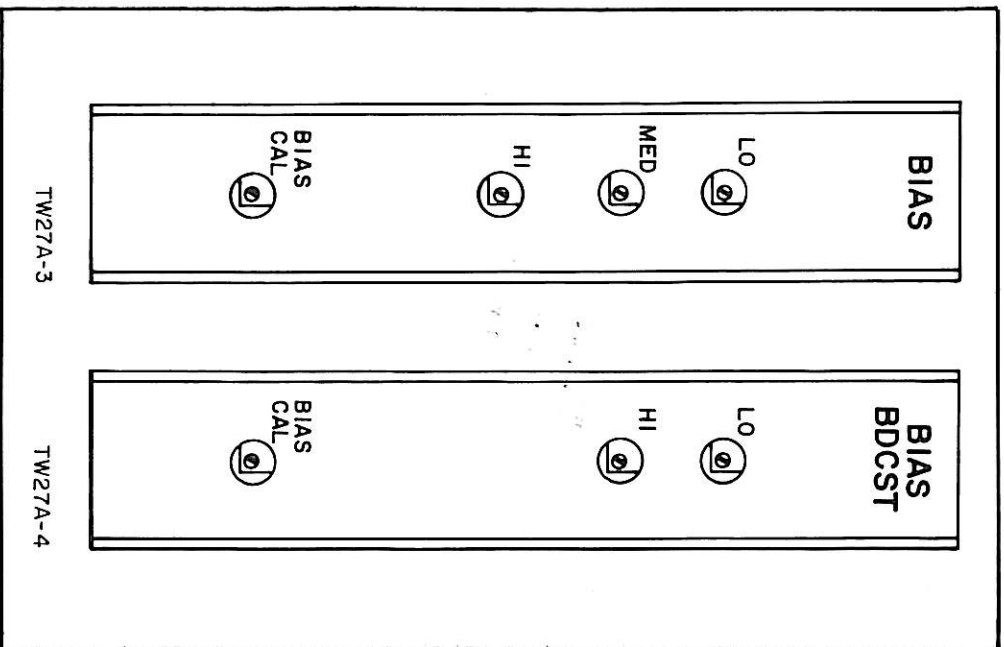

Figure 7-8
Bias Card Adjustment

If necessary, adjust the CAL REP potentiometer on the Repro Card for a 0 VU meter reading.

(On the broadcast deck, adjust the LO LVL or HI LVL potentiometer, depending on the selected tape speed.)

5. Check the cue level for 0 VU on the channel meter for each channel.

Press the CUE button.

Play the 1 kHz level set tone on the alignment tape. Channel VU meter should read 0 VU.

If necessary, adjust the CUE LVL potentiometer on the Repro Card for a 0 VU meter reading.

6. Check the Repro Card high frequency equalization for a 0 VU level on the channel meter for each channel.

Press the REPRO button.

Play the 10 kHz tone on the alignment tape. Channel VU meter should read 0 VU.

If necessary, adjust the LO ◀, MED ◀, or HI ◀ potentiometer, depending on the selected speed, for a 0 VU meter reading.

7. Check the Bias level for a 0 VU reading on the channel meter for each channel.

Rewind the alignment tape and load a reel of bulk erased tape. Use the same type of tape which will be used for recording.

Connect the signal generator to the channel line input. Adjust output for 10 kHz at +4 dBm.

Place the REPRO CAL and REC CAL switches in the CAL positions.

Press the BIAS button.

Press the READY button.

Record the 10 kHz tone on the tape at the speed which will be used for recording. Channel VU meter should read 0 VU.

If the VU meter does not read 0 VU, perform the following adjustment.

Release the BIAS button.

Press the REPRO button.

Turn the LO, MED, or HI Bias potentiometer, depending on the tape speed selected, several turns counter-clockwise.

Turn the LO, MED, or HI Bias potentiometer clockwise until the VU meter peaks.

Adjust the LO, MED, or HI Bias potentiometer clockwise to lower the VU meter reading from its peak reading by the amount indicated in Section 7.11.

Press the BIAS button.

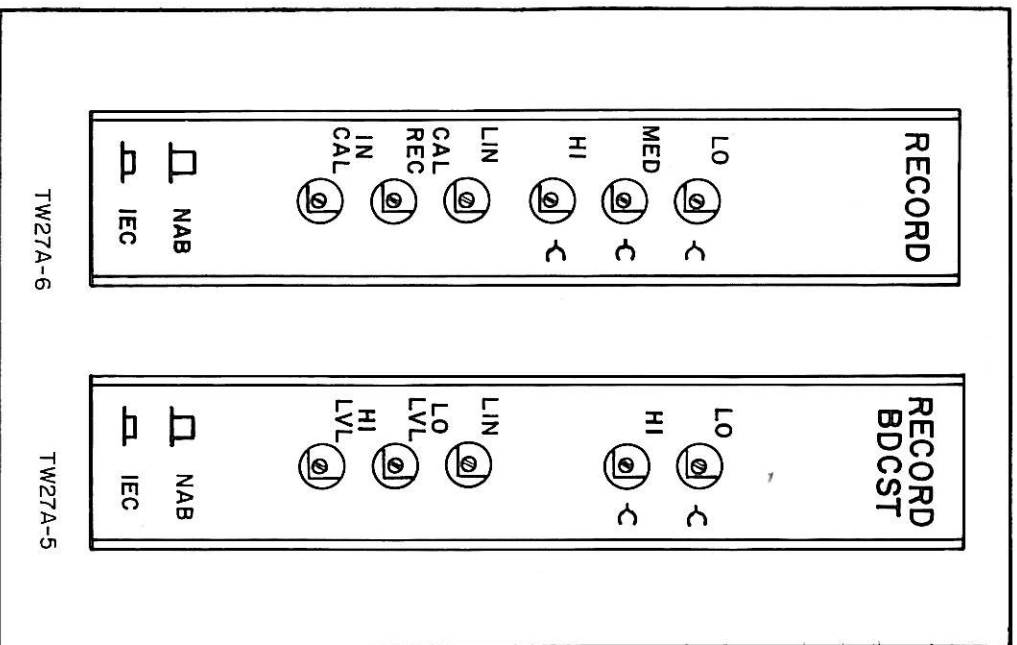

Figure 7-9 Record Card Adjustment

Adjust the BIAS CAL potentiometer on the Bias Card for a 0 VU reading on the channel meter.

Release the BIAS button.

8. **Check the calibrated record level for a 0 VU reading on the channel meter of each channel.**

Adjust the signal generator output for 1 KHz at +4dBm.

Press the REPRO button.

Record the 1 KHz tone on the tape. Channel VU meter should read 0 VU.

If necessary, adjust the CAL REC poten-

tiometer on the Record Card for a 0 VU meter reading.

(On the broadcast deck, adjust the LO LVL or HI LVL potentiometer, depending on the selected tape speed.)

9. **Check the input calibration level for a 0 VU reading on the channel meter of each channel.**

Press the INPUT button.

Record the 1 KHz tone on the tape. Channel VU meter should read 0 VU.

If necessary, adjust the IN CAL potentiometer on the Record Card for 0 VU meter reading.

10. **Check the Record Card high frequency equalization for a 0 VU level on the channel meter of each channel.**

Reset the signal generator for a 10 kHz signal at +4 dBm.

Press the REPRO button.

Record the 10 KHz tone on the tape. Channel VU meter should read 0 VU.

If necessary, adjust the Record Card's LO ◀, MED ▶, or HI ◀ potentiometer, depending on the selected tape speed, for a 0 VU reading on the channel meter.

11. **Check the Repro Card low frequency equalization level for a minimum deviation from 0 VU on each channel meter over the low frequency range.**

Record the signal generator output on the tape.

Slowly vary the signal generator frequency between 30 Hz and 100 Hz. Channel meter movement should be centered around 0 VU.

If the meter swing is not centered around 0 VU, adjust the LO ▶, MED ▶, or HI ▶ potentiometer, depending on the selected tape speed, to center the movement while sweeping the frequency between 30 and 100 Hz.

7.14 Scrape Flutter Filter

Test

The scrape flutter filter on the JH-110 transports requires cleaning and lubricating once every year or every 2000 hours of operation, which ever comes first. Cleaning is also recommended whenever visual inspection reveals oxide, dirt, hairs, etc. on the roller shafts.

If Cleaning Is Necessary

Removal:

- Step 1. Remove the head bridge assembly from the transport.
- Step 2. Remove the Scrape Flutter Filter Assembly from the head bridge assembly. See figure 7-12.

NOTE:

An ultrasonic cleaner and high speed light grease are required for this procedure. If you do not have an ultrasonic cleaner, the cleaning and lubricating may be handled by a local jeweler or watchmaker.

Remove the 8-32 socket head screw securing the scrape filter to the head bridge. Save the screw and the spacer assembly (1/2" tape only), they will be required for reassembly.

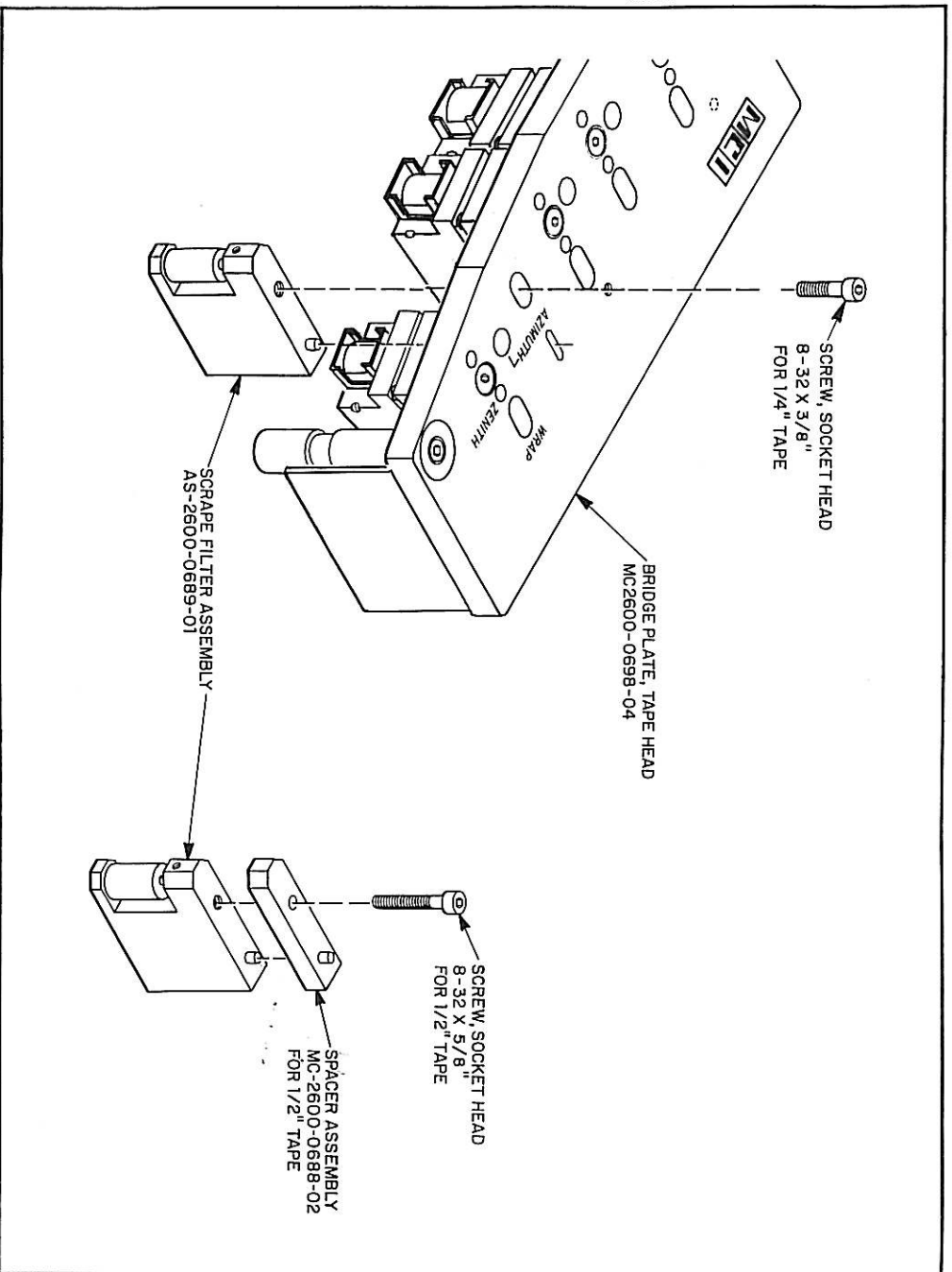

Figure 7-12 Scrape Filter Removal

Disassembly and Cleaning

Step 1. Scribe a mark on the brass jewel holder parallel with the center line of the set screw as shown in figure 7-13 to indicate the correct orientation of the holder. Some scrape flutter filters may already have this scribe mark.

Step 2. Remove the roller and shaft assembly. See figure 7-13.

- a. Loosen the 2-56 set screw that holds the brass jewel holder.
- b. Push the roller up to lift the brass jewel holder and remove the roller from the

housing. Do not tip the roller while pushing the jewel holder up or you may damage the pivot pins.

- c. Pull the brass jewel holder out of the housing.

Step 3. Place the roller, brass jewel holder, and the housing assembly into an ultrasonic cleaner for cleaning.

NOTE:

If any traces of oxide remain after cleaning, polish with jeweler's rouge to remove remaining deposits. After polishing, ultrasonically clean the pieces again.

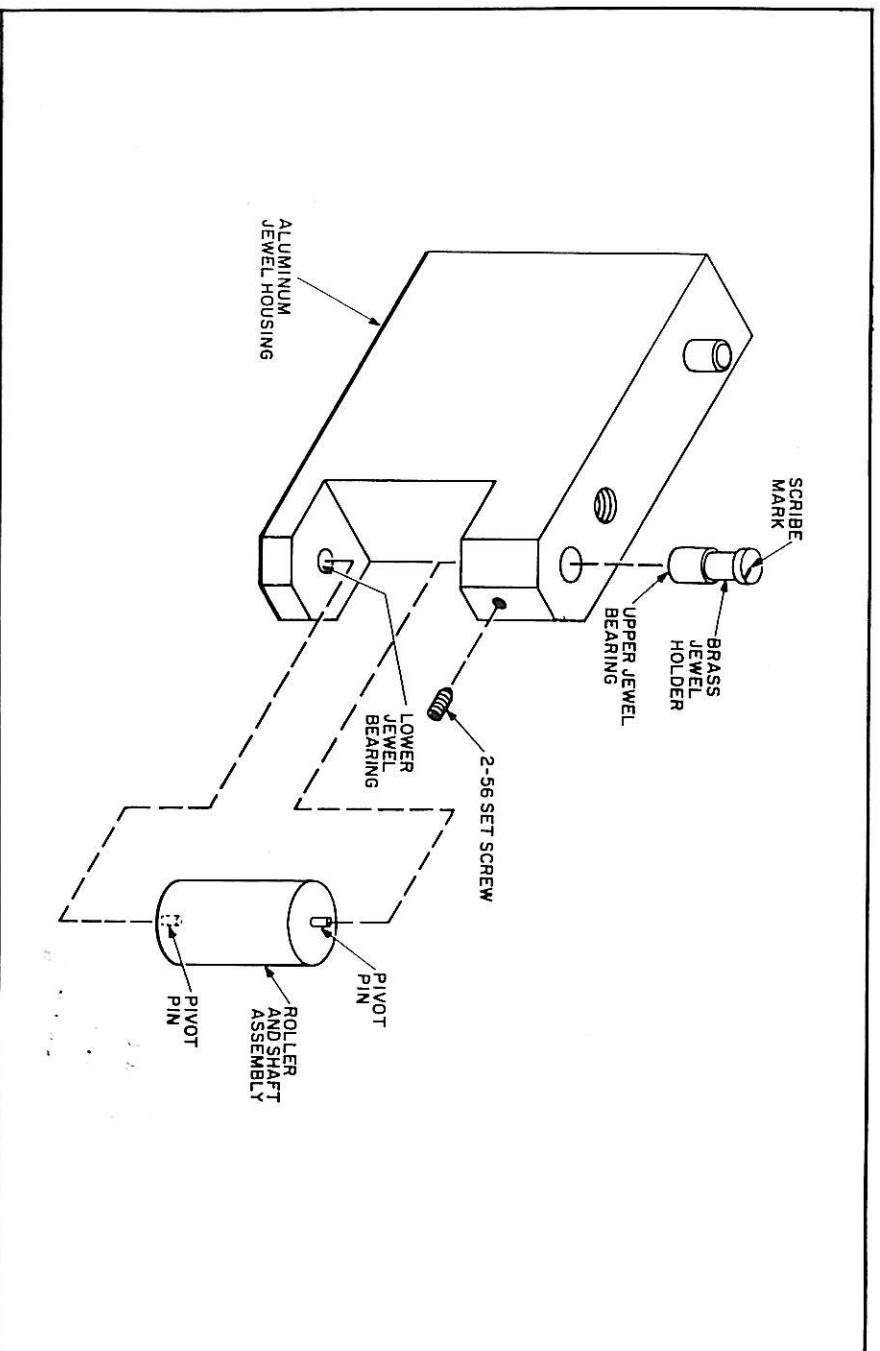

Figure 7-13 Scrape Filter Disassembly

Step 4. Very lightly lubricate the TIP of each roller PIVOT PIN with high speed light grease. We recommend Beacon 325 precision bearing lubricant.

Reassembly

Step 1. Align the scribe mark on the brass jewel holder with the center line of the set screw and slide the brass jewel holder into the housing. Do not seat it all the way down into the housing at this time.

Step 2. Carefully insert the roller pivot pin into the lower jewel bearing.

CAUTION

Insert the pivot pin into the center of the jewel bearings. Any side movement or tilt may damage the jewel or break the pivot pin.

Step 3. Center the roller and slide the brass jewel holder down onto the top pivot pin.

Step 4. Position the brass jewel holder to allow a 0.0005 to 0.001 inch vertical play of the roller. Be sure that the scribe mark is aligned with the set screw.

Step 5. Lightly tighten the set screw to secure the brass jewel holder. Recheck the vertical movement. Loosen the set screw and re-adjust the clearance if necessary. Check to see that the roller spins freely.

CAUTION

Overtightening the set screw may distort the jewel holder, crack the jewel, or bind the pivot pin.

Replacement And Alignment

Step 1. Replace the spacer on the filter assembly if used (1/2" tape). Reposition the scrape filter assembly under the head bridge and thread in the screw.

Step 2. Replace the head bridge assembly on the transport.

Step 3. Adjust the position of the scrape filter assembly. There are two methods for aligning the position of the scrape filter. The first method given is the preferred one. It, however, requires a wide-band flutter meter. Standard flutter meters use a frequency too low to determine the operation of the scrape flutter filter. If you cannot obtain a wideband flutter meter, use method two.

Method 1

- Connect the wideband flutter meter to the transport as recommended by the manufacturer. Select a bandwidth of at least 5KHz.
- Load a roll of erased tape.
- Place the transport into record mode and adjust the position of the scrape flutter filter to obtain a minimum reading on the meter.
- Tighten the socket head screw. If the flutter increases after tightening the screw, readjust the position.

Method 2

- Connect an audio oscillator to the line input, select 10KHz. Monitor the line output.
- Place the transport in record and monitor the repro.
- Carefully listen to the 10KHz repro. You should hear some distortion noise mixed with the 10KHz tone.
- Adjust the position of the scrape flutter filter until the roller barely makes contact with the tape, causing the roller to turn.
- Fine tune the position of the scrape filter by nulling the distortion noise in the 10KHz tone. Tighten the socket head screw.

SECTION 8

TROUBLESHOOTING

8.1 Introduction

Do not attempt to troubleshoot or repair this tape recorder unless you have a thorough understanding of the operation and circuitry. To familiarize yourself with the tape deck's operation, read the manual and use the block diagrams to follow the flow through the schematics. This section of the manual contains a collection of practical information which will aid you in your troubleshooting efforts.

8.2 Control Logic Board

To aid in the job of isolating trouble on this board, MCI has made available an optional troubleshooting aid — a Logic Annunciator Board.

NOTE:

In use, the Logic Annunciator Board plugs directly into the Control Logic Board. It may be left in this position during operation if desired.

In this section of the manual the following troubleshooting aids are provided:

1. A Truth Table of the Annunciator Board for each control condition.
2. A key to the abbreviations used on the Annunciator Board and the Truth Table.
3. A correlation between each IC and the functions it controls:

A. A list of the malfunctions which occur if each IC is open.

B. A Troubleshooting Chart using the Truth Table as a guide.

LOGIC ANNUNCIATOR BOARD (An optional troubleshooting aid 25B177)

The following list is a key to the abbreviations used on the Annunciator Board. These same abbreviations are used on the Truth Table. The Truth Table shows which of the LEDs on the Annunciator Board should be ON during each mode of operation.

The Logic Annunciator Board and its Truth Table may be used to isolate or localize any trouble which occurs on the Control Logic Board. The Annunciator Board is made to be plugged directly into the Control Logic Board. To use this tool, step through the list of control modes shown on the Truth Table. At each step, several LEDs will turn ON. Check the Truth Table to be sure that each light that should be ON is turned ON, and each light that should be OFF is turned OFF.

ANY circuit which corresponds to the Truth Table may be assumed to be working correctly, and any circuit which does NOT correspond to the Truth Table may be assumed to be malfunctioning.

JH-110 LOGIC ANNUNCIATOR DEFINITIONS

Al Enab	Autolocator enable command
DMVC	Deck Manual Velocity Control (MVC) touched last
RMVC	Remote Manual Velocity Control (MVC) touched last
MVC	Main Manual Velocity Control (MVC) command
F.Fet	Fast FET command
Lifter	Tape lifter out command
Rw Cmd	Rewind command
Rw Lt	Rewind lite command
FF Cmd	Fast forward command
FF Lt	Fast forward lite command
Bks	Brake release command
Stop	Stop command
R.Idle	Right (takeup) motor idle command
PP Lt	Play preset lite command
P Lt	Play left (supply) motor command
P Rt	Play right (takeup) motor command
Rec	Record command
Rec Mom	Record momentary command
Edit	Edit command
Sh	Shield down command ²
Sh Lt	Shield lite command ²

NOTES:

These notes apply to both the Definitions and the Truth Table.

1. Only one of the pair (DMVC or RMVC) will be ON at all times to indicate the last control touched. If the optional Remote Control has not been supplied with this machine, the DMVC light should always be ON.
2. The Shield Down command and the Shield Lite command do not apply to the JH-110 machine. These commands are functional ONLY for the JH-100 and the JH-114 transports. Either, or both of these lights may turn ON or OFF without affecting the operation of this machine.

JH-110 LOGIC ANNUNCIATOR TRUTH TABLE

CONTROL MODE	AL ENAB	DMVC	RMVC	MVC	F. FET	LIFTER	RW CMD	RW LT	FF CMD	FF LT	BKS	STOP	R. IDLE	PPLT	P LFT	P RT	REC	REC MOM	EDIT	SH	SHLT
REWIND	ON		ON	ON	ON	ON		ON									
FORWARD	ON			ON	ON		ON	ON	ON								
STOP	ON								ON	ON	ON						
PLAY	ON								ON			ON	ON	ON			
RECORD	ON								ON			ON	ON	ON			
RECORDMOMENTARY	ON								ON			ON	ON	ON	ON	ON	
EDIT									ON		ON		ON				
MVC TOUCHED		ON	ON						ON								
MVC LATCHED	ON	ON	ON	ON					ON								
AUTOLOCATOR	ON		ON	ON		ON			ON	ON							
NO TAPE	
MANUAL LIFTER OUT	
	A	B	C	D	E	F	G	H	I	J	K	L	M	N	O	P	Q	R	S	T	U

ICs AND THEIR FUNCTIONS

The interconnecting of the logic chips used in the Control Logic Board makes it impossible to ascribe a single function to an IC, or conversely to ascribe a single IC to a function.

The following list is a generalization obtained by removing each IC in turn from its socket and observing the effects on the control functions. This list is to be used as a guide ONLY.

NOTES ON FUNCTIONS WHICH DO NOT OPERATE CORRECTLY WHEN THE IC IS REMOVED FROM ITS SOCKET.

- | | | | |
|----|---|----|---|
| 1 | RMVC-DMVC'S | 14 | (Controls shield functions not used on this machine.) |
| 2 | REWIND function does not work. | 15 | MVC does not turn OFF. PLAY and |
| 3 | FWD function does not work. | | |
| 4 | PLAY-RECORD functions do not work. | | |
| 5 | Transport will obey all control buttons except STOP. | | |
| 6 | RECORD function does not work. | | |
| 7 | Transport goes into EDIT mode instead of STOP. | | |
| 8 | MVC functions do not work. | | |
| 9 | RWD mode cannot be turned OFF. | | |
| 10 | FWD mode cannot be turned OFF. | | |
| 11 | Transport goes into PLAY mode with BRAKES ON (reels STOP). | | |
| 12 | Transport goes into PLAY mode with NO TAKEUP TENSION (STOP button has been pushed). | | |
| 13 | (Controls shield functions not used on this machine.) | | |

- RECORD do not work.
- 16 TAPE LIFTER does not work. AUTOLOCATOR does not work. EDIT does not work.
- 17 EDIT does not work. TAPE LIFTER stays in OUT position.
- 18 MVC does not work. PLAY and RECORD do not work.
- 19 BRAKES remain ON. RWD and FWD lights both remain ON.
- 20 REEL TENSIONS are seriously wrong. STOP light will not come ON.
- 21 REEL TENSIONS are seriously wrong.

TROUBLESHOOTING PROCEDURE — (Using the logic annunciator and its truth table)

Put the transport into each Control mode named on the Truth Table. From one to eight LEDs will light. Check that each light called for by the chart is ON, and that NO lights are ON EXCEPT those shown on the chart.

If any ON light is OFF, check its coordinates on the chart. (See the bottom line and the column to the far right.) The coordinates of the lights are us-

ed as the key to the table on the next page. This table identifies the schematic numbers of the ICs which may be involved in any malfunction. As a general rule, the IC numbers given first on the list are more likely to be causing the trouble.

SPECIAL NOTE:

In preparation of these lists, we assumed that the outputs of the TTL chips were the potential source of trouble. Therefore we did not include the IC numbers whose inputs only have contact with the "information path." A shorted input of some logic chip not on the list may cause a malfunction. However, TTL chips rarely develop "input circuit" trouble after their initial burn-in period.

When a malfunction is suspected, the Annunciator Board should be used to check the entire Truth Table. Note which lights are wrong in each mode of operation. Spend a few minutes in cross-correlating the information gathered from the Truth Table and from the Troubleshooting Chart. By using this process to eliminate all but a very few of the ICs, you should be able to pinpoint the trouble very quickly.

LITE NO.	SCHEMATIC NO. OF ICs WHICH MAY CAUSE TROUBLE	LITE NO.	SCHEMATIC NO. OF ICs WHICH MAY CAUSE TROUBLE
A1	16, 8, 11, 4, 18, 12, 7, 6, 20, 17, 9, 2, 10, 3	K2	(Same as K1)
A2	(Same as A1)	K3	(Same as K1)
A3	(Same as A1)	K4	(Same as K1)
A4	(Same as A1)	K5	(Same as K1)
A5	(Same as A1)	K6	(Same as K1)
A6	(Same as A1)	K7	(Same as K1)
A9	(Same as A1)	K8	(Same as K1)
A10	(Same as A1)	K9	(Same as K1)
B1-B12	See NOTE 1 — Check IC 1	L3	5
C1-C12	See NOTE 1 — Check IC 1	M3	19, 20, 21, 18, 12, 17, 8, 15, 5, 7, 10, 3, 9, 2, 6, 16, 11, 4
D8	8, 16, 15, 5, 18, 12, 20, 7, 17, 11, 4, 10, 3, 9, 2	M7	(Same as M3)
D9	(Same as D8)	N4	11, 4, 5, 16, 8, 15, 10, 3, 9, 2
E1	17, 8, 9, 2, 5, 11, 4, 10, 3, 16, 15, 12, 20, 7, 6, 18	N5	(Same as N4)
E2	(Same as E1)	N6	(Same as N4)
E8	(Same as E1)	O4	12, 20, 7, 6, 11, 4, 16, 8, 15, 9, 2, 10, 3
E9	(Same as E1)	O5	(Same as O4)
E10	(Same as E1)	O6	(Same as O4)
F1	17, 16, 9, 2, 10, 3, 18, 8, 15, 5, 12, 7, 6, 20	O7	(Same as O4)
F2	(Same as F1)	P4	18, 12, 20, 7, 6, 11, 4, 16, 8, 15, 5, 17, 9, 2, 10, 3
F9	(Same as F1)	P5	(Same as P4)
F10	(Same as F1)	P6	(Same as P4)
G1	9, 2, 5, 11, 4, 10, 3	P6	(Same as P4)
H1	19, 9, 2, 5, 11, 4, 10, 3	Q5	6, 5, 18, 12, 7, 11, 4, 16, 17, 8, 15, 9, 2, 10, 3
H10	(Same as H1)	Q6	(Same as Q5)
I2	10, 3, 5, 11, 4, 9, 2	R6	7, 6, 5, 18, 12, 20, 11, 4, 16, 8, 17, 15, 9, 2, 10, 3
J2	19, 10, 3, 5, 11, 4, 9, 2	S7	7, 6, 17, 16, 9, 2, 18, 8, 15, 5, 12, 10, 3, 11, 4
K1	19, 5, 7, 6, 17, 16, 10, 3, 9, 2, 18, 8, 15, 12, 11, 4, 20		

8.3 Analog Torque Board

This board controls the torque generated in the two reel motors. A functional description, a Block Diagram and Schematic are included in Section 3 of this manual. Periodic adjustments are described in Section 7.

The outputs of the Analog Torque Board go to the Power Supply Board where the Motor Driver circuits are located. Information on the Power Supply Board may be found in Section 6. The troubleshooting aids for this board are divided into (1) a Quick Reference Chart, (2) a Voltage Chart, and (3) a Loss of Function Chart.

QUICK REFERENCE CHART

PROBLEM	POSSIBLE CURE
Tape does not move in PLAY mode.	Check and/or replace IC 13, IC 14.
Reel motors do not idle correctly. No takeup tension (tape spills). Idling speed much too high in either direction.	Check and/or replace supply reel-IC 4, IC 5. Takeup reel-IC 10, IC 11.
PLAY TENSION WRONG. Tape spills in PLAY mode. No supply reel tension in PLAY mode.	Check and/or replace IC 3, IC 6, IC 7. Also check tape speed signal from Phase Locked Loop Board.
FWD mode does not work, or FWD speed is very slow.	Check and/or replace IC 18, IC 19.
RWD mode does not work, or RWD speed is very slow.	Check and/or replace IC 18, IC 19.
Tape tensions do not vary with mode change.	Check tape velocity integrator output from Phase Locked Board to Analog Board at 15 ips. It should read approx. 3.3v DC.

8

LOSS OF FUNCTION CHART

The following chart is arranged with the most significant functions at the left and the least significant functions on the right. If you observe more than one function to be missing (or always "ON"), investigate first the function listed to the left.

Operate the machine in all modes and match the malfunctions to the chart. Check or replace the components listed in that section of the chart.

HINT:
The two torque motor systems have many identical components. Thus components that are suspect can be changed from side to side to help

in locating the trouble. It is best NOT to change trim pot adjustments until you have substituted known good components in the affected circuit.

NOTE:

1. Trim pots R12 & R36 are used to set the OFF-SET NULL to minimum voltage. (Never more than $\pm 0.3v$ DC).

Trim post R18 & R111 are used to set the IDLE adjustment. Tape creep is a sign of misadjustment.

For adjustment procedure see the maintenance section of this manual. This adjustment must be correct before proceeding to other columns of this chart.

2. Soft EDIT is checked with tape loaded on the machine in STOP mode. Force the Supply reel and the Takeup reel in the reverse direction (opposite to their torque). Note that the motors do not fight your efforts, but merely wind up the slack tape.

3. A signal voltage proportional to the speed of the capstan is received from the Phase Locked Loop Board. This signal is used as the divisor in the computation of the

Torque. If this signal is missing, the computation is invalid.

4. All components are located on the Analog Torque Board except those identified by reference to Note 4.

The Motor Driver Amplifiers are located on the Power Supply Board. Refer to Section 6.

LOSS OF FUNCTION CHART

	All Commands	Fast Modes	MVC	Auto Locate	Stop (idle)	Soft Edit (Note 2)	Play Accel. Command	Play Tension Problems	Torque Limit Function	Capstan Problems (Note 3)
SUPPLY MOTOR	Power Supply & Motor Drive board Note 4 IC 28	IC 15 IC 16 IC 18 IC 19 IC 28			IC 4 IC 5 IC 15 IC 16 Note 1 R12 R18			IC 1 IC 2 IC 3 IC 15 IC 16 Note 1 R8		
BOTH MOTORS	+15v -15 +34v	+15v -15 IC 20 IC 21	IC 18 IC 19	IC 13 IC 14 IC 16 IC 17	IC 10 IC 11 IC 24 IC 25 Note 1 R36 R111	IC 13 IC 14 IC 29 Q2	IC 22 IC 23	IC 6 IC 13 IC 14	Q1	PLL bd. IC 9 IC 10 Q2 Note 4 IC 6
TAKEUP MOTOR	Power Supply & motor drive board Note 4 IC 26 IC 27	IC 18 IC 19 IC 24 IC 25 IC 26 IC 27						IC 7 IC 8 IC 9 IC 12 IC 24 IC 25 Note 1 R41		

8.4 Power Supply Motor Driver Board

This board contains the drivers for the Supply Reel Motor, the Takeup Reel Motor, and the regulator circuit which supplies power for the lamps, the relays, and the capstan motor.

The motor drivers are constant current amplifiers

which maintain a fixed current through the motor winding, regardless of the winding resistance or the speed of the motor. The mode command signals fed to the non-inverting input of the op-amp control the amount of current to be fed to the motor.

Since the purpose of the circuit is to deliver a constant current to the motor winding, the voltage

present at the negative end of the winding (and at the collectors of Q1, 3, 9, 10) will vary widely. Other voltages vary only slightly in a circuit which is working normally:

Q1, Q3 — Base	≈1.7v DC
Emitter	≈ .7v DC
Q9, Q10 — Base	≈ .7v DC
Emitter	≈ .1v DC

Voltages at the collectors of the above transistors will vary widely.

IC 1, IC 2 — Set inputs to +1.5v DC (read at input to card)

Pin 3 ≈ +	.1v DC
Pin 6 ≈ +1.2v	DC

LAMP, RELAY, AND CAPSTAN MOTOR SUPPLY

The three transistors in this section provide a

regulated output for the above circuits.

Q5 is the Series Regulator.	Collector ≈ 35v	DC
	Base	≈ 24v DC
	Emitter	≈ 23.4v DC

Q7 and Q8 are Shunt type current limiters. These transistors are turned OFF unless there is excess current.

8.5 Phase Locked Loop Board.

This board controls the capstan motor. Therefore, any problems with the tape speed in play or record modes are likely to be located on this board.

We have divided the troubleshooting information on this circuit into (1) a Quick Reference chart, and (2) a chart of the Wave Forms found on the board. If the Quick Reference chart does not solve your problem, it will be necessary to troubleshoot this circuit with an oscilloscope, using the Wave Form chart.

QUICK REFERENCE CHART

POSSIBLE CURE

If the capstan motor continues to run in STOP mode.

Replace IC 13.

8

If the capstan motor runs away when in PLAY mode.

- A. Check for broken wires on Capstan Tach photocells.
- B. Replace IC 1 on TACH Board.
- C. Check tach connection to Phase Locked Loop Board.

If the capstan motor has a very sluggish start-up.

Replace IC 15, it may be oscillating.

If the capstan motor works normally in Fixed Reference mode, but will not work in Variable mode.

Check and/or replace IC 4, IC 0.

If the capstan motor works normally in Variable mode but will not work in Fixed Reference mode.

Check and/or replace IC 1, IC 2, IC 3.

If the capstan motor works properly in High Speed but not in Low Speed.

Check and/or replace IC 6.

If the capstan motor does not run.

Check and/or replace IC nos. 7, 8, 11, 12, 13, 14 and Q3, Q4.

If the capstan motor runs with an uneven or jerky motion.

Adjust the Phase Locked Loop gain control.

If the capstan motor does not operate in VAR reference position.

Check and/or replace IC 16 (switching ckt.), IC 5 (VCO), and IC 4 (DC buffer).

If the capstan motor does not follow an External signal when in EXT reference position.

Check and/or replace IC 16 (switching ckt.), and IC 18 (retriggerable one-shot).

This circuit is a closed loop amplifier, and each signal wave form and voltage depends on the previous signal — all the way around the circle.



Before starting the wave form analysis, check the supply voltages:

Therefore it is difficult to isolate the point where the trouble starts. Your oscilloscope MUST be capable of measuring the duration and the amplitude of the pulses with reasonable accuracy.

± 5v DC across CR7, CR8
+22v DC at P47 Pin 9, 10
±15v DC at P45 Pin 1, 2, to gnd.

WAVE FORM CHART

Test conditions: Fixed reference, 15 ips, PLAY mode.

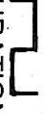
TEST POINT	PULSE DESCRIPTION			PEAK TO-PEAK VOLTAGE
				
IC 1, Pin 6	Triangular	Triangular	10 μ Sec.	4
IC 2, Pin 6	5 μ Sec.	5 μ Sec.	10 μ Sec.	11.5
TP 2	50 μ Sec.	50 μ Sec.	100 μ Sec.	4
IC 3, Pin 12	50 μ Sec.	50 μ Sec.	100 μ Sec.	4
IC 6, Pin 1	10 μ Sec.	40 μ Sec.	50 μ Sec.	4
IC 6, Pin 6	50 μ Sec.	50 μ Sec.	100 μ Sec.	4
IC 6, Pin 7	100 μ Sec.	100 μ Sec.	200 μ Sec.	4
IC 15, Pin 3	20 μ Sec.	80 μ Sec.	100 μ Sec.	4
TP 1	20 μ Sec.	80 μ Sec.	100 μ Sec.	6
IC 8, Pin 8	*.2 μ Sec.	99.8 μ Sec.	100 μ Sec.	4
IC 8, Pin 9	*.2 μ Sec.	99.8 μ Sec.	100 μ Sec.	4
TP 3 (Adj. R42 for)	30 μ Sec.	70 μ Sec.	100 μ Sec.	4

* These pulses will be visible ONLY on a high speed scope (30mHz or better).

There are presently two versions of the low speed option to the JH-110B. One version uses jumpers on the Phase Locked Loop Board to lower the tape speed. These jumpers select an additional flip-flop to divide the reference frequencies by two. The other version uses a ¼ inch capstan shaft to lower the tape speed.

Refer to notes 9, 10, and 13 on the Phase Locked Loop Board schematic for jumper placement.

8.6 Audio Electronics

Each channel has a mother board and three plug-in boards which are identical and interchangeable. The schematics for these boards have both DC and SIGNAL voltage notations at important points.

The first step in isolating trouble within a channel should be to substitute plug-in boards from a working channel or from your Spare Parts Kit. This should verify your analysis of where the trouble is located.

Standard progressive isolation procedures, using

the information available on the schematics, should easily locate the defective component.

NOTE:

The P1086E transistors used on all three of these boards are depletion model "p" channel Field Effect Transistors. They are used as SWITCHES and take the place of the many small relays used in other professional machines.

The Field Effect Transistors used on the Bias Card are carefully selected for an exact pinch-off voltage. Punch in/punch out performance of the machine is directly affected by the pinch-off voltage of these FETs. If replacements are needed, secure them from MCI Customer Service.

These FETs are turned OFF by a +18v DC control voltage. They turn ON when the control voltage goes to 0v.

The Audio Block Diagrams (Figures 5-2 and 5-3) will prove very helpful. They show the location of each function and help to tie all of the schematics together.

REPRO CARD

PROBLEM	POSSIBLE CAUSE
1. Input mode only	Q13 and support components
2. Cue mode only	Q12 and support components
3. Repro mode only	Q11 and support components
4. Output section	IC6 and support components
5. Meters pin momentarily when machine is turned ON after being off for more than 30 seconds.	Q14 and support components C44, C43 or C11 leaky, R15 open, IC2 high offset, front end high offset.
6. No response below 2 KHz	IC4 and support components
7. No audio (other than output stage)	IC5 and support components
8. Asymmetrical clipping	Same as 5
9. No low frequency adjust or control interaction	Q4, Q5, Q6, Q7, and support components
10. No high frequency adjust or control interaction	Q8, Q9, support components, FET control lines
11. Front end not functioning or high offset.	Q3A, Q3B, IC1, IC2, IC3 and support components
12. Card unusually noisy	Q3A, Q3B, IC1, IC2, IC3, IC4, or FETS
13. NAB/IEC low end switching not functional	Q7, S1, or R24
14. NAB/IEC switching, not tracking	Not aligned correctly. R34, R33, R35, R37 out of tolerance, wrong heads installed.
15. No high end response	Q8, Q9, Q10, and support components, FET controls, S1

RECORD CARD

PROBLEM	POSSIBLE CAUSE
1. No output	IC4, IC3, IC1, and support components
2. No high end	IC2 and support components, Q1, Q2, Q3 and control lines, R43
3. Response not flat on one speed	Differentiator FET summing resistors and capacitors, FETs, FET feedback components
4. No low end	R41
5. Linearity not functional	R43, CR1, CR2
6. Response not flat at all speeds	Repro not aligned correctly, wrong overbias
7. NAB/IEC switching not tracking	Repro not aligned correctly, wrong overbias, wrong heads installed
8. NAB/IEC low end switching not functional	Q4 and support components, C25 (NAB), C25 and C4 (IEC)
9. Too much low end at 30 ips (AES EQ) when in NAB, but correct when switched to IEC	CR3 open, Q4 not conducting.

8

8.7 RTZ III

Refer to Schematics 25D609, 25E611, and 25E625.

Instruments needed for testing include:

WARNING
Any damage to P.C. Boards caused by unauthorized repair will void MCI Warranty. Contact your MCI dealer for repair, if you are uncertain of the problems.

- A. Multimeter with 3% full scale accuracy
- B. An oscilloscope with a minimum 10 MHz bandwidth.

TROUBLESHOOTING GUIDE

TROUBLESHOOTING TABLE

SYMPTOM	CAUSE
No Display	Test Power Supply Input checkout ribbon cable from Processor Board to Display Board.
Complete Non-Operation	IC12 (8085A Microprocessor) — If the test points differ from normal value as outlined on the following page, replace the IC's associated with that line. A many functioned failure should be cause for replacing the microprocessor.
Bad Display Digit(s)	IC11 (EPROM) defective on Processor Board. Check associated MAN3620 and/or associated 7447.
Tape Position Display Defective	Check roller guide pulses input to IC9. IC9 defective, clamping diodes CR5, CR6 defective. All on Processor Board.
Tape Position Displays Time In One Direction	IC15 defective on Processor Board. Check clamp diodes on Processor Board.
Cannot Enter Commands From Keyboard	Keyboard switch(s) defective. 74C923 (IC2) on Processor Board defective.
No Velocity Indication	Check Capstan pulses. IC8 defective. Clamp Diodes CR3, CR4 defective. Check 19.2 KHz reference @ IC6, PIN 3. IC6 defective.
No Variable Speed Control	Check VCO in Display Board (IC4 and IC5). Defective cable connection IC7 on Display Board defective. Check +15, -15 from Display Board.
Mode Control Inoperative	IC6 on Display Board defective. Q1, Q2 on Display Board defective. LED defective. Q1 defective on Processor Board.
These possible deficiencies relate to the Processor Plug On Board P/N 2500C0625-00 for the RTZIII/M.	
BAND/L-OUT Button Inoperative	Q2 2N3904 defective
XPD Button Inoperative	Q3 2N30904 defective
XPD, BND/LEADOUT Buttons Inoperative	IC2 on Processor Board bad switch

XPD Storage Inoperative IC16 on Plug On Board
 BND/LEADOUT Storage IC16 on Plug On Board
 Inoperative

CRITICAL CIRCUIT ELEMENTS, VOLTAGES AND WAVEFORMS

Turn power on. The RTZ III should display 0000 and be in normal operational condition. (All measurements are to chassis ground.)

PROCESSOR BOARD (2500E0611-00)

IC11 Pin 19	+12 VDC Regulated
IC11 Pin 21	- 5 VDC Regulated
IC11 Pin 24	+ 5 VDC Regulated
Q3 Emitter & Collector	+12 VDC Regulated
Q4 Emitter & Collector	+ 5 VDC Regulated

NOTE:

Q3 and Q4 operate cool. If either is hot to the touch, replace.

IC12 (8085A Microprocessor) Measurements are to ground.

PIN 1	X1	Approximately 6 MHz SINEWAVE
PIN 2	X2	
PIN 3	RESET	Logic 0 0.2v
PIN 4	SOD	NO MEANING connected to J2
PIN 5	SID	NO MEANING connected to J2
PIN 6	TRAP	ZERO (GND)
PIN 7	RST 7.5	Logic 0 0.2v
PIN 8	RST 6.5	Logic 0 0.2v
PIN 9	RST 5.5	Logic 0 0.2v
PIN 10	INTR	ZERO (GND)
PIN 11	INTA	Logic 1 3.0v
PIN 12 to 19		irregular digital pulses
PIN 21-25		SQUAREWAVE 3 MHz, 3V
PIN 25		
PIN 26 to 28		irregular pulses
PIN 30,31,32,34		to be checked if Pin 3 is held @ 0.2V or 3V
PIN 36	RESET IN	continuously—check out circuit elements connected to Pin 36.
PIN 37	CLK	SQUAREWAVE 3 MHz@ 3V
PIN 39	HOLD	ZERO (GND)

IC6 contains the live memory (256 bytes of RAM) used by the program. IC6 is associated with the display control, the D/A (IC4) speed control and a timer (TVI).

IC8 and IC9 are request latches. Roller guide and capstan pulses are fed into them. IC8 and IC9 are cleared by IC15 (8255A). EPROM (IC11) controls this sequence.

SECTION 9

SPARE PARTS KITS

MCI offers four spare parts kits for the JH-110B to support your particular level of maintenance. This section lists the contents of each kit. These kits are available through your dealer or through MCI's Customer Service Department. When ordering a kit, specify the model and all options included.

Spare parts kit number one is a collection of components that are most often used in printed circuit board level repair. Most of these components are difficult to obtain locally. Common components that are easily obtainable are not included in this kit.

Spares kit number two contains transport lamps, switches, and relays which are all high use items.

Spares kit number three consists of replacement circuit boards and assemblies. This kit is necessary for facilities performing board swapping maintenance or responding to emergency repair situations.

Spares kit number four contains replacement circuit boards and assemblies as does kit number three. This kit is intended to support more extensive maintenance activities.

SPARE PARTS LIST NUMBER 1
Active Spares Kit

Ordering Number: JH110B-S-KIT-AA

Quantity	Description	Quantity	Description
6	2003P Op Amp	1	74C912 Display Control
6	P1086RR FET	1	7400 Quad 2-NAND
2	LM394H Transistor	1	7402 Quad 2-NOR
2	AD532J Multi-divider	1	7408 Quad 2-AND
3	SP-7000-0127-01 Sel. Transistor	1	7404 Hex Inverter
2	2N2270 Transistor	1	7410 Trip 3-NAND
2	2N5783 Transistor	1	7420 Dual 4-NAND
2	2N3053 Transistor	1	7432 Quad 2-OR
1	2N4249 Transistor	1	74C00N Quad 2-NAND
4	2N3055-H Transistor	4	741CP Op Amp
1	LM309KC-5 5v Regulator	1	75454 Driver IC
1	LM340KC-18 18v Regulator	1	7426 Quad 2-NAND HV
1	LM320KC-18 -18v Regulator	1	74122 One Shot
1	LM340KC-15 15v Regulator	1	7427 Trip 3-NOR
1	LM320KC-15 -15v Regulator	1	7493 Counter
4	1N4004J4 Diode	1	74121 One Shot
1	1N5252B-24V 24v Zener	1	74123 One Shot
1	1N5231B-5.1V 5.1v Zener	1	7495 4-bit Parallel
2	1N34 Diode	1	7490 Decade Counter
2	1N914 Diode	2	TL081CP Op Amp
1	1N5241-11V 11v Zener	1	NE566 Function Generator
2	1N5245B-15V 15v Zener	2	0.180 OHM 10%-2Ww Resistor
1	ICTE-5-5V Surgister	1	TIL143 Tape Sensor
1	1N5243-13V 13v Zener	1	2:5-9:0PF Trim Cap
1	7447BCD 7 Segment Decoder	1	1N5246-16V 16v Zener
1	0.15-OHM 10%-3Ww Resistor	1	PCA2700-0051 Reprp Extender
2	IH5011 Analog Switch	1	PCA2700-0052 Record Extender
1	OPB-125 Photo Cell	1	PCA2700-0053 Bias Extender
1	4114R-001-104 100k Resistor DIP	2	LM350K 22v Regulator
1	4114R-001-181 180k Resistor DIP	2	MDL--4.0A-250V Fuse
2	2N3906 Transistor	2	MDL--2.0A-250V Fuse
1	78M12CP 12v Regulator	6	2003M Op Amp
1	LM324 Quad Op Amp	1	74LS74 Dual Flip-Flop
1	MJE-3055 Transistor	1	LF347N Quad Bifet Op Amp
1	MAN-3620 LED Display	2	

9

SPARE PARTS LIST NUMBER 2

Switch Spares Kit

Ordering Numbers: JH110B-S-KIT-AB (Non-BX)
 JH110B-S-KIT-AT (JH-110BX)

Quantity	Description	Quantity	Description
1	HC4E-24VDC Relay	1 ¹	SP-7000-2305-14 Switch
1 ¹	K4E24V-9 Relay	2	MST-105D Switch
8	SP-7000-0550-00 Lamp	1	SP-7100-2308-07 Switch
4	01-903 Lamp	1 ¹	SP-7100-2308-06 Switch
1	01-121 Switch	1	JBT-2223L Switch
1	01-151 Switch	2 ¹	SP-7000-2305-12 Switch
2	L41-2-0-000A Red LED	1 ²	SP-7100-2308-62 Switch
2	L41-1-0-000A Amber LED		
2 ¹	L41-4-0-000A Green LED		

¹ Included in Kit AB only

² Included in Kit AT only

SPARE PARTS LIST NUMBER 3

PCA Spares Kit

Ordering Numbers:

JH110B-S-KIT-AC (Standard speed two track)
 JH110B-S-KIT-AD (Low speed option two track)
 JH110B-S-KIT-AE (Standard speed four track)
 JH110B-S-KIT-AF (Low speed option four track)
 JH110B-S-KIT-AG (JH-110BC)
 JH110B-S-KIT-AH (JH-110M)
 JH110B-S-KIT-AU (JH-110BX)

Quantity	Description
1	PCA2500-0027-00 Control Logic Board
1	PCA2500-0600-00 Phase Locked Loop Board
1	PCA2600-0001-23 Analog Torque Board
1	PCA2500-0042-00 Solenoid Driver Board
1	PCA2700-0913-00 Reproduce Board
1	PCA2700-0916-00 I/O Board
1	PCA2700-0914-00 Record Board
1	PCA2700-0055-01 Bias Board
1	PCA2700-0005-01 Strip Board with Oscillator
1	MCA2500-0194-40 Power Supply Chimney
1	52-5488 VU Meter
1	AS-6000-0237-21 Pinch Roller
1	SP-7000-0196-01 DC Tach Generator
1 ¹	PCA2700-0915-00 Front Panel EQ Board
1 ¹	PCA2700-0927-00 Lo Freq EQ Pot Assy
1 ¹	PCA2700-0928-00 Hi Freq. EQ Pot Assy
1	PCA2500-0416-00 Lamp Driver/Interface Board
1 ²	PCA2700-0048-00 Strip Board without Oscillator
1 ³	SP-7000-0193-00 Transformer

9 Contents of kit varies depending upon particular model and options. Be sure to specify model number and all options installed when ordering kits.

¹ Included in Kit AH only

² Included in Kits AE, AF, and AH only

³ Included in Kit AG only

SPARE PARTS KIT NUMBER 4

Optional parts for heavy support

Ordering numbers:

JH110B-S-KIT-AI (Standard speed 1/4 inch)
 JH110B-S-KIT-AJ (Low speed option 1/4 inch)
 JH110B-S-KIT-AK (Standard speed 1/2 inch)
 JH110B-S-KIT-AL (Low speed option 1/2 inch)
 JH110B-S-KIT-AM (JH-110BC and BX)
 JH110B-S-KIT-AN (JH-110M standard speed 1/4 inch)
 JH110B-S-KIT-AO (JH-110M low speed option 1/4 inch)
 JH110B-S-KIT-AP (JH-110M standard speed 1/2 inch)
 JH110B-S-KIT-AQ (JH-110M low speed option 1/2 inch)
 JH110B-S-KIT-AR (1 inch)

Quantity	Description
1	PCA2500-0609 RTZ III Display Board
1	PCA2500-0639 RTZ III Processor Board
1	ASA2500-0129 Capstan Motor Assembly
1	AS-7100-1002 Reel Motor Assembly
2	42C24DCAU Lifter or Brake Solenoid
1	MC-2500-0104 Pinch Roller Solenoid
1	23X30B-4-QZ Reference Switch
1	14X30B-2-QZ Speed Switch
1 ¹	14X30B-3-QZ Speed Switch
1 ²	14X30B-3-QZ Speed Switch
1	3540S-1-103 Vari Speed Potentiometer
1 ³	MCA2600-0316 1/4" Roller Guide Tach
1 ⁴	MCA2600-0317 1/2" Roller Guide Tach
1 ⁵	MC-2600-0607 1" Roller Guide Tach
2	B527-1 Black Knobs
1	Molex Connector Assortment
1	D45121-1 Dash Pot
1 ⁶	PCA2500-0625 Processor Plug-on Board

Contents of kit varies with ordering number. Be sure to specify model number and all options installed when ordering kits.

- ¹ Included in Kit AM only
- ² Included in all kits except AM
- ³ Included in Kits AI, AJ, AM, AN, and AO only
- ⁴ Included in Kits AK, AL, AP, and AQ only
- ⁵ Included in Kit AR only
- ⁶ Included in Kits AN, AO, AP and AQ only



SECTION 10

UPGRADING KITS

10.1 Possible Configurations

MCI builds six systems in the JH-110 Series: the JH-110B, JH-110B-14, JH-110BC, JH-110BX, JH-110C-8, and the JH-110M. Most of these systems are available in various track configurations and may be converted or upgraded to a different number of tracks and tape widths. With the applicable upgrade kit it is possible to use your JH-110 transport as either a mono recorder or a stereo recorder by simply changing head bridges. Upgrade kits contain a head bridge, roller guides if tape width changes, additional audio electronics if tracks are added, and head cables and power supply cables if required. Consult the JH-110 Series Product Configuration Sheets for kit contents, ordering numbers, and further information.

Any JH-110B or JH-110B-14 can be configured in the following ways:

- * mono 1/4" format
- * two track 1/4" format
- * DIN stereo 1/4" format
- * 1/4 track stereo 1/4" format
- * two track 1/2" format
- * four track 1/2" format

Any JH-110BC can be configured in the following ways:

- * DIN stereo 1/4" format
- * two track 1/2" format

Any JH-110BX can be configured in the following ways:

- * Mono 1/4" format
- * two track 1/4" format
- * DIN stereo 1/4" format
- * 1/4 track stereo 1/4" format

Any JH-110C can be configured in the following ways:

- * four track 1/2" format
- * eight track 1" format

Any JH-110M can be configured in the following ways:

- * mono 1/4" format
- * two track 1/4" format
- * DIN stereo 1/4" format
- * 1/4 track stereo 1/4" format
- * two track 1/2" format

10.2 Upgrading A Mono Machine To A Stereo Machine

This upgrade involves adding one channel of electronics, changing the head cable, and swapping the head bridge assembly. If the change is from a mono machine to a 1/2 inch format stereo machine, the roller guides must be swapped also. After performing this modification, your tape recorder can be used as either a mono or stereo recorder by simply changing the head bridge assembly (and the roller guides if applicable). The following parts are required:

- * Repro Board
- * Record Board
- * Bias Board
- * Audio Mother Board with front panel
- * two track head bridge assembly
- * stereo head cable
- * 1/2" roller guides if 1/2" tape format is desired

Step 1. Turn power off.

- Step 2. Install the new audio electronics.
- Remove the filler panel from the electronics drawer.
 - Plug the new Audio Mother Board into the Strip Board.
 - Secure the Mother Board in the drawer with four #4-40 screws through the board and two #6-32 screws through the front panel.
 - Plug the audio circuit boards into the Mother Board.

- Step 3. Remove the RTZ III processor assembly.
- Disconnect the five cables. Note their positions for reassembly.
 - Pull the Processor Board from its shield assembly.
 - Remove the processor board shield by removing the four #6-32x $\frac{1}{4}$ " screws.

- Step 4. Install the stereo head cable.
- Remove the two #10-32x $\frac{1}{2}$ " screws holding the cable and shield and remove the shield.
 - Unplug the head cable from the back of the audio drawer.
 - Install the stereo head cable with the two #10-32x $\frac{1}{2}$ " screws.
 - Plug the head cables into the back of the audio drawer.

- Step 5. Replace the RTZ III processor assembly.
- Replace the processor shield on its stand-offs and tighten the four #6-32x $\frac{1}{4}$ " screws.
 - Reconnect the Processor Board to the shield.
 - Plug the cables back into the board.

- Step 6. Remove the head bridge assembly by loosening the two hex socket screws and replace with the new head bridge assembly.

10.3 Upgrading A Two Track Machine To A Four Track Machine

These kits are for the JH-110B and JH-110B-14 tape recorders only. The JH-110BC, JH-110BX, and JH-110M cannot be upgraded to four track machines.

After performing this upgrade, you can use your JH-110B as either a two track or four track recorder by simply swapping the head bridge and roller guides.

In most cases the tape path width changes from $\frac{1}{4}$ inch to $\frac{1}{2}$ inch. These upgrade kits contain the following:

- * Drawer assembly containing two complete channels of audio electronics
- * four track head bridge assembly
- * $\frac{1}{2}$ inch roller guides
- * power supply cable
- * four channel head cable

Step 1. Turn power off.

- Step 2. Install the new audio drawer assembly.
- Remove the filler panel from the cabinet by removing the four #10-32x $\frac{1}{2}$ " socket head screws.
 - Slide the drawer assembly into the cabinet and replace the four #10-32x $\frac{1}{2}$ " socket head screws.

- Step 3. Remove the RTZ III processor assembly.
- Disconnect the five cables, note their correct positions.
 - Pull the Processor Board from its shield assembly.
 - Remove the processor shield by removing the four #6-32x $\frac{1}{4}$ " screws.

- Step 4. Install the four track head cable.
- Remove the two #10-32x $\frac{1}{2}$ " screws holding the cable and shield. Remove the cable.
 - Unplug the head cables from the back of the audio drawer.
 - Install the four track head cable with the two #10-32x $\frac{1}{2}$ " screws.
 - Plug the head cables into the back of the audio drawers.

- Step 5. Replace the RTZ III processor assembly.
- Replace the processor shield on its stand-offs and tighten the four #6-32x $\frac{1}{4}$ " screws.
 - Reconnect the Processor Board to its shield.
 - Plug the cables back into the board.
- Step 6. Install the new power supply cable.

Step 7. Remove the head bridge assembly by loosening the two hex socket head screws and replace it with the new head bridge assembly.

Step 8. Remove the 1/4 inch roller guides and replace them with the 1/2 inch roller guides.

10.4 Installing An Additional Playback Head

Many users find it useful to have the capability of monitoring 1/4 track stereo tapes on their JH-110B two track transport. The additional 1/4 track stereo format repro head mounts in the head bridge to the left of the erase head. Refer to the pictorial in Section 3 showing the mounting of the heads in the head bridge.

This kit contains the following:

- * drawer assembly containing two channels of playback only electronics
- * 1/4 track stereo format head assembly with mounting block
- * four channel head cable
- * power supply cable

Step 1. Perform Steps 1 through 6 of Section 10.3.

Step 2. Install the new head assembly.

- a. Remove the head bridge assembly by loosening the two hex socket head screws.
- b. Remove the two #4-40x1/2" screws holding the Amp connector in place.
- c. Place the new head assembly in the 'optional preview head' location as shown in the Head Assembly Pictorial in Section 3. Secure the head assembly with the #8-32x1/2" Allen flat head screw.
- d. Insert the head wire pins into the Amp connector.
 - Left channel orange into pin V
 - Left channel green into pin W
 - Right channel orange into pin X
 - Right channel green into pin Y
- e. Replace the Amp connector. Tighten the two screws until they are just snug, then back the screws out by one half turn. You must allow free play movement for the Amp connector.
- f. Replace the head bridge assembly and tighten the mounting screws.

Step 3. Perform the head alignment procedure as described in Section 7.